

SECOND EDITION

# BIM Handbook

A GUIDE TO BUILDING INFORMATION MODELING  
FOR OWNERS, MANAGERS, DESIGNERS, ENGINEERS, AND CONTRACTORS



CHUCK EASTMAN • PAUL TEICHOLZ • RAFAEL SACKS • KATHLEEN LISTON



# BIM Handbook

---

A Guide to Building Information  
Modeling for Owners, Managers,  
Designers, Engineers, and Contractors

Second Edition

Chuck Eastman  
Paul Teicholz  
Rafael Sacks  
Kathleen Liston



WILEY

John Wiley & Sons, Inc.

This book is printed on acid-free paper. ∞

Copyright © 2011 by John Wiley & Sons, Inc.. All rights reserved  
Published by John Wiley & Sons, Inc., Hoboken, New Jersey  
Published simultaneously in Canada

No part of this publication may be reproduced, stored in a retrieval system, or transmitted in any form or by any means, electronic, mechanical, photocopying, recording, scanning, or otherwise, except as permitted under Section 107 or 108 of the 1976 United States Copyright Act, without either the prior written permission of the Publisher, or authorization through payment of the appropriate per-copy fee to the Copyright Clearance Center, 222 Rosewood Drive, Danvers, MA 01923, (978) 750-8400, fax (978) 646-8600, or on the web at [www.copyright.com](http://www.copyright.com). Requests to the Publisher for permission should be addressed to the Permissions Department, John Wiley & Sons, Inc., 111 River Street, Hoboken, NJ 07030, (201) 748-6011, fax (201) 748-6008, or online at [www.wiley.com/go/permissions](http://www.wiley.com/go/permissions).

**Limit of Liability/Disclaimer of Warranty:** While the publisher and the author have used their best efforts in preparing this book, they make no representations or warranties with respect to the accuracy or completeness of the contents of this book and specifically disclaim any implied warranties of merchantability or fitness for a particular purpose. No warranty may be created or extended by sales representatives or written sales materials. The advice and strategies contained herein may not be suitable for your situation. You should consult with a professional where appropriate. Neither the publisher nor the author shall be liable for any loss of profit or any other commercial damages, including but not limited to special, incidental, consequential, or other damages.

For general information about our other products and services, please contact our Customer Care Department within the United States at (800) 762-2974, outside the United States at (317) 572-5993 or fax (317) 572-4002.

Wiley also publishes its books in a variety of electronic formats. Some content that appears in print may not be available in electronic books. For more information about Wiley products, visit our web site at [www.wiley.com](http://www.wiley.com).

***Library of Congress Cataloging-in-Publication Data:***

BIM handbook : a guide to building information modeling for owners, managers, designers, engineers and contractors / Chuck Eastman . . . [et al.]. — 2nd ed.

p. cm.

Includes bibliographical references and index.

ISBN 978-0-470-54137-1 (hardback); 978-0-470-95134-7 (ebk); 978-0-470-95153-8 (ebk); 978-1-118-02167-5 (ebk); 978-1-118-02168-2 (ebk); 978-1-118-02169-9 (ebk)

1. Building—Computer simulation—Handbooks, manuals, etc. 2. Building management—Data processing—Handbooks, manuals, etc. 3. Communication in the building trades—Handbooks, manuals, etc. 4. Architectural practice—Handbooks, manuals, etc. 5. Architects and builders—Handbooks, manuals, etc. 6. Construction industry—Information resources management—Handbooks, manuals, etc. I. Eastman, Charles M.

TH437.B53 2011

690.0285—dc22

2010045229

Printed in the United States of America

SECOND EDITION

10 9 8 7 6 5 4 3 2 1

# Contents

---

Foreword	vii	
Preface	xi	
CHAPTER 1	BIM Handbook Introduction	1
1.0	Executive Summary	1
1.1	Introduction	2
1.2	The Current AEC Business Model	2
1.3	Documented Inefficiencies of Traditional Approaches	10
1.4	BIM: New Tools and New Processes	15
1.5	What Is Not BIM Technology?	19
1.6	What Are the Benefits of BIM? What Problems Does It Address?	19
1.7	What Challenges Can Be Expected?	26
1.8	Future of Designing and Building with BIM (Chapter 8)	29
1.9	Case Studies (Chapter 9)	29
	Chapter 1 Discussion Questions	29
CHAPTER 2	BIM Tools and Parametric Modeling	31
2.0	Executive Summary	31
2.1	The Evolution to Object-Based Parametric Modeling	32
2.2	Parametric Modeling of Buildings	45
2.3	Beyond Parametric Shapes	57
2.4	BIM Environments, Platforms, and Tools	70
2.5	Overview of the Major BIM Design Platforms	71
2.6	BIM Platforms	77
2.7	Lightweight Modeling Applications	94
2.8	Conclusion	95
	Chapter 2 Discussion Questions	97

CHAPTER 3	Interoperability	99
	3.0 Executive Summary	99
	3.1 Introduction	100
	3.2 Different Kinds of Exchange Formats	105
	3.3 Background of Product Data Models	110
	3.4 Other Efforts Supporting Standardization	129
	3.5 The Evolution from File-Based Exchange to Building Model Repositories	136
	3.6 Summary	148
	Chapter 3 Discussion Questions	148
CHAPTER 4	BIM for Owners and Facility Managers	151
	4.0 Executive Summary	151
	4.1 Introduction: Why Owners Should Care About BIM	152
	4.2 BIM Application Areas for Owners	155
	4.3 BIM Tool Guide for Owners	169
	4.4 An Owner and Facility Manager's Building Model	172
	4.5 Leading the BIM Implementation on a Project	175
	4.6 Barriers to Implementing BIM: Risks and Common Myths	185
	4.7 Guidelines and Issues for Owners to Consider When Adopting BIM	189
	Chapter 4 Discussion Questions	191
CHAPTER 5	BIM for Architects and Engineers	193
	5.0 Executive Summary	193
	5.1 Introduction	194
	5.2 Scope of Design Services	197
	5.3 BIM Use in Design Processes	203
	5.4 Building Object Models and Libraries	240
	5.5 Considerations in Adoption for Design Practice	253
	5.6 New and Changed Staffing within Design Firms	258
	Chapter 5 Discussion Questions	260
CHAPTER 6	BIM for Contractors	263
	6.0 Executive Summary	263
	6.1 Introduction	264
	6.2 Types of Construction Firms	265
	6.3 Information Contractors Want from BIM	268

---

6.4	Processes to Develop a Contractor Building Information Model	270
6.5	Reduction of Design Errors Using Clash Detection	272
6.6	Quantity Takeoff and Cost Estimating	275
6.7	Construction Analysis and Planning	281
6.8	Integration with Cost and Schedule Control and Other Management Functions	293
6.9	Use for Offsite Fabrication	295
6.10	Use of BIM Onsite: Verification, Guidance, and Tracking of Construction Activities	296
6.11	Synergies of BIM and Lean Construction	297
6.12	Implications for Contract and Organizational Changes	300
6.13	BIM Implementation	302
	Chapter 6 Discussion Questions	303
<b>CHAPTER 7</b>	<b>BIM for Subcontractors and Fabricators</b>	<b>305</b>
7.0	Executive Summary	305
7.1	Introduction	306
7.2	Types of Subcontractors and Fabricators	308
7.3	The Benefits of a BIM Process for Subcontractor Fabricators	310
7.4	BIM-Enabled Process Change	324
7.5	Generic BIM System Requirements for Fabricators	328
7.6	Major Classes of Fabricators and Their Specific Needs	333
7.7	Adopting BIM in a Fabrication Operation	342
7.8	Conclusions	348
	Chapter 7 Discussion Questions	348
<b>CHAPTER 8</b>	<b>The Future: Building with BIM</b>	<b>351</b>
8.0	Executive Summary	351
8.1	Introduction	353
8.2	The Development of BIM up to 2010	353
8.3	Current Trends	354
8.4	Vision 2015	361
8.5	Drivers of Change and BIM Impacts up to 2020	380
<b>CHAPTER 9</b>	<b>BIM Case Studies</b>	<b>391</b>
9.0	Introduction	391
9.1	Aviva Stadium	397

9.2	Courtyard by Marriott	415
9.3	Sutter Medical Center, Castro Valley	431
9.4	Maryland General Hospital	480
9.5	Crusell Bridge	494
9.6	100 11th Avenue, New York City	514
9.7	One Island East Project, Hong Kong	526
9.8	Helsinki Music Center	539
9.9	Hillwood Commercial Project	557
9.10	United States Coast Guard BIM Implementation	566
	Glossary	585
	Bibliography	591
	Index	611



# Foreword

---

In the seven years since the term “Building Information Modeling” or BIM was first introduced in the AEC industry, it has gone from being a buzzword with a handful of early adopters to the centerpiece of AEC technology, which encompasses all aspects of the design, construction, and operation of a building. Most of the world’s leading architecture, engineering, and construction firms have already left behind their earlier, drawing-based, CAD technologies and are using BIM for nearly all of their projects. The majority of other firms also have their transitions from CAD to BIM well underway. BIM solutions are now the key technology offered by all the established AEC technology vendors that were earlier providing CAD solutions. In addition, the number of new technology providers that are developing add-on solutions to extend the capabilities of the main BIM applications in various ways is growing at an exponential pace. In short, BIM has not only arrived in the AEC industry but has literally taken it over, which is particularly remarkable in an industry that has historically been notoriously resistant to change.

It is important to keep in mind that BIM is not just a technology change, but also a process change. By enabling a building to be represented by intelligent objects that carry detailed information about themselves and also understand their relationship with other objects in the building model, BIM not only changes how building drawings and visualizations are created, but also dramatically alters all of the key processes involved in putting a building together: how the client’s programmatic requirements are captured and used to develop space plans and early-stage concepts; how design alternatives are analyzed for aspects such as energy, structure, spatial configuration, way-finding, cost, constructability, and so on; how multiple team members collaborate on a design, within a single discipline as well as across multiple disciplines; how the building is actually constructed, including the fabrication of different components by sub-contractors; and how, after construction, the building facility is operated and maintained. BIM impacts each of these processes by bringing in more intelligence and greater efficiency. It also goes over and beyond improving existing processes by enabling entirely new capabilities, such as checking a multi-disciplinary model for conflicts prior to construction, automatically checking a

design for satisfaction of building codes, enabling a distributed team to work simultaneously on a project in real time, and constructing a building directly from a model, thereby passing 2D drawings altogether. It is hardly surprising, then, to find that BIM has also become the catalyst for significant process and contractual changes in the AEC industry such as the growing move towards IPD or “Integrated Project Delivery.”

Given how vast BIM is, both as a multi-disciplinary design, analysis, construction, and facilities management technology, as well as the harbinger of dramatic process changes, it would seem almost impossible to distill the essence of it in a book. Yet this is precisely what *The BIM Handbook* has been able to do. It provides an in-depth understanding of the technology and processes behind building information modeling, the business and organizational issues associated with its implementation, and the advantages that the effective use of BIM can provide to all members of a project team, including architects, engineers, contractors and sub-contractors, facility owners and operators, as well as building product suppliers who need to model their products so that they can be incorporated into the building model. The book is targeted towards both practitioners in the industry as well as students and researchers in academia. For practitioners, it provides not just a deeper understanding of BIM but practical information including the software applications that are available, their relative strengths and limitations, costs and needed infrastructure, case studies, and guidance for successful implementation. For students and researchers, it provides extensive information on the theoretical aspects of BIM that will be critical to further study and research in the field.

First published in 2008, *The BIM Handbook* is authored by a team of leading academics and researchers including Chuck Eastman, Paul Teicholz, Rafael Sacks, and Kathleen Liston. It would be difficult to find a team more suited to crafting the ultimate book on BIM. Chuck Eastman, in particular, can be regarded as the world’s leading authority on building modeling, a field he has been working in since the 1970s at universities including UCLA and Carnegie-Mellon. I referred to his papers and books extensively during the course of my own Ph.D. work in building modeling while I was at UC Berkeley. In 1999, he published the book *Building Product Models: Computer Environments Supporting Design and Construction*, which was the first and only book to extensively compile and discuss the concepts, technologies, standards, and projects that had been developed in defining computational data models for supporting varied aspects of building design, engineering, and construction. He continues to lead research in the area of building product models and IT in building construction in his current role as Professor in the Colleges of Architecture and Computing at Georgia Institute of Technology, Atlanta,

and Director of Georgia Tech's Digital Building Laboratory. In addition to his research and teaching work, Chuck is very active in industry associations such as the AISC, NIBS, FIATECH, and AIA TAP, and is a frequent speaker at industry conferences.

Given his credentials and those of his co-authors including Paul Teicholz, who founded the Center for Integrated Facility Engineering (CIFE) at Stanford University and directed that program for 10 years; Rafael Sacks, Associate Professor in Construction Management at the Technion (Israel Institute of Technology); and Kathleen Liston, also from Stanford University and an industry practitioner, it is hardly surprising that *The BIM Handbook* continues to be one of the most comprehensive and authoritative published resources on BIM. This new second edition, coming three years after the publication of the first edition, keeps up with all of the rapid advances in BIM technology and associated processes, including new BIM tools and updates to the existing tools, the growing availability of model servers for BIM-based collaboration, the increasing focus on extending BIM technology all the way through to facilities management, the growing use of BIM to support sustainable design and lean construction, the integration of BIM with technologies such as laser-scanning to capture as-built conditions, and the growing momentum of alternate delivery models such as IPD. The new edition also greatly expands upon the case studies section of the first edition, highlighting several new projects that have pushed the boundaries of BIM use to achieve exceptional results, both in signature architecture as well as more common building designs.

The book is well organized with an executive summary at the beginning of each chapter providing a synopsis of its content and a list of relevant discussion questions at the conclusion of each chapter targeted towards students and professors. In addition to a bibliography, it includes a very useful Company and Software Index towards the end of the book that lists all the different software applications that were discussed in the book and the corresponding page numbers, not only making it easy to find the sections where a particular software is discussed, but also to get an at-a-glance overview of the extensive range of BIM and related applications that are currently available.

It is not often that practitioners in a field can get the benefits of an extensively researched and meticulously written book, showing evidence of years of work rather than something that has been quickly put together in the course of a few months, as most industry-focused books tend to be. The AEC industry has been fortunate to have this distinguished team of authors put their efforts into creating *The BIM Handbook*. Thanks to them, anyone in the AEC industry looking for a deeper understanding of BIM now knows exactly where to look for it. It brings together most of the current information about BIM, its

history, as well as its potential future in one convenient place. It is, of course, the must-have text book on BIM for all academic institutions who would like to teach or research this subject, given the academic and research credentials of its authors. There were many sections of the book that were illuminating and insightful even to someone like me, who has been analyzing and writing about AEC technology for close to ten years now. This helps to gauge how much value the book would bring to an AEC practitioner whose prime focus would be on the actual process of design, construction, or operation of a building rather than a full-time study of the technologies supporting it. True to its title, *The BIM Handbook* indeed serves as a handy reference book on BIM for anyone working in the AEC industry who needs to understand its current and future technological state of the art, as BIM is not only what is “in” today but is also the foundation on which smarter and better solutions will be built going forward.

Lachmi Khemlani, Ph.D.  
Founder and Editor, AECbytes

# Preface

---

This book is about a new approach to design, construction, and facility management called *building information modeling* (BIM). It provides an in-depth understanding of BIM technologies, the business and organizational issues associated with its implementation, and the profound impacts that effective use of BIM can provide to all parties involved in a facility over its lifetime. The book explains how designing, constructing, and operating buildings with BIM differs from pursuing the same activities in the traditional way using drawings, whether paper or electronic.

BIM is beginning to change the way buildings look, the way they function, and the ways in which they are built. Throughout the book, we have intentionally and consistently used the term “BIM” to describe an activity (meaning *building information modeling*), rather than an object (*building information model*). This reflects our belief that BIM is not a thing or a type of software but a human activity that ultimately involves broad process changes in design, construction and facility management.

Perhaps most important is that BIM creates significant opportunity for society at large to achieve more sustainable building construction processes and higher performance facilities with fewer resources and lower risk than can be achieved using traditional practices.

## **Why a BIM Handbook?**

Our motivation in writing this book was to provide a thorough and consolidated reference to help students and practitioners in the construction industry learn about this exciting new approach, in a format independent of the commercial interests that guide vendors’ literature on the subject. There are many truths and myths in the generally accepted perceptions of the state of the art of BIM. We hope that *The BIM Handbook* will help reinforce the truths, dispel the myths, and guide our readers to successful implementations. Some well-meaning decision-makers and practitioners in the construction industry at-large have had disappointing experiences after attempting to adopt BIM, because their efforts and expectations were based on misconceptions and inadequate planning. If this book can help readers avoid these frustrations and costs, we will have succeeded.

Collectively, the authors have a wealth of experience with BIM, both with the technologies it uses and the processes it supports. We believe that BIM represents a paradigm change that will have far-reaching impacts and

benefits, not only for those in the construction industry but for society at-large, as better buildings are built that consume fewer materials and require less labor and capital resources and that operate more efficiently. We make no claim that the book is objective in terms of our judgment of the necessity for BIM. At the same time, of course, we have made every effort to ensure the accuracy and completeness of the facts and figures presented.

### **Who Is *The BIM Handbook* For, and What Is in It?**

*The BIM Handbook* is addressed to building developers, owners, managers, and inspectors; to architects, engineers of all disciplines, construction contractors, and fabricators; and to students of architecture, civil engineering, and building construction. It reviews Building Information Modeling and its related technologies, its potential benefits, its costs and needed infrastructure. It also discusses the present and future influences of BIM on regulatory agencies; legal practice associated with the building industry; and manufacturers of building products—it is directed at readers in these areas. A rich set of BIM case studies are presented and various BIM tools and technologies are described. Current and future industry and societal impacts are also explored.

The book has four sections:

- I. Chapters 1, 2, and 3 provide an introduction to BIM and the technologies that support it. These chapters describe the current state of the construction industry, the potential benefits of BIM, the technologies underlying BIM including parametric modeling of buildings and interoperability.
- II. Chapters 4, 5, 6, and 7 provide discipline-specific perspectives of BIM. They are aimed at owners (Chapter 4), designers of all kinds (Chapter 5), general contractors (Chapter 6), and subcontractors and fabricators (Chapter 7).
- III. Chapter 8 discusses potential impacts and future trends associated with the advent of BIM-enabled design, construction, and operation of buildings. Current trends are described and extrapolated through the year 2015, as are forecasts of potential long-term developments and the research needed to support them through 2020.
- IV. Chapter 9 provides ten detailed cases studies of BIM in the design and construction industry that demonstrate its use for feasibility studies, conceptual design, detail design, estimating, detailing, coordination, construction planning, logistics, operations and many other common construction activities. The case studies include buildings with signature architectural and structural designs (such as the Aviva Stadium in Dublin, the 100 11th Avenue apartment building facade in New York City, and the environmentally friendly Music Hall in Helsinki) as well as a wide range of fairly common buildings (a Marriott Hotel renovation, a hospital, a high-rise office building, and a mixed commercial and retail

development, and a coast-guard training facility). There is also a study of a single tower cable-stayed bridge in Finland.

### **What's New in This Edition?**

BIM is developing rapidly, and it is difficult to keep up with the advances in both technology and practice. Integrated Project Delivery (IPD) is a collaborative contracting paradigm that has been developed and adopted within the three years since we completed the first edition. BIM tools are increasingly used to support sustainable design, construction, and operation. There has been increasing support by BIM for lean design and construction methods which are highlighted throughout the book. Some innovations we predicted would become commercial by 2012, such as tracking of building components using BIM and radio-frequency ID tagging, have already been used in practice.

This edition not only addresses these themes and updates the material related to the BIM applications; it also introduces sections on new technologies, such as laser scanning and BIM servers. It also includes six new case studies.

### **How to use *The BIM Handbook***

Many readers will find the *Handbook* a useful resource whenever they are confronted with new terms and ideas related to BIM in the course of their work or study. A thorough first-reading, while not essential, is of course the best way to gain a deeper understanding of the significant changes that BIM is bringing to the AEC/FM industry.

The first section (Chapters 1–3) is recommended for all readers. It gives a background to the commercial context and the technologies for BIM. Chapter 1 lists many of the potential benefits that can be expected. It first describes the difficulties inherent in current practice within the U.S. construction industry and its associated poor productivity and higher costs. It then describes various approaches to procuring construction, such as traditional design-bid-build, design-build, and others, describing the pros and cons for each in terms of realizing benefits from the use of BIM. It describes newer integrated project delivery (IPD) approaches that are particularly useful when supported by BIM. Chapter 2 details the technological foundations of BIM, in particular parametric and object-oriented modeling. The history of these technologies and their current state of the art are described. The chapter then reviews the leading commercial application platforms for generating building information models. Chapter 3 deals with the intricacies of interoperability, including how building information can be communicated and shared from profession to profession and from application to application. The relevant standards, such as IFC (Industry Foundation Classes) and the U.S. National BIM Standards are covered in detail. Chapters 2 and 3 can also be used as a reference for the technical aspects of parametric modeling and interoperability.

Readers who desire specific information on how they can adopt and implement BIM in their companies can find the details they need in the

relevant chapter for their profession within Chapters 4–7. You may wish to read the chapter closest to your area of interest and then only the executive summaries of each of the other chapters. There is some overlap within these chapters, where issues are relevant to multiple professions (for example, subcontractors will find relevant information in Chapters 6 and 7). These chapters make frequent reference to the set of detailed case studies provided in Chapter 9.

Those who wish to learn about the long-term technological, economic, organizational, societal, and professional implications of BIM and how they may impact your educational or professional life will find an extensive discussion of these issues in Chapter 8.

The case studies in Chapter 9 each tell a story about different professionals' experiences using BIM on their projects. No one case study represents a "complete" implementation or covers the entire building lifecycle. In most cases, the building was not complete when the study was written. But taken together, they paint a picture of the variety of uses and the benefits and problems that these pioneering firms have already experienced. They illustrate what could be achieved with existing BIM technology at the start of the 21st century. There are many lessons learned that can provide assistance to our readers and guide practices in future efforts.

Finally, students and professors are encouraged to make use of the study questions and exercises provided at the conclusion of each chapter.

## **Acknowledgments**

Naturally, we are indebted first and foremost to our families, who have all borne the brunt of the extensive time we have invested in this book. Our thanks and appreciation for the highly professional work of Lauren Poplawski, Editorial Program Coordinator, and to Kathryn Bourgoine, Acquisitions Editor, both at John Wiley and Sons.

Our research for the book was greatly facilitated by numerous builders, designers, and owners, representatives of software companies and government agencies; we thank them all sincerely. Five of the case studies were originally prepared by graduate students in the College of Architecture at Georgia Tech, and others were initially drafted by students at the School of the Built Environment at the University of Salford, and at the Tallinn University of Applied Sciences; we thank them, and their efforts are acknowledged personally at the end of each relevant case study. The case studies were made possible through the very generous contributions of the project participants who corresponded with us extensively and shared their understanding and insights.

Finally, we are grateful to Lachmi Khemlani for her enlightening foreword to this second edition and for her significant contributions to BIM, reflected in her publication of AECbytes. Finally, we are grateful to Jerry Laiserin for his enlightening foreword in the first edition and for helping to initiate the original idea for *The BIM Handbook*.



# CHAPTER 1

---

## BIM Handbook Introduction

---

### 1.0 EXECUTIVE SUMMARY

Building Information Modeling (BIM) is one of the most promising developments in the architecture, engineering, and construction (AEC) industries. With BIM technology, one or more accurate virtual models of a building are constructed digitally. They support design through its phases, allowing better analysis and control than manual processes. When completed, these computer-generated models contain precise geometry and data needed to support the construction, fabrication, and procurement activities through which the building is realized.

BIM also accommodates many of the functions needed to model the lifecycle of a building, providing the basis for new design and construction capabilities and changes in the roles and relationships among a project team. When adopted well, BIM facilitates a more integrated design and construction process that results in better quality buildings at lower cost and reduced project duration.

This chapter begins with a description of existing construction practices, and it documents the inefficiencies inherent in these methods. It then explains

both the technology behind BIM and recommends ways to best take advantage of the new business processes it enables for the entire lifecycle of a building. It concludes with an appraisal of various problems one might encounter when converting to BIM technology.

---

## 1.1 INTRODUCTION

To better understand the significant changes that BIM introduces, this chapter begins with a description of current paper-based design and construction methods and the predominant business models now in use by the construction industry. It then describes various problems associated with these practices, outlines what BIM is, and explains how it differs from 2D and 3D computer-aided design (CAD). We give a brief description of the kinds of problems that BIM can solve and the new business models that it enables. The chapter concludes with a presentation of the most significant problems that may arise when using the technology, which is now only in its early phase of development and use.

---

## 1.2 THE CURRENT AEC BUSINESS MODEL

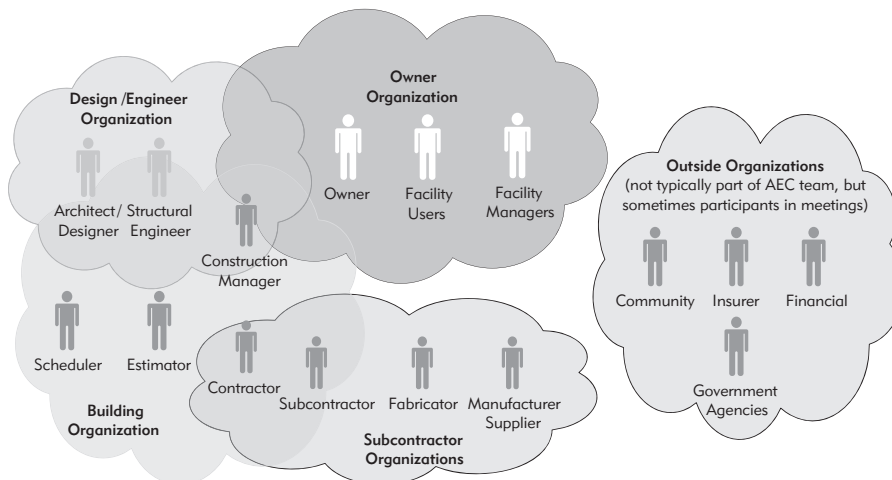
Currently, the facility delivery process remains fragmented, and it depends on paper-based modes of communication. Errors and omissions in paper documents often cause unanticipated field costs, delays, and eventual lawsuits between the various parties in a project team. These problems cause friction, financial expense, and delays. Efforts to address such problems have included: alternative organizational structures such as the design-build method; the use of real-time technology, such as project Web sites for sharing plans and documents; and the implementation of 3D CAD tools. Though these methods have improved the timely exchange of information, they have done little to reduce the severity and frequency of conflicts caused by paper documents or their electronic equivalents.

One of the most common problems associated with 2D-based communication during the design phase is the considerable time and expense required to generate critical assessment information about a proposed design, including cost estimates, energy-use analysis, structural details, and so forth. These analyses are normally done last, when it is already too late to make important changes. Because these iterative improvements do not happen during the design phase, *value engineering* must then be undertaken to address inconsistencies, which often results in compromises to the original design.

Regardless of the contractual approach, certain statistics are common to nearly all large-scale projects (\$10 M or more), including the number of people involved and the amount of information generated. The following data was compiled by Maged Abdelsayed of Tardif, Murray & Associates, a construction company located in Quebec, Canada (Hendrickson 2003):

- Number of participants (companies): 420 (including all suppliers and sub-sub-contractors)
- Number of participants (individuals): 850
- Number of different types of documents generated: 50
- Number of pages of documents: 56,000
- Number of bankers boxes to hold project documents: 25
- Number of 4-drawer filing cabinets: 6
- Number of 20-inch-diameter, 20-year-old, 50-foot-high, trees used to generate this volume of paper: 6
- Equivalent number of Mega Bytes of electronic data to hold this volume of paper (scanned): 3,000 MB
- Equivalent number of compact discs (CDs): 6

It is not easy to manage an effort involving such a large number of people and documents, regardless of the contractual approach taken. Figure 1–1 illustrates the typical members of a project team and their various organizational boundaries.



**FIGURE 1–1**  
Conceptual diagram representing an AEC project team and the typical organizational boundaries.

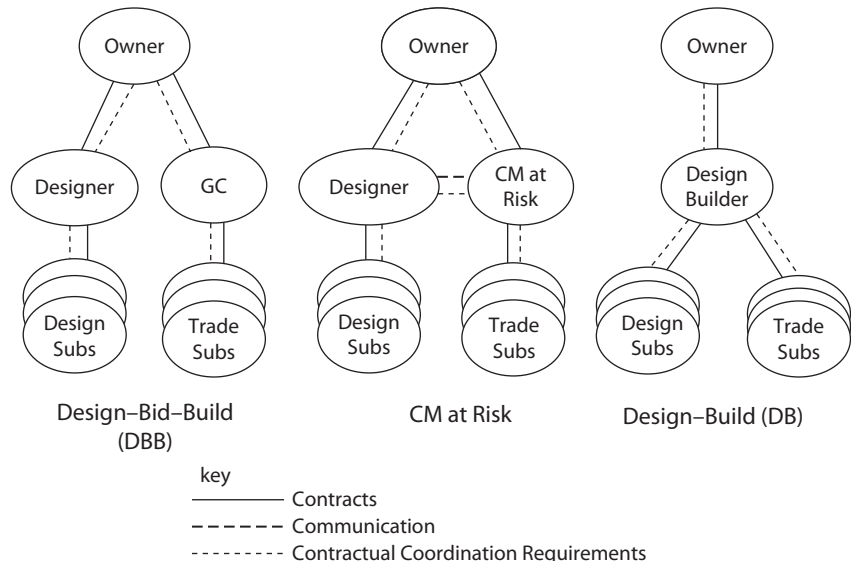
There are three dominant contract methods in the United States: Design-Bid-Build, Design-Build, and Construction Management at Risk. There are also many variations of these (Sanvido and Konchar 1999; Warne and Beard 2005). A fourth method, quite different from the first three, called “Integrated Project Delivery” is becoming increasingly popular with sophisticated building owners. These four approaches are now described in greater detail.

### 1.2.1 Design-Bid-Build

A significant percentage of buildings are built using the Design-Bid-Build (DBB) approach (almost 90 percent of public buildings and about 40 percent of private buildings in 2002) (DBIA 2007). The two major benefits of this approach are: more competitive bidding to achieve the lowest possible price for an owner; and less political pressure to select a given contractor. (The latter is particularly important for public projects.) Figure 1–2 schematically illustrates the typical DBB procurement process as compared to the typical Construction Management at Risk (CM at Risk) and Design-Build (DB) processes (see Section 1.2.2)

In the DBB model, the client (owner) hires an architect, who then develops a list of building requirements (a program) and establishes the project’s design objectives. The architect proceeds through a series of phases: schematic design, design development, and contract documents. The final documents must fulfill the program and satisfy local building and zoning codes. The architect either hires employees or contracts consultants to assist in designing

**FIGURE 1-2**  
Schematic diagram of Design-Bid-Build, CM at Risk, and Design-Build processes.



structural, HVAC, piping, and plumbing components. These designs are recorded on drawings (plans, elevations, 3D visualizations), which must then be coordinated to reflect all of the changes as they are identified. The final set of drawings and specifications must contain sufficient detail to facilitate construction bids. Because of potential liability, an architect may choose to include fewer details in the drawings or insert language indicating that the drawings cannot be relied on for dimensional accuracy. These practices often lead to disputes with the contractor, as errors and omissions are detected and responsibility and extra costs reallocated.

Stage two involves obtaining bids from general contractors. The owner and architect may play a role in determining which contractors can bid. Each contractor must be sent a set of drawings and specifications which are then used to compile an *independent quantity survey*. These quantities, together with the bids from subcontractors, are then used to determine their *cost estimate*. Subcontractors selected by the contractors must follow the same process for the part of the project that they are involved with. Because of the effort required, contractors (general and subcontractors) typically spend approximately 1 percent of their estimated costs in compiling bids.<sup>1</sup> If a contractor wins approximately one out of every 6 to 10 jobs that they bid on, the cost per successful bid averages from 6 to 10 percent of the entire project cost. This expense then gets added to the general and subcontractors' overhead costs.

The winning contractor is usually the one with the lowest responsible bid, including work to be done by the general contractor and selected subcontractors. Before work can begin, it is often necessary for the contractor to redraw some of the drawings to reflect the construction process and the phasing of work. These are called *general arrangement drawings*. The subcontractors and fabricators must also produce their own *shop drawings* to reflect accurate details of certain items, such as precast concrete units, steel connections, wall details, piping runs, and the like.

The need for accurate and complete drawings extends to the shop drawings, as these are the most detailed representations and are used for actual fabrication. If these drawings are inaccurate or incomplete, or if they are based on drawings that already contain errors, inconsistencies, or omissions, then expensive time-consuming conflicts will arise in the field. The costs associated with these conflicts can be significant.

---

<sup>1</sup> This is based on two of the authors' personal experience in working with the construction industry. This cost includes the expense of obtaining bid documents, performing quantity takeoff, coordinating with suppliers and subcontractors, and the cost estimating processes.

Inconsistency, inaccuracy, and uncertainty in design make it difficult to fabricate materials offsite. As a result, most fabrication and construction must take place onsite and only after exact conditions are established. Onsite construction work is more costly, more time-consuming, and prone to produce errors that would not occur if the work were performed in a factory environment where costs are lower and quality control is better.

Often during the construction phase, numerous changes are made to the design as a result of previously unknown errors and omissions, unanticipated site conditions, changes in material availabilities, questions about the design, new client requirements, and new technologies. These need to be resolved by the project team. For each change, a procedure is required to determine the cause, assign responsibility, evaluate time and cost implications, and address how the issue will be resolved. This procedure, whether initiated in writing or with the use of a Web-based tool, involves a *Request for Information* (RFI), which must then be answered by the architect or other relevant party. Next a *Change Order* (CO) is issued and all impacted parties are notified about the change, which is communicated together with needed changes in the drawings. These changes and resolutions frequently lead to legal disputes, added costs, and delays. Web site products for managing these transactions do help the project team stay on top of each change, but because they do not address the source of the problem, they are of marginal benefit.

Problems also arise whenever a contractor bids below the estimated cost in order to win the job. Contractors often abuse the change process to recoup losses incurred from the original bid. This, of course, leads to more disputes between the owner and project team.

In addition, the DBB process requires that the procurement of all materials be held until the owner approves the bid, which means that long lead time items may extend the project schedule. For this and other reasons (described below), the DBB approach often takes longer than the DB approach.

The final phase is commissioning the building, which takes place after construction is finished. This involves testing the building systems (heating, cooling, electrical, plumbing, fire sprinklers, and so forth) to make sure they work properly. Depending on contract requirements, final drawings are then produced to reflect all *as-built changes*, and these are delivered to the owner along with all manuals for installed equipment. At this point, the DBB process is completed.

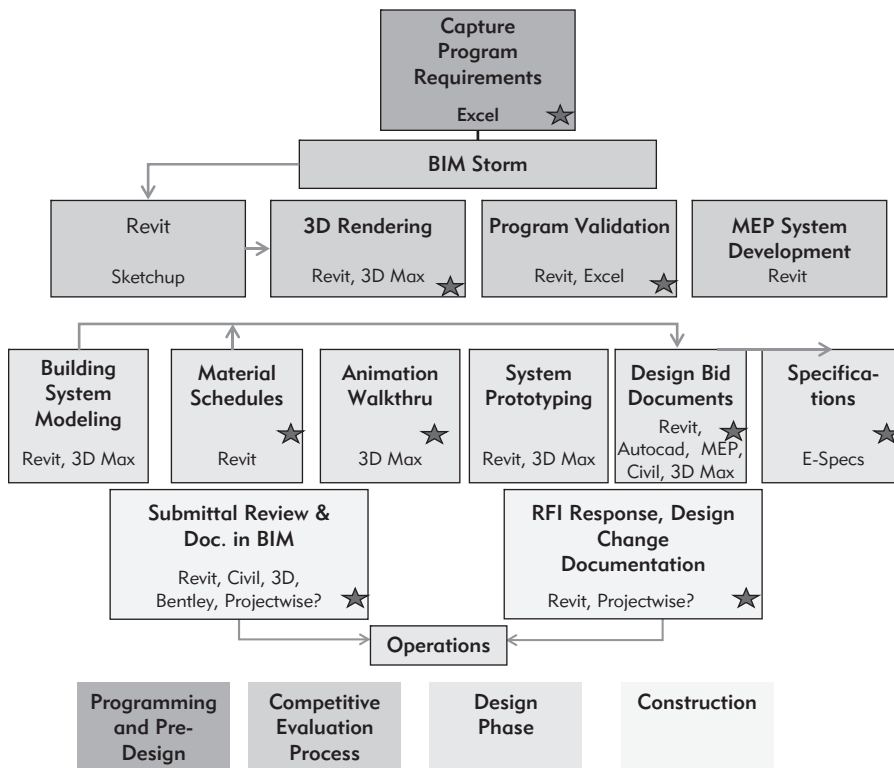
Because all of the information provided to the owner is conveyed in 2D (on paper or equivalent electronic files), the owner must put in a considerable amount of effort to relay all relevant information to the facility management team charged with maintaining and operating the building. The process is time-consuming, prone to error, costly, and remains a significant barrier.

As a result of these problems, the DBB approach is probably not the most expeditious or cost-efficient approach to design and construction. Other approaches have been developed to address these problems.

### 1.2.2 Design-Build

The design-build (DB) process was developed to consolidate responsibility for design and construction into a single contracting entity and to simplify the administration of tasks for the owner (Beard et al. 2005). Figure 1–3 illustrates this process.

In this model, the owner contracts directly with the design-build team (normally a contractor with a design capability or working with an architect) to develop a well-defined building program and a schematic design that meets the owner's needs. The DB contractor then estimates the total cost and time needed to design and construct the building. After all modifications requested by the owner are implemented, the plan is approved and the final budget for the project is established. It is important to note that because the DB model



**FIGURE 1–3**  
Adapted from workflow and deliverables for LACCD BIM standard on design-build projects (only the BIM-related workflows are shown).

allows for modifications to be made to the building's design earlier in the process, the amount of money and time needed to incorporate these changes is also reduced. The DB contractor establishes contractual relationships with specialty designers and subcontractors as needed. These are usually based on a fixed price, lowest bid basis. After this point, construction begins and any further changes to the design (within predefined limits) become the responsibility of the DB contractor. The same is true for errors and omissions. It is not necessary for detailed construction drawings to be complete for all parts of the building prior to the start of construction on the foundation and early building elements. As a result of these simplifications, the building is typically completed faster, with far fewer legal complications, and at a somewhat reduced total cost. On the other hand, there is little flexibility for the owner to make changes after the initial design is approved and a contract amount is established.

The DB model is becoming more common in the United States and is used widely abroad. Data is not currently available from U.S. government sources, but the Design Build Institute of America (DBIA) estimates that, in 2006, approximately 40 percent of construction projects in the United States relied on a variation of the DB procurement approach. Higher percentages (50 to 70 percent) were measured for some government organizations (Navy, Army, Air Force, and GSA).

The use of BIM within a DB model is clearly advisable. The Los Angeles Community College District (LACCD) has established a clear set of guidelines for this use of BIM for its design-build projects (see <http://standards.build-laccd.org/projects/dcs/pub/BIM%20Standards/released/PV-001.pdf>). Figure 1-3 is adapted from this paper and shows the BIM-related workflow and deliverables for this standard.

### **1.2.3 Construction Management at Risk**

Construction management at risk (CM@R) project delivery is a method in which an owner retains a designer to furnish design services and also retains a construction manager to provide construction management services for a project throughout the preconstruction and construction phases. These services may include preparation and coordination of bid packages, scheduling, cost control, value engineering, and construction administration. The construction manager is usually a licensed general contractor and guarantees the cost of the project (guaranteed maximum price, or GMP). The owner is responsible for the design before a GMP can be set. Unlike DBB, CM@R brings the constructor into the design process at a stage where they can have definitive input. The value of the delivery method stems from the early involvement of the contractor and the reduced liability of the owner for cost overruns.



### 1.2.4 Integrated Project Delivery

Integrated project delivery (IPD) is a relatively new procurement process that is gaining popularity as the use of BIM expands and the AEC facility management (AEC/FM) industry learns how to use this technology to support integrated teams. There are multiple approaches to IPD as the industry experiments with this approach. The American Institute of Architecture (AIA) has prepared sample contract forms for a family of IPD versions (AIA 2010). They have also published a useful Guide to IPD (AIA 2010). In all cases, integrated projects are distinguished by effective collaboration among the owner, the prime (and possibly sub-) designers, the prime (and possibly key sub-) contractor(s). This collaboration takes place from early design and continues through project handover. The key concept is that this project team works together using the best collaborative tools at their disposal to ensure that the project will meet owner requirements at significantly reduced time and cost. Either the owner needs to be part of this team to help manage the process or a consultant must be hired to represent the owner's interests, or both may participate. The tradeoffs that are always a part of the design process can best be evaluated using BIM—cost, energy, functionality, esthetics, and constructability. Thus, BIM and IPD go together and represent a clear break with current linear processes that are based on paper representation exchange of information. Clearly the owner is the primary beneficiary of IPD, but it does require that they understand enough to participate and specify in the contracts what they want from the participants and how it will be achieved. The legal issues of IPD are very important and are discussed in Chapters 4 and 6. There are several case studies of IPD projects presented in Chapter 9.

### 1.2.5 What Kind of Building Procurement Is Best When BIM Is Used?

There are many variations of the design-to-construction business process, including the organization of the project team, how the team members are paid, and who absorbs various risks. There are lump-sum contracts, cost plus a fixed or percentage fee, various forms of negotiated contracts, and so forth. It is beyond the scope of this book to outline each of these and the benefits and problems associated with them (but see Sanvido and Konchar, 1999; and Warne and Beard, 2005).

With regard to the use of BIM, the general issues that either enhance or diminish the positive changes that this technology offers depends on how well and at what stage the project team works collaboratively on one or more digital models. The DBB approach presents the greatest challenge to the use of BIM because the contractor does not participate in the design process and thus must

build a new building model after design is completed. The DB approach may provide an excellent opportunity to exploit BIM technology, because a single entity is responsible for design and construction. The CM@R approach allows early involvement of the constructor in the design process which increases the benefit of using BIM and other collaboration tools. Various forms of integrated project delivery are being used to maximize the benefits of BIM and “Lean” (less wasteful) processes. Other procurement approaches can also benefit from the use of BIM but may achieve only partial benefits, particularly if BIM technology is not used collaboratively during the design phase.

### 1.3 DOCUMENTED INEFFICIENCIES OF TRADITIONAL APPROACHES

This section documents how traditional practices contribute unnecessary waste and errors. Evidence of poor field productivity is illustrated in a graph developed by the Center for Integrated Facility Engineering (CIFE) at Stanford University (CIFE 2007). The impact of poor information flow and redundancy is illustrated using the results of a study performed by the National Institute of Standards and Technology (NIST) (Gallaher et al. 2004).

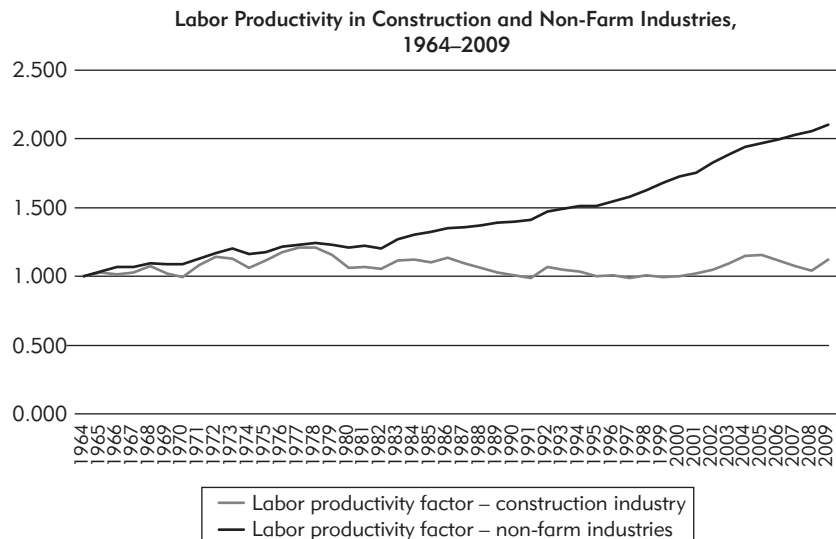
#### 1.3.1 CIFE Study of Construction Industry Labor Productivity

Extra costs associated with traditional design and construction practices have been documented through various research studies. Figure 1–4, developed by

**FIGURE 1–4**

Indexes of labor productivity for construction and nonfarm industries, 1964–2009.

Adapted from research by Paul Teicholz at CIFE.



one of the authors, illustrates productivity within the U.S. field construction industry relative to all nonfarm industries over a period of 45 years, from 1964 through 2009. The data was calculated by dividing constant contract dollars (from the Department of Commerce) by field worker-hours of labor for those contracts (from the Bureau of Labor Statistics). These contracts include architectural and engineering costs as well as cost for materials and for the delivery of offsite components to the site. Costs associated with the installation of heavy production equipment, such as printing presses, stamping machines, and the like, are not included. The amount of worker-hours required for labor excludes offsite work, such as steel fabrication, precast concrete, and so forth, but does include the installation labor for these materials. During this 44-year-long period, the productivity of nonfarm industries (including construction) has more than doubled. Meanwhile, labor productivity within the construction industry is relatively unchanged and is now estimated to be about 10 percent less than what it was in 1964. Labor represents about 40 to 60 percent of construction's estimated costs (depending on the type of structure). Owners were actually paying approximately 5 percent more in 2009 than they would have paid for the same building in 1964. Of course, many material and technological improvements have been made to buildings in the last four decades. The results are perhaps better than they appear, because quality has increased substantially and offsite prefabrication is becoming a bigger factor. On the other hand, manufactured products are also more complex than they used to be, but they now can be produced at significantly lower cost. The replacement of manual labor with automated equipment has resulted in lower labor costs and increased quality. But the same cannot be said for construction practices considering the industry as a whole.

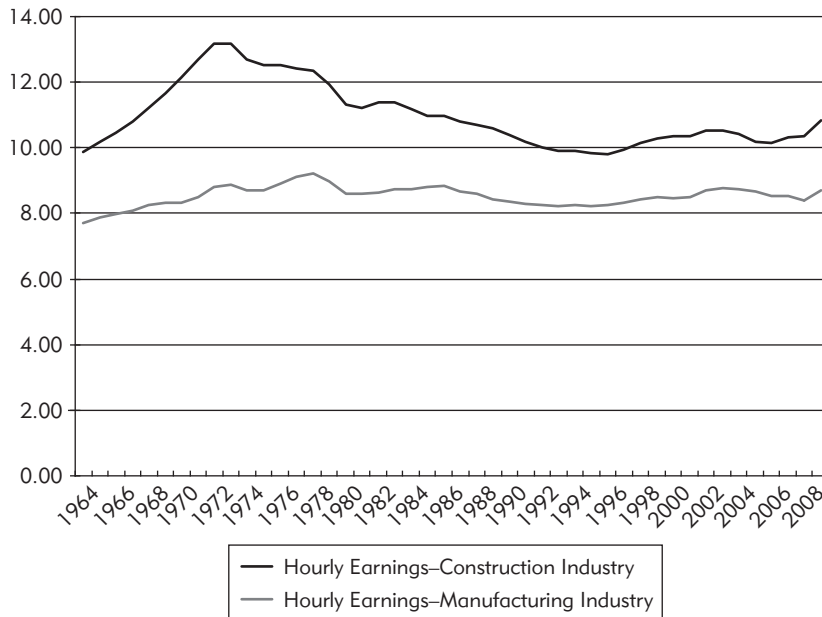
Contractors have made greater use of offsite components which take advantage of factory conditions and specialized equipment. Clearly this has allowed for higher quality and lower cost production of components, as compared to onsite work (Eastman and Sacks 2008). Although the cost of these components is included in our construction cost data, the labor is not. This tends to make onsite construction productivity appear better than it actually is. The extent of this error, however, is difficult to evaluate because the total cost of offsite production is not well-documented over the total period covered by these statistics.<sup>2</sup>

---

<sup>2</sup>From 1997–2008 the cost of prefabricated wood and steel components represented about 5.3 percent of total construction value put in place or about 9.7 percent of the value of the material, supplies, and fuel used for construction (from Economic Census data).

While the reasons for the apparent decrease in construction productivity are not completely understood, the statistics are dramatic and point at significant structural impediments within the construction industry. It is clear that efficiencies achieved in the manufacturing industry through automation, the use of information systems, better supply chain management, and improved collaboration tools, have not yet been achieved in field construction. Possible reasons for this include:

- Sixty-five percent of construction firms consist of fewer than five people, making it difficult for them to invest in new technology; even the largest firms account for less than 0.5 percent of total construction volume and are not able to establish industry leadership (see Figure 6–1 in Chapter 6).
- The real inflation-adjusted wages and the benefit packages of construction workers have stagnated over this time period. Union participation has declined and the use of immigrant workers has increased, discouraging the need for labor-saving innovations. While innovations have been introduced, such as nail guns, larger and more effective earth moving equipment, and better cranes, the productivity improvements associated with them have not been sufficient to change overall field labor productivity.
- Additions, alterations, or reconstruction work represents about 23 percent and maintenance and repair represents about 10 to 12 percent of construction volume. It is more difficult to use capital-intensive methods for these kinds of work. It is labor intensive and likely to remain so. New work represents only about 64 percent of total construction volume.
- The adoption of new and improved business practices within both design and construction has been noticeably slow and limited primarily to larger firms. In addition, the introduction of new technologies has been fragmented. Often, it remains necessary to revert back to paper or 2D CAD drawings so that all members of a project team are able to communicate with each other and to keep the pool of potential contractors and subcontractors bidding on a project sufficiently large. Municipal governments almost all require paper submittals for construction permit reviews. For these reasons, paper use maintains a strong grip on the industry.
- Whereas manufacturers often have long-term agreements and collaborate in agreed-upon ways with the same partners, construction projects typically involve different partners working together for a period of time and then dispersing. As a result, there are few or no opportunities to realize improvements over time through applied learning. Rather, each

**FIGURE 1-5**

Trends in real wages (1990 U.S. \$) for manufacturing and construction hourly workers, 1974–2008.

BLS, Series ID: EES00500006.

partner acts to protect him- or herself from potential disputes that could lead to legal difficulties by relying on antiquated and time-consuming processes that make it difficult or impossible to implement resolutions quickly and efficiently. Of course, this translates to higher cost and time expenditures.

Another possible cause for the construction industry's stagnant productivity is that onsite construction has not benefited significantly from automation. Thus, field productivity relies on qualified training of field labor. Figure 1–5 shows that, since 1974, compensation for hourly workers has steadily declined with the increase in use of nonunion immigrant workers with little prior training. The lower cost associated with these workers may have discouraged efforts to replace field labor with automated (or offsite) solutions. The fact that average hourly wages for manufacturing are lower than those in construction may indicate that automation in both industries is less dependent on the cost of labor than on whether the basic processes are able to be automated (factory versus field work environments and the like).

### 1.3.2 NIST Study of Cost of Construction Industry Inefficiency

The National Institute of Standards and Technology (NIST) performed a study of the additional cost incurred by building owners as a result of inadequate

interoperability (Gallaher et al. 2004). The study involved both the exchange and management of information, in which individual systems were unable to access and use information imported from other systems. In the construction industry, incompatibility between systems often prevents members of the project team from sharing information rapidly and accurately; it is the cause of numerous problems, including added costs, and so forth. The NIST study included commercial, industrial, and institutional buildings and focused on new and “set in place” construction taking place in 2002. The results showed that inefficient interoperability accounted for an increase in construction costs by \$6.12 per square foot for new construction and an increase in \$0.23 per square foot for operations and maintenance (O&M), resulting in a total added cost of \$15.8 billion. Table 1–1 shows the breakdown of these costs and to which stakeholder they were applied.

In the NIST study, the cost of inadequate interoperability was calculated by comparing current business activities and costs with hypothetical scenarios in which there was seamless information flow and no redundant data entry. NIST determined that the following costs resulted from inadequate interoperability:

- Avoidance (redundant computer systems, inefficient business process management, redundant IT support staffing)
- Mitigation (manual reentry of data, request for information management)
- Delay (costs for idle employees and other resources)

**Table 1–1** Additional Costs of Inadequate Interoperability in the Construction Industry, 2002 (In \$M)

Stakeholder Group	Planning, Engineering, Design Phase	Construction Phase	O&M Phase	Total Added Cost
Architects and Engineers	\$1,007.2	\$147.0	\$15.7	\$1,169.8
General Contractors	\$485.9	\$1,265.3	\$50.4	\$1,801.6
Special Contractors and Suppliers	\$442.4	\$1,762.2		\$2,204.6
Owners and Operators	\$722.8	\$898.0	\$9,027.2	\$1,0648.0
<b>Total</b>	<b>\$2,658.3</b>	<b>\$4,072.4</b>	<b>\$9,093.3</b>	<b>\$15,824.0</b>
Applicable sf in 2002	1.1 billion	1.1 billion	39 billion	n/a
<b>Added cost/sf</b>	<b>\$2.42/sf</b>	<b>\$3.70/sf</b>	<b>\$0.23</b>	<b>n/a</b>

Source: Table 6.1 NIST study (Gallaher et al. 2004).

Of these costs, roughly 68 percent (\$10.6 billion) were incurred by building owners and operators. These estimates are speculative, due to the impossibility of providing accurate data. They are, however, significant and worthy of serious consideration and effort to reduce or avoid them as much as possible. Widespread adoption of BIM and the use of a comprehensive digital model throughout the lifecycle of a building would be a step in the right direction to eliminate such costs resulting from the inadequate interoperability of data.

---

## 1.4 BIM: NEW TOOLS AND NEW PROCESSES

This section gives an overall description of BIM-related terminology, concepts, and functional capabilities; and it addresses how these tools can improve business processes. Specific topics are discussed in further detail in the chapters indicated in parenthesis.

### 1.4.1 BIM Model Creation Tools (Chapter 2)

All CAD systems generate digital files. Older CAD systems produce plotted drawings. They generate files that consist primarily of vectors, associated line-types, and layer identifications. As these systems were further developed, additional information was added to these files to allow for blocks of data and associated text. With the introduction of 3D modeling, advanced definition and complex surfacing tools were added.

As CAD systems became more intelligent and more users wanted to share data associated with a given design, the focus shifted from drawings and 3D images to the data itself. A building model produced by a BIM tool can support multiple different views of the data contained within a drawing set, including 2D and 3D. A building model can be described by its content (what objects it describes) or its capabilities (what kinds of information requirements it can support). The latter approach is preferable, because it defines what you can do with the model rather than how the database is constructed (which will vary with each implementation).

The following is both the vision for and a definition of BIM technology provided by the National Building Information Modeling Standard (NBIMS) Committee of the National Institute of Building Sciences (NIBS) Facility Information Council (FIC). The NBIMS vision for BIM is “an improved

For the purpose of this book, we define BIM as a modeling technology and associated set of processes to produce, communicate, and analyze *building models*. Building models are characterized by:

- Building components that are represented with digital representations (objects) that carry computable graphic and data attributes that identify them to software applications, as well as parametric rules that allow them to be manipulated in an intelligent fashion.
- Components that include data that describe how they behave, as needed for analyses and work processes, for example, takeoff, specification, and energy analysis.
- Consistent and nonredundant data such that changes to component data are represented in all views of the component and the assemblies of which it is a part.
- Coordinated data such that all views of a model are represented in a coordinated way.

planning, design, construction, operation, and maintenance process using a standardized machine-readable information model for each facility, new or old, which contains all appropriate information created or gathered about that facility in a format useable by all throughout its lifecycle.” (NIBS 2008).

The scope of BIM directly or indirectly affects all stakeholders supporting the capital facilities industry. BIM is a fundamentally different way of creating, using, and sharing building lifecycle data. The terms *Building Information Model* and *Building Information Modeling* are often used interchangeably, reflecting the term’s growth to manage the expanding needs of the constituency.

The NBIMS Initiative categorizes the Building Information Model (BIM) three ways:

1. As a product
2. As an IT-enabled, open standards–based deliverable, and a collaborative process
3. As a facility lifecycle management requirement.

These categories support the creation of the industry information value chain, which is the ultimate evolution of BIM. This enterprise-level (industry-wide) scope of BIM is the area of focus for NBIMS, bringing together the various BIM implementation activities within stakeholder communities.



The methodologies used by NBIMS are rooted in the activities of the International Alliance for Interoperability (IAI), the Information Delivery Manuals (IDM) and Model View Definitions (MVDs), Industry Foundation Dictionaries (IFD), and the development of North American (NA) Information Exchanges that define user requirements and localized content supporting the NA approach to the various building lifecycle processes.

BIM supports a reevaluation of IT use in the creation and management of the facility's lifecycle. The stakeholders include real estate; ownership; finance; all areas of architecture, engineering, and construction (AEC); manufacturing and fabrication; facility maintenance, operations, and planning; regulatory compliance; management; sustainment; and disposal within the facility lifecycle. With society's growing environmental, sustainment, and security mandates, the need for open and reusable critical infrastructure data has grown beyond the needs of those currently supplying services and products to the industry. First-responders, government agencies, and other organizations also need this data.

BIM moves the industry forward from current task automation of project and paper-centric processes (3D CAD, animation, linked databases, spreadsheets, and 2D CAD drawings) toward an integrated and interoperable workflow where these tasks are collapsed into a coordinated and collaborative process that maximizes computing capabilities, Web communication, and data aggregation into information and knowledge capture. All of this is used to simulate and manipulate reality-based models to manage the built environment within a fact-based, repeatable and verifiable decision process that reduces risk and enhances the quality of actions and product industry-wide.

The list in the following section is intended to provide a starting point for evaluating specific BIM software tools. See Chapter 2 for more detailed information about BIM technology and an analysis of current BIM tools.

### 1.4.2 Definition of Parametric Objects (Chapter 2)

The concept of parametric objects is central to understanding BIM and its differentiation from traditional 3D objects. Parametric BIM objects are defined as follows:

- Consist of geometric definitions and **associated data and rules**.
- Geometry is integrated **nonredundantly**, and allows for no inconsistencies. When an object is shown in 3D, the shape cannot be represented internally redundantly, for example, as multiple 2D views. A plan and elevation of a given object must always be consistent. Dimensions cannot be “fudged.”
- Parametric rules for objects **automatically modify associated geometries** when inserted into a building model or when changes are made to

associated objects. For example, a door will fit automatically into a wall, a light switch will automatically locate next to the proper side of the door, a wall will automatically resize itself to butt to a ceiling or roof, and so forth.

- Objects can be defined at **different levels of aggregation**, so we can define a wall as well as its related components. Objects can be defined and managed at any number of hierarchy levels. For example, if the weight of a wall subcomponent changes, the weight of the wall should also change.
- Objects' rules can identify when a particular change violates **object feasibility** regarding size, manufacturability, and so forth.
- Objects have the ability to **link to or receive, broadcast, or export sets of attributes**, for example, structural materials, acoustic data, energy data, and the like, to other applications and models.

Technologies that allow users to produce building models that consist of parametric objects are considered BIM authoring tools. In Chapter 2 we elaborate the discussion of parametric technologies and discuss common capabilities in BIM tools including features to automatically extract consistent drawings and reports of geometric parameters. In Chapters 4 through 7 we discuss these capabilities and others and their potential benefits to various AEC practitioners and building owners.

### 1.4.3 Support for Project Team Collaboration (Chapter 3)

Open interfaces should allow for the import of relevant data (for creating and editing a design) and export of data in various formats (to support integration with other applications and workflows). There are two primary approaches for such integration: (1) to stay within one software vendor's products or (2) to use software from various vendors that can exchange data using industry-supported standards. The first approach may allow for tighter and easier integration among products in multiple directions. For example, changes to the architectural model will generate changes to the mechanical systems model, and vice versa. This requires, however, that all members of a design team use software provided from the same vendor.

The second approach uses either proprietary or open-source (publicly available and supported standards) to define building objects (Industry Foundation Classes, or IFCs). These standards may provide a mechanism for interoperability among applications with different internal formats. This approach provides more flexibility at the expense of possibly reduced interoperability, especially if the various software programs in use for a given project do not support, or only partially support with some data loss, the same exchange standards. This allows objects from one BIM application to be exported from

or imported into another (see Chapter 3 for an extensive discussion of collaboration technology).

---

## 1.5 WHAT IS NOT BIM TECHNOLOGY?

The term *BIM* is a popular buzzword used by software developers to describe the capabilities that their products offer. As such, the definition of what constitutes BIM technology is subject to variation and confusion. To deal with this confusion, it is useful to describe modeling solutions that **do not** utilize BIM design technology. These include tools that create the following kinds of models:

**Models that contain 3D data only and no (or few) object attributes.** These are models that can only be used for graphic visualizations and have no intelligence at the object level. They are fine for visualization but provide little or no support for data integration and design analysis. An example is Google's SketchUp application which is excellent for rapid development of building schematic designs, but limited use for any other type of analysis because it has no knowledge of the objects in the design other than their geometry and appearance for visualization.

**Models with no support of behavior.** These are models that define objects but cannot adjust their positioning or proportions because they do not utilize parametric intelligence. This makes changes extremely labor intensive and provides no protection against creating inconsistent or inaccurate views of the model.

**Models that are composed of multiple 2D CAD reference files that must be combined to define the building.** It is impossible to ensure that the resulting 3D model will be feasible, consistent, countable, and display intelligence with respect to the objects contained within it.

**Models that allow changes to dimensions in one view that are not automatically reflected in other views.** This allows for errors in the model that are very difficult to detect (similar to overriding a formula with a manual entry in a spreadsheet).

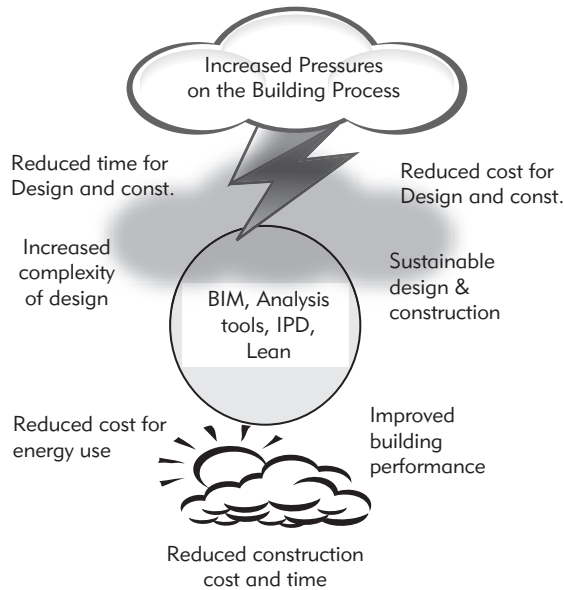
---

## 1.6 WHAT ARE THE BENEFITS OF BIM? WHAT PROBLEMS DOES IT ADDRESS?

BIM technology can support and improve many business practices. Although the AEC/FM (facility management) industry is in the early days of BIM use,

**FIGURE 1-6**

BIM technology and associated processes can help to respond to the increasing pressures on a building over its lifecycle.



significant improvements have already been realized (compared to traditional 2D CAD or paper-based practices). Though it is unlikely that all of the advantages discussed below are currently in use, we have listed them to show the entire scope of changes that can be expected as BIM technology develops. Figure 1-6 illustrates how BIM technology and associated processes are at the heart of how the building design and construction process can respond to the increasing pressures of greater complexity, faster development, improved sustainability while reducing the cost of the building and its subsequent use. Traditional practice is not able to respond to these pressures. The subsequent sections briefly describe how this improved performance can be achieved. The goal of this book is to provide the necessary knowledge to allow a reader to understand both the technology and business processes that underlie BIM.

### 1.6.1 Preconstruction Benefits to Owner (Chapters 4 and 5)

#### *Concept, Feasibility, and Design Benefits*

Before owners engage an architect, it is necessary to determine whether a building of a given size, quality level, and desired program requirements can be built within a given cost and time budget. In other words, can a given building meet the financial requirements of an owner? If these questions can be answered with relative certainty, owners can then proceed with the expectation that their goals are achievable. Finding out that a particular design is

significantly over budget after a considerable amount of time and effort has been expended is wasteful. An approximate (or “macro”) building model built into and linked to a cost database can be of tremendous value and assistance to an owner. This is described in further detail in Chapter 4.

### ***Increased Building Performance and Quality***

Developing a *schematic model* prior to generating a *detailed building model* allows for a more careful evaluation of the proposed scheme to determine whether it meets the building’s functional and sustainable requirements. Early evaluation of design alternatives using analysis/simulation tools increases the overall quality of the building. These capabilities are reviewed in Chapter 5.

### ***Improved Collaboration Using Integrated Project Delivery***

When the owner uses Integrated Project Delivery (IPD) for project procurement, BIM can be used by the project team from the beginning of the design to improve their understanding of project requirements and to extract cost estimates as the design is developed. This allows design and cost to be better understood and also avoids the use of paper exchange and its associated delays. This is described further in Chapters 4 through 7 and is illustrated in the Sutter Medical Center Castro Valley case study in Chapter 9.

## **1.6.2 Design Benefits (Chapter 5)**

### ***Earlier and More Accurate Visualizations of a Design***

The 3D model generated by the BIM software is designed directly rather than being generated from multiple 2D views. It can be used to visualize the design at any stage of the process with the expectation that it will be dimensionally consistent in every view.

### ***Automatic Low-Level Corrections When Changes Are Made to Design***

If the objects used in the design are controlled by parametric rules that ensure proper alignment, then the 3D model will be free of geometry, alignment, and spatial coordination errors. This reduces the user’s need to manage design changes (see Chapter 2 for further discussion of parametric rules).

### ***Generation of Accurate and Consistent 2D Drawings at Any Stage of the Design***

Accurate and consistent drawings can be extracted for any set of objects or specified view of the project. This significantly reduces the amount of time and

number of errors associated with generating construction drawings for all design disciplines. When changes to the design are required, fully consistent drawings can be generated as soon as the design modifications are entered.

### ***Earlier Collaboration of Multiple Design Disciplines***

BIM technology facilitates simultaneous work by multiple design disciplines. While collaboration with drawings is also possible, it is inherently more difficult and time consuming than working with one or more coordinated 3D models in which change control can be well managed. This shortens the design time and significantly reduces design errors and omissions. It also gives earlier insight into design problems and presents opportunities for a design to be continuously improved. This is much more cost-effective than waiting until a design is nearly complete and then applying value engineering only after the major design decisions have been made.

### ***Easy Verification of Consistency to the Design Intent***

BIM provides earlier 3D visualizations and quantifies the area of spaces and other material quantities, allowing for earlier and more accurate cost estimates. For technical buildings (labs, hospitals, and the like), the design intent is often defined quantitatively, and this allows a building model to be used to check for these requirements. For qualitative requirements (this space should be near another), the 3D model also can support automatic evaluations.

### ***Extraction of Cost Estimates during the Design Stage***

At any stage of the design, BIM technology can extract an accurate bill of quantities and spaces that can be used for cost estimation. In the early stages of a design, cost estimates are based either on formulas that are keyed to significant project quantities, for example, number of parking spaces, square feet of office areas of various types, or unit costs per square foot. As the design progresses, more detailed quantities are available and can be used for more accurate and detailed cost estimates. It is possible to keep all parties aware of the cost implications associated with a given design before it progresses to the level of detailing required of construction bids. At the final stage of design, an estimate based on the quantities for all the objects contained within the model allows for the preparation of a more accurate final cost estimate. As a result, it is possible to make better-informed design decisions regarding costs using BIM rather than a paper-based system. When using BIM for cost estimates, it is clearly desirable to have the general contractor and possibly key trade contractors who will be responsible for building the structure, as part of the project

team. Their knowledge is required for accurate cost estimates and constructability insights during the design process. The use of BIM for cost estimating is a complex one and is discussed in Chapters 4 through 7 and in a number of the case studies presented in Chapter 9.

### ***Improvement of Energy Efficiency and Sustainability***

Linking the building model to energy analysis tools allows evaluation of energy use during the early design phases. This is not practical using traditional 2D tools because of the time required to prepare the relevant input. If applied at all, energy analysis is performed at the end of the 2D design process as a check or a regulatory requirement, thus reducing the opportunities for modifications that could improve the building's energy performance. The capability to link the building model to various types of analysis tools provides many opportunities to improve building quality.

## **1.6.3 Construction and Fabrication Benefits (Chapters 6 and 7)**

### ***Use of Design Model as Basis for Fabricated Components***

If the design model is transferred to a BIM fabrication tool and detailed to the level of fabrication objects (shop model), it will contain an accurate representation of the building objects for fabrication and construction. Because components are already defined in 3D, their automated fabrication using numerical control machinery is facilitated. Such automation is standard practice today in steel fabrication and some sheet metal work. It has been used successfully in precast components, fenestration, and glass fabrication. This allows vendors worldwide to elaborate on the model, to develop details needed for fabrication, and to maintain links that reflect the design intent. This facilitates offsite fabrication and reduces cost and construction time. The accuracy of BIM also allows larger components of the design to be fabricated offsite than would normally be attempted using 2D drawings, due to the likely need for onsite changes (rework) and the inability to predict exact dimensions until other items are constructed in the field. It also allows smaller installation crews, faster installation time, and less onsite storage space.

### ***Quick Reaction to Design Changes***

The impact of a suggested design change can be entered into the building model and changes to the other objects in the design will automatically update. Some updates will be made automatically based on the established parametric rules. Additional cross-system updates can be checked and updated visually or

through clash detection. The consequences of a change can be accurately reflected in the model and all subsequent views of it. In addition, design changes can be resolved more quickly in a BIM system because modifications can be shared, visualized, estimated, and resolved without the use of time-consuming paper transactions. Updating in this manner is extremely error-prone in paper-based systems.

### ***Discovery of Design Errors and Omissions before Construction***

Because the virtual 3D building model is the source for all 2D and 3D drawings, design errors caused by inconsistent 2D drawings are eliminated. In addition, because models from all disciplines can be brought together and compared, multisystem interfaces are easily checked both systematically (for hard and clearance clashes) and visually (for other kinds of errors). Conflicts and constructability problems are identified before they are detected in the field. Coordination among participating designers and contractors is enhanced and errors of omission are significantly reduced. This speeds the construction process, reduces costs, minimizes the likelihood of legal disputes, and provides a smoother process for the entire project team.

### ***Synchronization of Design and Construction Planning***

Construction planning using 4D CAD requires linking a construction plan to the 3D objects in a design, so that it is possible to simulate the construction process and show what the building and site would look like at any point in time. This graphic simulation provides considerable insight into how the building will be constructed day-by-day and reveals sources of potential problems and opportunities for possible improvements (site, crew and equipment, space conflicts, safety problems, and so forth). This type of analysis is not available from paper bid documents. It does, however, provide added benefit if the model includes temporary construction objects such as shoring, scaffolding, cranes, and other major equipment so that these objects can be linked to schedule activities and reflected in the desired construction plan.

### ***Better Implementation of Lean Construction Techniques***

Lean construction techniques require careful coordination between the general contractor and all subs to ensure that work can be performed when the appropriate resources are available onsite. This minimizes wasted effort and reduces the need for onsite material inventories. Because BIM provides an accurate model of the design and the material resources required for each segment of the work, it provides the basis for improved planning and scheduling of subcontractors and helps to ensure just-in-time arrival of people, equipment, and materials.



This reduces cost and allows for better collaboration at the jobsite. The model can also be used with wireless hand-held computers to facilitate material tracking, installation progress, and automated positioning in the field. These benefits are illustrated in the Maryland General Hospital and Crusell Bridge case studies presented in Chapter 9.

### ***Synchronization of Procurement with Design and Construction***

The complete building model provides accurate quantities for all (or most, depending upon the level of 3D modeling) of the materials and objects contained within a design. These quantities, specifications, and properties can be used to procure materials from product vendors and subcontractors (such as precast concrete subs). At the present time (2010), the object definitions for many manufactured products have not yet been developed to make this capability a complete reality. However, when the models have been available (steel members, precast concrete members, some mechanical components, some windows and doors), the results have been very beneficial.

## **1.6.4 Post Construction Benefits (Chapter 4)**

### ***Improved Commissioning and Handover of Facility Information***

During the construction process the general contractor and MEP contractors collect information about installed materials and maintenance information for the systems in the building. This information can be linked to the object in the building model and thus be available for handover to the owner for use in their facility management systems. It also can be used to check that all the systems are working as designed before the building is accepted by the owner. This is illustrated in the Maryland General Hospital case study discussed in Chapter 9.

### ***Better Management and Operation of Facilities***

The building model provides a source of information (graphics and specifications) for all systems used in a building. Previous analyses used to determine mechanical equipment, control systems, and other purchases can be provided to the owner, as a means for verifying the design decisions once the building is in use. This information can be used to check that all systems work properly after the building is completed.

### ***Integration with Facility Operation and Management Systems***

A building model that has been updated with all changes made during construction provides an accurate source of information about the as-built spaces

and systems and provides a useful starting point for managing and operating the building. A building information model supports monitoring of real-time control systems, provides a natural interface for sensors, and remote operating management of facilities. Many of these capabilities have not yet been developed, but BIM provides an ideal platform for their deployment. This is discussed in Chapter 8.

---

## 1.7 WHAT CHALLENGES CAN BE EXPECTED?

Improved processes in each phase of design and construction will reduce the number and severity of problems associated with traditional practices. Intelligent use of BIM, however, will also cause significant changes in the relationships of project participants and the contractual agreements between them. (Traditional contract terms are tailored to paper-based practices.) In addition, earlier collaboration between the architect, contractor, and other design disciplines will be needed, as knowledge provided by specialists is of more use during the design phase. The growing use of IPD project delivery for buildings and other types of structures reflects the strong benefits of integrated teams using BIM and lean construction techniques to manage the design and construction process.

### 1.7.1 Challenges with Collaboration and Teaming

While BIM offers new methods for collaboration, it introduces other issues with respect to the development of effective teams. Determining the methods that will be used to permit adequate sharing of model information by members of the project team is a significant issue. If the architect uses traditional paper-based drawings, then it will be necessary for the contractor (or a third party) to build the model so that it can be used for construction planning, estimating, and coordination. If the architect does create their design using BIM, the model may not have sufficient detail for use for construction or may have object definitions that are inadequate for extracting necessary construction quantities. This may require creating a new model for construction use. If the architectural model is provided, cost and time may be added to the project, but the cost of a model is usually justified by the advantages of using it for construction planning and detailed design by mechanical, plumbing, other subs and fabricators, design change resolution, procurement, and so forth. If the members of the project team use different modeling tools, then tools for moving the models from one environment to another or combining these models are

needed. This can add complexity and introduce potential errors and time to the project. Such problems may be reduced by using IFC standards for exchanging data. Another approach is to use a model server that communicates with all BIM applications through IFC or proprietary standards. These capabilities and issues are reviewed in Chapter 3. A number of the case studies presented in Chapter 9 provide background for this issue.

### **1.7.2 Legal Changes to Documentation Ownership and Production**

Legal concerns are presenting challenges, with respect to who owns the multiple design, fabrication, analysis, and construction datasets, who pays for them, and who is responsible for their accuracy. These issues are being addressed by practitioners through BIM use on projects. As owners learn more about the advantages of BIM, they will likely require a building model to support operations, maintenance, and subsequent renovations. Professional groups, such as the AIA and AGC, are developing guidelines for contractual language to cover issues raised by the use of BIM technology. These are discussed in Chapter 4.

### **1.7.3 Changes in Practice and Use of Information**

The use of BIM will also encourage the integration of construction knowledge earlier in the design process. Integrated design-build firms capable of coordinating all phases of the design and incorporating construction knowledge from the outset will benefit the most. IPD contracting arrangements that require and facilitate good collaboration will provide greater advantages to owners when BIM is used. The most significant change that companies face when implementing BIM technology is intensively using a shared building model during design phases and a coordinated set of building models during construction and fabrication, as the basis of all work processes and for collaboration. This transformation will require time and education, as is true of all significant changes in technology and work processes.

### **1.7.4 Implementation Issues**

Replacing a 2D or 3D CAD environment with a building model system involves far more than acquiring software, training, and upgrading hardware. Effective use of BIM requires that changes be made to almost every aspect of a firm's business (not just doing the same things in a new way). It requires some understanding of BIM technology and related processes and a plan for

implementation before the conversion can begin. A consultant can be very helpful to plan, monitor, and assist in this process. While the specific changes for each firm will depend on their sector(s) of AEC activity, the general steps that need to be considered are similar and include the following:

- Assign top-level management responsibility for developing a BIM adoption plan that covers all aspects of the firm's business and how the proposed changes will impact both internal departments and outside partners and clients.
- Create an internal team of key managers responsible for implementing the plan, with cost, time, and performance budgets to guide their performance.
- Start using the BIM system on one or two smaller (perhaps already completed) projects in parallel with existing technology and produce traditional documents from the building model. This will help reveal where there are deficits in the building objects, in output capabilities, in links to analysis programs, and so forth. It will also allow the firm to develop modeling standards and determine the quality of models and level of detail needed for different uses. It will also provide educational opportunities for leadership staff.
- Use initial results to educate and guide continued adoption of BIM software and additional staff training. Keep senior management apprised of progress, problems, insights, and so forth.
- Extend the use of BIM to new projects and begin working with outside members of the project teams in new collaborative approaches that allow early integration and sharing of knowledge using the building model.
- Continue to integrate BIM capabilities into additional aspects of the firm's functions and reflect these new business processes in contractual documents with clients and business partners.
- Periodically re-plan the BIM implementation process to reflect the benefits and problems observed thus far, and set new goals for performance, time, and cost. Continue to extend BIM-facilitated changes to new locations and functions within the firm.

In Chapters 4 through 7, where specific applications of BIM over the lifecycle of a building are discussed, additional adoption guidelines specific to each party involved in the building process are reviewed.

---

## 1.8 FUTURE OF DESIGNING AND BUILDING WITH BIM (CHAPTER 8)

Chapter 8 describes the authors' views of how BIM technology will evolve and what impacts it is likely to have on the future of the AEC/FM industry and to society at large. There are comments on the near-term future (up to 2015) and the long-term future (up to 2025). We also discuss the kinds of research that will be relevant to support these trends.

It is rather straightforward to anticipate near-term impacts. For the most part, they are extrapolations of current trends. Projections over a longer period are those that to us seem likely, given our knowledge of the AEC/FM industry and BIM technology. Beyond that, it is difficult to make useful projections.

---

## 1.9 CASE STUDIES (CHAPTER 9)

Chapter 9 presents 10 case studies that illustrate how BIM technology and its associated work processes are being used today. These cover the entire range of the building lifecycle, although most focus on the design and construction phases (with extensive illustration of offsite fabrication building models). For the reader who is anxious to “dive right in” and get a first-hand view of BIM, these case studies are a good place to start.

---

## Chapter 1 Discussion Questions

---

1. What is BIM and how does it differ from 3D modeling?
2. What are some of the significant problems associated with the use of 2D CAD, and how do they waste resources and time during both the design and construction phases as compared to BIM-enabled processes?
3. Why has the construction industry not been able to overcome the impact of these problems on field labor productivity, despite the many advances in construction technology?
4. What changes in the design and construction process are needed to enable productive use of BIM technology?
5. How do parametric rules associated with the objects in BIM improve the design and construction process?

6. What are the limitations that can be anticipated with the generic object libraries that come with BIM systems?
7. Why does the design-bid-build business process make it very difficult to achieve the full benefits that BIM can provide during design or construction?
8. How does integrated project delivery differ from the design-build and construction management at risk project procurement methods?
9. What kind of legal problems can be anticipated as a result of using BIM with an integrated project team?
10. What techniques are available for integrating design analysis applications with the building model developed by the architect?
11. How does the use of BIM allow a more sustainable building design?

# CHAPTER 2

---

## BIM Design Tools and Parametric Modeling

---

### 2.0 EXECUTIVE SUMMARY

This chapter provides an overview of the primary technology that distinguishes BIM design applications from earlier generation CAD systems. Object-based parametric modeling was originally developed in the 1980s for manufacturing. It does not represent objects with fixed geometry and properties. Rather, it represents objects by parameters and rules that determine the geometry as well as some nongeometric properties and features. The parameters and rules can be expressions that relate to other objects, thus allowing the objects to automatically update according to user control or changing contexts. Custom parametric objects allow for the modeling of complex geometries, which were previously not possible or simply impractical. In other industries, companies use parametric modeling to develop their own object representations and to reflect corporate knowledge and best practices. In architecture, BIM software companies have predefined a set of base building object classes for users, which may be added to, modified, or extended. An object class allows for the creation of any number of object instances, with forms that vary, depending on the current parameters

and relationships with other objects. How an object updates itself as its context changes is called its *behavior*. The system-provided object classes predefine what is a wall, slab, or roof in terms of how they interact with other objects. Companies should have the capability of developing user-defined parametric objects—both new ones and extensions of existing ones—and corporate object libraries for customized features and to establish their own best practices. Object attributes are needed to interface with analyses, cost estimations, and other applications, but these attributes must first be defined by the firm or user.

Architectural BIM design applications let users mix 3D modeled objects with 2D drawn sections, allowing users to determine the level of 3D detailing while still being able to produce complete drawings. Objects drawn in 2D are not included in bills of material, in analyses, and other BIM-enabled applications, however. Fabrication-level BIM design applications, alternatively, typically represent every object fully in 3D. The level of 3D modeling is a major variable within different BIM practices.

Current BIM design applications include services to carry out specific tasks as a *tool*, but they also provide a *platform* for managing the data within a model for different uses. Some incorporate the ability to manage data in different models—a BIM *environment*. Any BIM application addresses one or more of these types of services. At the tool level, they vary in the sophistication of their predefined base objects; in the ease with which users can define new object classes; in the methods of updating objects; in ease of use; in the types of surfaces that can be used; in the capabilities for drawing generation; in their ability to handle large numbers of objects. At the platform level, they vary in the ability to manage large or very detailed projects, their interfaces with other BIM tool software, their interface consistency for using multiple tools, in their extensibility, in the external libraries that can be used and the data they carry to allow management, and their ability to support collaboration.

This chapter provides an overall review of the major BIM model generation technology and the tools and functional distinctions that can be used for assessing and selecting among them.

---

## 2.1 THE EVOLUTION TO OBJECT-BASED PARAMETRIC MODELING

A good craftsman knows his tools, whether the tools involve automation or not. This chapter begins by providing a strong conceptual framework for understanding the capabilities that make up BIM design applications.

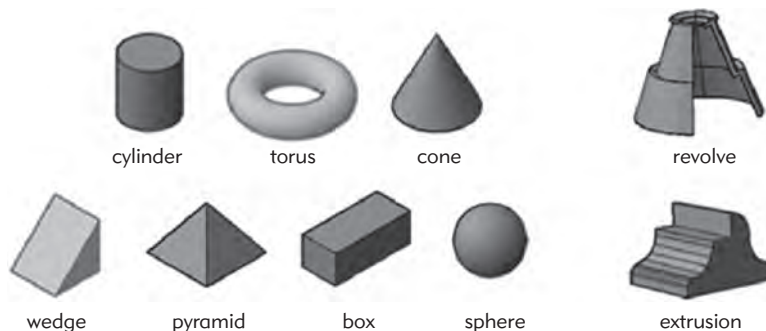


The current generation of building modeling tools is the outgrowth and four decades of research and development on computer tools for interactive 3D design, culminating in object-based parametric modeling. One way of understanding the current capabilities of modern BIM design applications is by reviewing their incremental evolution historically. Below is a short history.

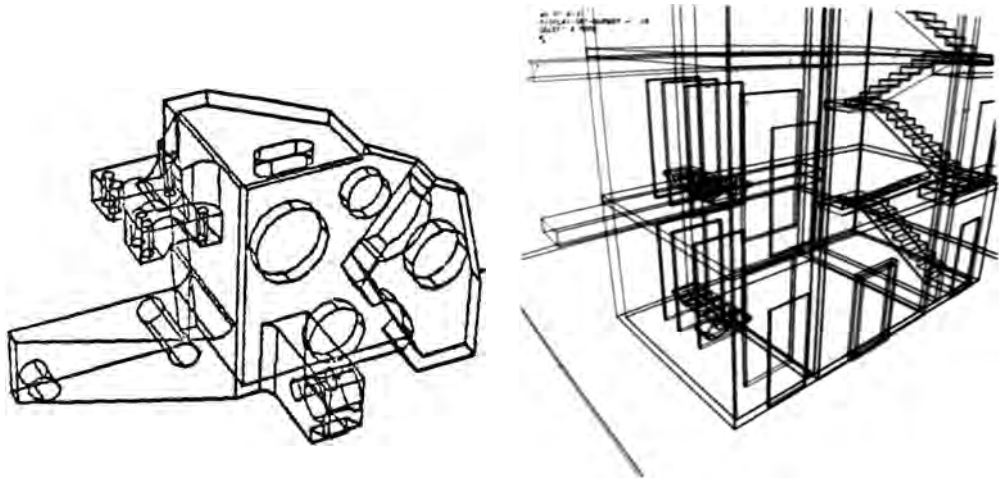
### 2.1.1 Early 3D Modeling

Since the 1960s, modeling of 3D geometry has been an important research area. Development of new 3D representations had many potential uses, including movies, architectural and engineering design, and games. The ability to represent compositions of polyhedral forms for viewing was first developed in the late 1960s and later led to the first computer-graphics film, *Tron* (in 1987). These initial polyhedral forms could be composed into an image with a limited set of parameterized and scalable shapes but designing requires the ability to easily edit and modify complex shapes. In 1973, a major step toward this goal was realized. The ability to create and edit arbitrary 3D solid, volume-enclosing shapes was developed separately by three groups: Ian Braid at Cambridge University, Bruce Baumgart at Stanford, and Ari Requicha and Herb Voelcker at the University of Rochester (Eastman 1999; Chapter 2). Known as *solid modeling*, these efforts produced the first generation of practical 3D modeling design tools.

Initially, two forms of solid modeling were developed and competed for supremacy. The boundary representation approach (B-rep) represented shapes as a closed, oriented set of bounded surfaces. A shape was a set of these bounded surfaces that satisfied a defined set of volume-enclosing criteria, regarding connectedness, orientation, and surface continuity among others (Requicha 1980). Computational functions were developed to allow creation of these shapes with variable dimensions, including parameterized boxes, cones, spheres, pyramids, and the like, as shown in Figure 2-1 (left). Also provided were swept shapes: extrusions and revolves defined as a profile and a sweep axis—straight or around an axis of rotation (Figure 2-1 (right)). Each of these operations



**FIGURE 2-1**  
A set of functions that generate regular shapes, including sweeps.



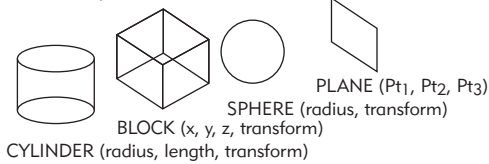
**FIGURE 2-2** One of the first complex mechanical parts generated using B-reps and the Boolean operations (Braid 1973) and an early solid modeler representation of a building service core (Eastman 1976).

created a well-formed B-rep shape with specified dimensions. Editing operations placed these shapes in relation to one another, possibly overlapping. Overlapped shapes could be combined by the operations of spatial union, intersection, and subtraction—called the Boolean operations—on pairs or multiple polyhedral shapes. These operations allowed the user to interactively generate quite complex shapes, such as the examples shown in Figure 2-2 from Braid’s thesis or Eastman’s early office building. The editing operations had to output shapes that were also well-formed B-reps, allowing operations to be concatenated. The shape creation and editing systems provided by combining primitive shapes and the Boolean operators allowed generation of a set of surfaces that together were guaranteed to enclose a user-defined volumetric shape. Shape editing on the computer began.

In the alternative approach, Constructive Solid Geometry (CSG) represented a shape as a set of functions that define the primitive polyhedra like those defined in Figure 2-3 (left), similar to those for B-rep. These functions are combined in algebraic expressions, also using the Boolean operations, shown in Figure 2-3 (right). However, CSG relied on diverse methods for assessing the final shape defined as an algebraic expression. For example, it might be drawn on a display, but no set of bounded surfaces was generated. An example is shown in Figure 2-4. The textual commands define a set of primitives for representing a small house. The last line above the figure composes the shapes using the Boolean operations. The result is the simplest of building shapes: a single shape hollowed with a single floor space with a gable roof and door opening. The placed but not evaluated shapes are shown on the right. The main difference between CSG

**THE CSG MODEL:**

A set of primitives of the form:



A set of operators:

- UNION (S<sub>1</sub>, S<sub>2</sub>, S<sub>3</sub>,.....)
- INTERSECT (S<sub>1</sub>, S<sub>2</sub>)
- DIFFERENCE (S<sub>1</sub>, S<sub>2</sub>)
- CHAMFER (edge, depth)

**FIGURE 2-3**

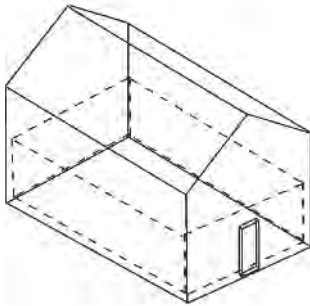
A set of primitive shapes and operators for Constructive Solid Geometry. Each shape's parameters consist of those defining the shape and then placing it in 3D space.

```
BuildingMass := BLOCK(35.0,20.0,25.0,(0,0,0,0,0,));
Space := BLOCK(34.0,19.0,8.0,(0.5,0.5,0,1.0,0,0));
Door := BLOCK(4.0,3.0,7.0,(33.0,6.0,1.0,1.0,0,0));
Roofplane1 := PLANE((0.0,0.0,18.0),(35.0,0.0,18.0),(35.0,10.0,25.0));
Roofplane2 := PLANE((35.0,10.0,25.0),(35.0,20.0,18.0),(0.0,20.0,18.0));
Building := (((BuildingMass - Space) _ Door) - Roofplane1) - Roofplane2;
```

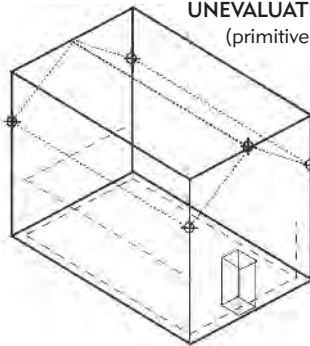
**FIGURE 2-4**

The definitions of a set of primitive shapes and their composition into a simple building. The building is then edited.

**EVALUATED MODEL:**

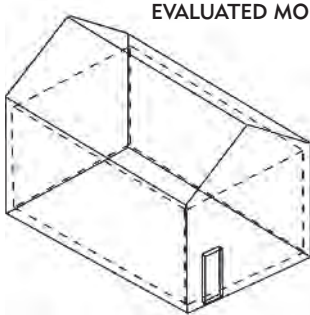


**UNEVALUATED MODEL:  
(primitives displayed):**

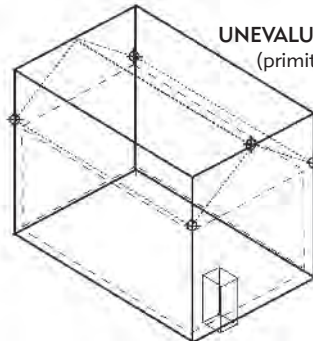


```
Space := BLOCK(34.0,19.0,14.0,(0.5,0.5,0,1.0,0,0));
Door := BLOCK(4.0,3.0,7.0,(33.0,6.0,1.0,1.0,0,0));
```

**EVALUATED MODEL:**



**UNEVALUATED MODEL:  
(primitives displayed):**



and B-rep is that CSG stored an algebraic formula to define a shape, while B-rep stored the results of the definition as a set of operations and object arguments. The differences are significant. In CSG, elements can be edited and regenerated on demand. Notice that in Figure 2-4, all locations and shapes parameters can

be edited via the shape parameters in the CSG expressions. This method of describing a shape—as text strings—was very compact, but took several seconds to compute the shape on desktop machines of that era. The B-rep, on the other hand, was excellent for direct interaction, for computing mass properties, rendering and animation, and for checking spatial conflicts.

Initially, these two methods competed to determine which was the better approach. It soon was recognized that the methods should be combined, allowing for editing within the CSG tree (sometimes called the *unevaluated shape*). By using the B-rep for display and interaction to edit a shape, compositions of shapes could be made into more complex shapes. The B-rep was called the *evaluated shape*. Today, all parametric modeling tools and all building models incorporate both representations, one CSG-like for editing, and the B-rep for visualizing, measuring, clash detection, and other nonediting uses. First-generation tools supported 3D faceted and cylindrical object modeling with associated attributes, which allowed objects to be composed into engineering assemblies, such as engines, process plants, or buildings (Eastman 1975; Requicha 1980). This merged approach to modeling was a critical precursor to modern parametric modeling.

The value of associating materials and other properties with the shapes was quickly recognized in these early systems. These could be used for preparation of structural analyses or for determining volumes, dead loads, and bills of material. Objects with material lead to situations where a shape made of one material was combined by the Boolean operation with a shape of another material. What is the appropriate interpretation? While Subtractions have a clear intuitive meaning (walls in windows and holes in steel plate), Intersections and Unions of shapes with different material do not.

This conceptually was a problem because both objects were considered as having the same status—as individual objects. These conundrums led to the recognition that a major use of Boolean operations was to embed “features” into a primary shape, such as connections in precast pieces, reliefs, or bullnose in concrete (some added and others subtracted). An object that is a feature to be combined with the main object is placed relatively to the main object; the feature later can be named, referenced, and edited. The material of the main object applies to any changes in volume. Feature-based design is a major subfield of parametric modeling (Shah and Mantyla 1995) and was another important incremental step in the development of modern parametric design tools. Window and door openings with fillers are intuitive examples of features within a wall.

Building modeling based on 3D solid modeling was first developed in the late 1970s and early 1980s. CAD systems, such as RUCAPS (which evolved

into Sonata), TriCad, Calma, GDS (Day 2002), and university research-based systems at Carnegie-Mellon University and the University of Michigan developed their basic capabilities. (For one detailed history of the development of CAD technology see <http://mbinfo.mbdesign.net/CAD-History.htm>.) This work was carried out concurrently by teams in mechanical, aerospace, building and electrical product design, sharing concepts and techniques of product modeling and integrated analysis and simulation.

Solid modeling CAD systems were functionally powerful but often overwhelmed the available computing power. Some production issues in building, such as drawing and report generation, were not well developed. Also, designing 3D objects was conceptually foreign for most designers, who were more comfortable working in 2D. The systems were also expensive, costing upward of \$35,000 per seat. The manufacturing and aerospace industries saw the huge potential benefits in terms of integrated analysis capabilities, reduction of errors, and the move toward factory automation. They worked with CAD companies to resolve the technology's early shortcomings and led efforts to develop new capabilities. Most of the building industry did not recognize these benefits. Instead, they adopted architectural drawing editors, such as AutoCAD®, Microstation®, and MiniCAD® that augmented the then-current methods of working and supported the digital generation of conventional 2D design and construction documents.

Another step in the evolution from CAD to parametric modeling was the recognition that multiple shapes could share parameters. For example, the boundaries of a wall are defined by the floor planes, wall, and ceiling surfaces that bound it; how objects are connected partially determines their shape in any layout. If a single wall is moved, all those that abut it should update as well. That is, changes propagate according to their connectivity. In other cases, geometry is not defined by related objects' shapes, but rather globally. Grids are one example, which have long been used to define structural frames. The grid intersection points provide dimensional parameters for placing and orientating shape location or parameters. Move one grid line and the shapes defined relatively to the associated grid points must also update. Global parameters and equations can be used locally too. The example for a portion of a façade shown in Figure 2–6 provides an example of this kind of parametric rule.

Initially, these capabilities for stairs or walls were built into object-generating functions, for example, where the parameters for a stairway were defined: a location, and stair riser, tread and width parameters given, and the stair assembly constructed. These types of capabilities allowed the layout of stairs in Architectural Desktop, and the development of assembly operations in AutoCAD 3D, for example. But this is not yet full parametric modeling.

Later in the development of 3D modeling, the parameters defining shapes could be automatically reevaluated and the shape rebuilt, first on-demand under control by the users. Then the software was given flags to mark what was modified, so only the changed parts were rebuilt. Because one change could propagate to other objects, the development of assemblies with complex interactions led to the need to the development of a “resolver” capability that analyzed the changes and chose the most efficient order to update them. The ability to support such automatic updates is the current state-of-art in BIM and parametric modeling.

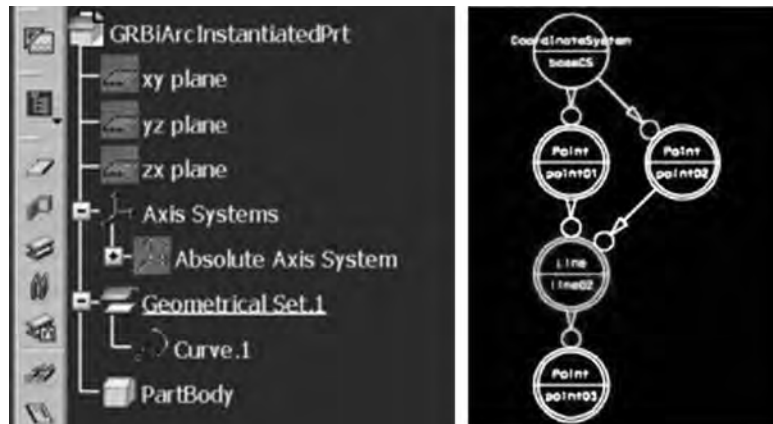
In general, the internal structure of an object instance defined within a parametric modeling system is a directed graph, where the nodes are object classes with parameters or operations that construct or modify an object instance; links in the graph indicate relations between nodes. Some systems offer the option of making the parametric graph visible for editing, as shown in Figure 2–5. Modern parametric object modeling systems internally mark where edits are made and only regenerate affected parts of the model’s graph, minimizing the update sequence.

The range of rules that can be embedded in a parametric graph determines the generality of the system. Parametric object families are defined using parameters involving distances, angles, and rules, such as *attached to*, *parallel to*, and *distance from*. Most allow “if-then” conditions. The definition of object classes is a complex undertaking, embedding knowledge about how they should behave in different contexts. If-then conditions can replace one design feature with another, based on the test result or some condition. These are used in structural detailing, for example, to select the desired connection type, depending upon loads and the members being connected. Examples are provided in Chapter 5.

Several BIM design applications support parametric relations to complex curves and surfaces, such as splines and nonuniform B-splines (NURBS).

**FIGURE 2-5**

The parametric tree representation in some BIM applications.



These tools allow complex curved shapes to be defined and controlled similarly to other types of geometry. Several major BIM design applications on the market have not included these capabilities, possibly for performance or reliability reasons.

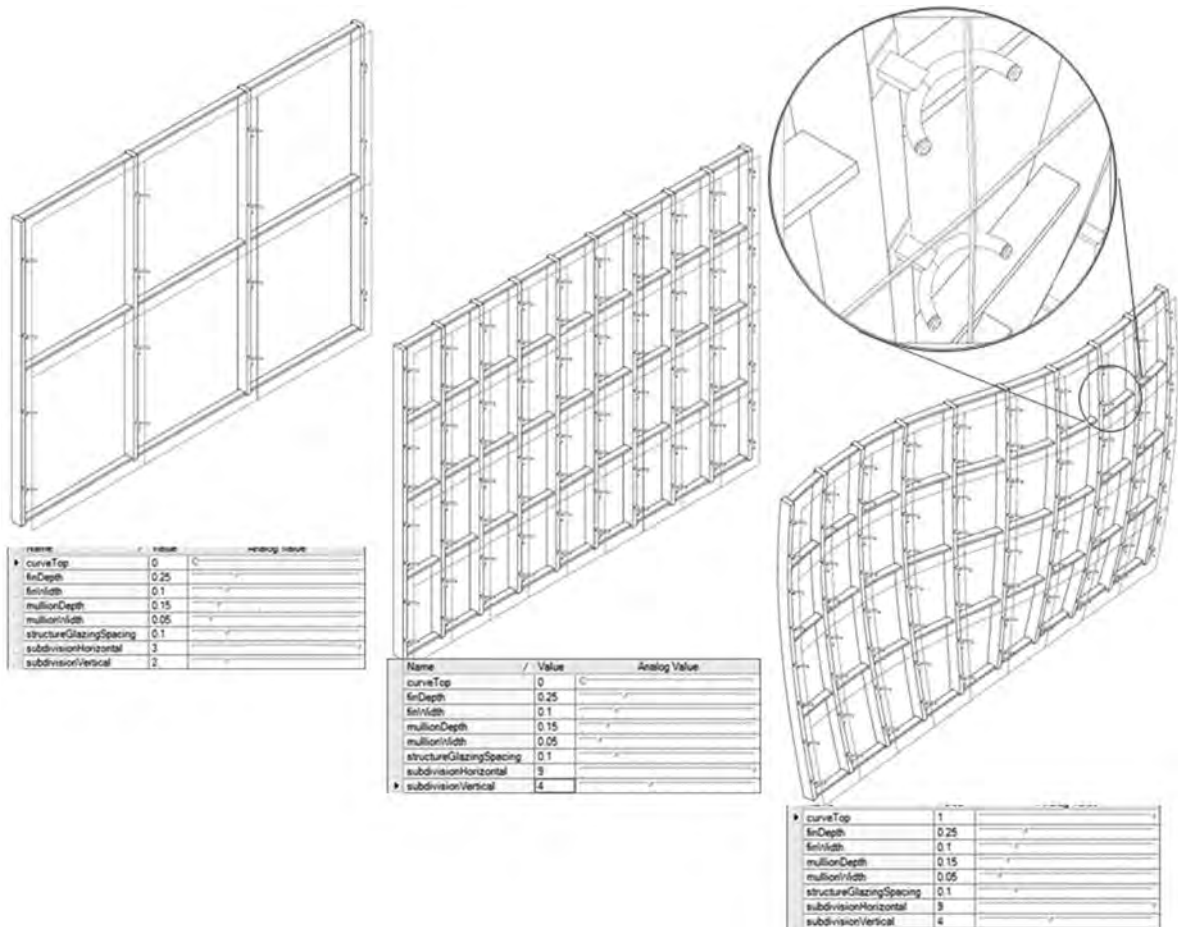
The definition of parametric objects also provides guidelines for their later dimensioning in drawings. If windows are placed in a wall according to the offset from the wall-end to the center of the window, the default dimensioning will be done this way in later drawings.

In summary, there is an important but varied set of parametric capabilities, some of which are not supported by all BIM design tools. These include:

- Generality of parametric relations, ideally supporting full algebraic and trigonometric capabilities
- Support for condition branching and writing rules that can associate difference features to an object instance
- Providing links between objects and being able to make these attachments freely, such as a wall whose base is a slab, ramp, or stair
- Using global or external parameters to control the layout or selection of objects
- Ability to extend existing parametric object classes, so that the existing object class can address new structures and behavior not provided originally

Parametric object modeling provides a powerful way to create and edit geometry. Without it, model generation and design would be extremely cumbersome and error-prone, as was found with disappointment by the mechanical engineering community after the initial development of solid modeling. Designing a building that contains a hundred thousand or more objects would be impractical without a system that allows for effective low-level automatic design editing.

Figure 2–6, developed using Generative Components by Bentley, is an example custom parametric assembly. The example shows a curtain wall model whose main geometric attributes are defined and controlled parametrically. The model is defined by a structure of center lines dependent on few control points. Different layers of components are propagated on and around the center lines, adapting to global changes on the overall shape and subdivisions of the curtain wall. The parametric models were designed to allow a range of variations that were defined by the person defining the parametric model. It allows the different alternatives shown to be generated in close to real time.



**FIGURE 2-6** A partial assembly of a freeform façade. The mullion partitioning and dimensions are defined in the parameter table, while the curvature is defined by a curved surface behind it. The surface drives automatic adjustment of the mullion profiles, glazing panelization, and bracket rotation. The faceted glazing panels are connected by brackets as shown in the blowup. This wall model and its variations were generated using Generative Components® by Andres Cavieres.

### 2.1.2 Object-Based Parametric Modeling of Buildings

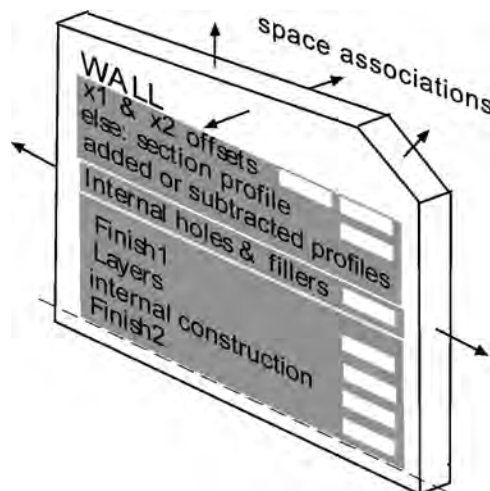
The current generation of BIM architectural design tools, including Autodesk Revit® Architecture and Structure, Bentley Architecture and its associated set of products, Graphisoft ArchiCAD®, Gehry Technology's Digital Project™, Nematschek Vectorworks®, as well as fabrication-level BIM design applications, such as Tekla Structures, SDS/2, and Structureworks, all grew out of the object-based parametric modeling capabilities developed and refined first for mechanical systems design. Particular mention should be made of Parametric Technologies Corporation® (PTC). In the 1980s, PTC led efforts to define shape



instances and other properties defined and controlled according to a hierarchy of parameters at the assembly and at an individual object level. The shapes could be 2D or 3D.

In parametric design, instead of designing an instance of a building element like a particular wall or door, a designer first defines an element class or family which defines some mixture of fixed and parametric geometry, a set of relations and rules to control the parameters by which element instances can be generated. The shape from a model family will vary according to its context. Objects and their faces can be defined using relations involving distances, angles, and rules like *attached to*, *parallel to*, and *offset from*. These relations allow each instance of an element class to vary according to its own parameter settings and the contextual conditions of related objects (such as the walls a given element butts into). Alternatively, the rules can be defined as requirements that the design must satisfy, such as the minimum thickness of a wall or concrete covering of rebar, allowing the designer to make changes while the rules check and update details to keep the design element satisfying the rules and warning the user if the rules cannot be met. Object-based parametric modeling supports both interpretations.

While in traditional 3D CAD every aspect of an element's geometry must be edited manually by users, the shape and assembly geometry in a parametric modeler automatically adjusts to changes in context and to high-level user controls. In this sense, it edits itself, based on the rules used to define it. An example wall class, including its shape attributes and relations, is shown in Figure 2–7. Arrows represent relations with adjoining objects. Figure 2–7 defines a wall family or class, because it is capable of generating many instances of its



**FIGURE 2-7**  
Conceptual structure of a wall-object family, with various edges associated with bounding surfaces.

class in different locations and with varied parameters. Wall families can vary greatly in terms of the geometry they can support, to their internal compositional structure, and how the wall can be connected to other parts of the building. These are determined by how the wall class designers set up the wall's parameters and the parameters assigned and objects related to a wall instance. Some BIM design applications incorporate different wall classes to allow more of these distinctions to be addressed (but don't try to convert one type of wall to another—it cannot be done).

For most walls, the thickness is defined explicitly as two offsets from the wall control line, based on a nominal thickness or the type of construction. The offsets may be derived from an ordered list of layers that show the core, insulation, cladding, interior finish, and other significant properties of the wall object. Some systems support tapered walls, applying a vertical profile to the section. The wall's elevation shape is defined by (usually) one or more base floor planes; its top face may be an explicit height or related to a specified set of adjacent planes (as shown in Figure 2–7). The wall ends are defined by the wall's intersection, having either a fixed endpoint (freestanding) or associations with other walls or columns. Special operations are required if some layers protrude beyond the floor level, such as for covering the foundation with the wall finish. The control line of the wall (shown along the bottom in Figure 2–7) has a start and end point, so the wall does too. A wall is associated with all the object instances that bound it and the multiple spaces it separates.

Wall construction such as stud layouts can be assigned to one or more layers in the wall (multiple when providing acoustical or thermal breaks). Door or window openings have placement points defined by a length along the wall from one of its endpoints to a side or to the center of the opening with its required parameters. The construction and openings are located in the coordinate system of the wall, so they all move as a unit. A wall will adjust its ends by moving, growing, or shrinking as the floor-plan layout changes, with windows and doors also moving and updating. Any time one or more surfaces of the bounding wall changes, the wall automatically updates to retain the intent of its original layout. Constructions should, but may not, update themselves when the length of a wall changes.

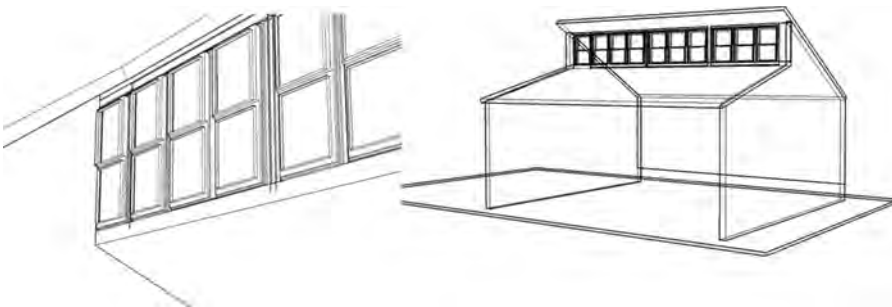
Walls are ubiquitous and complex. A well-crafted definition of a parametric wall must address a range of special conditions. These might include:

- The door and window locations must not overlap each other or extend beyond the wall boundaries or where a wall tee intersection blocks an opening. Typically, a warning is displayed if these conditions arise.

- A wall control line may be straight or curved, allowing the wall to take varied shapes in plan.
- A wall may intersect floor, ceiling, other walls, stairs, ramps, columns, beams, and other building elements, any of which are made up of multiple surfaces and result in a more complex wall shape.
- Walls made up of mixed types of construction and finishes may change within segments of a wall.

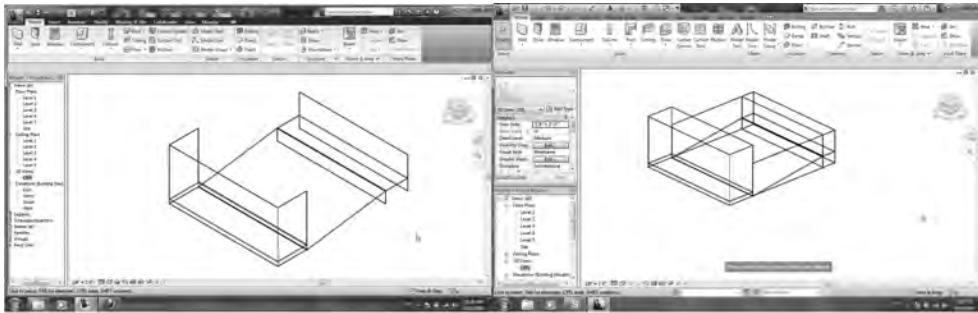
As these conditions suggest, significant care must be taken to define even a generic wall. It is common for a parametric building element class to have over 100 low-level rules for its definition and an extensible set of properties. These conditions show how architectural or building design is a collaboration between the BIM object class modeler, who defines the system of behaviors of BIM elements, and the architectural or building user, who generates designs within the products' rule set (or building semantics). It also explains why users may encounter problems with unusual wall layouts—because they are not covered by the built-in rules. For example, a clerestory wall and the windows set within it are shown in Figure 2–8. In this case, the wall must be placed on a nonhorizontal floor plane. Also, the walls that trim the clerestory wall ends are not on the same base-plane as the wall being trimmed. BIM modeling tools have trouble dealing with such combinations of conditions.

In Figure 2–9, we present a sequence of editing operations for the schematic design of a theater. The designer explicitly defines the bounding relations of walls, including end-wall butting and floor connections, in order to facilitate later easy editing. When set up appropriately, changes such as the ones shown in Figures 2–9a to 9g become simple and it is possible to make quick edits and updates. Notice that these parametric modeling capabilities go far beyond those offered in previous CSG-based CAD systems. They support automatic updating of a layout and the preservation of relations set by the designer. These tools can be extremely productive.

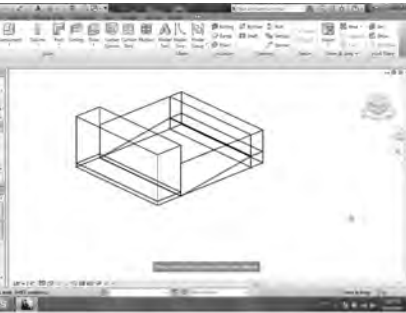


**FIGURE 2–8**

A clerestory wall in a ceiling that has different parametric modeling requirements than most walls.



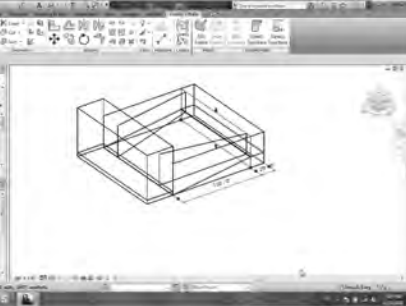
2-9a



2-9b



2-9c



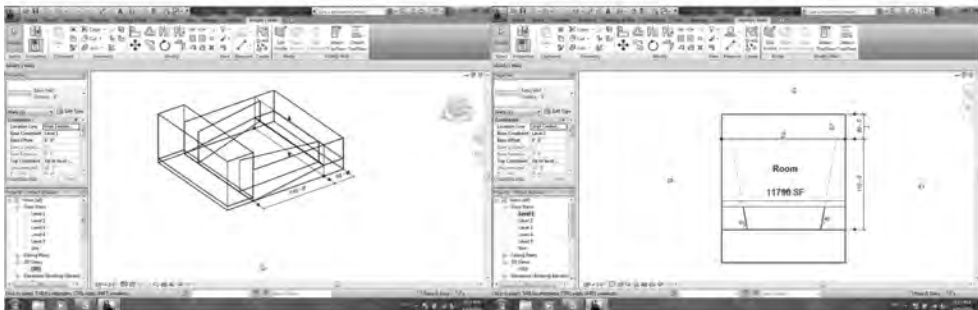
2-9d



2-9e



2-9f



2-9g



2-9h

**FIGURE 2-9** An example of parametric modeling: A theater is initiated with (a) a raised lobby at the rear, sloping house floor and raised stage at the front; (b) the enclosing walls and roof are added; (c) angled side walls are added, but do not naturally attach to the sloped house floor; (d) these are aligned to the sloped floor; (e) rules are added to align the sloping wall with the lobby floor; (f) the areas of the house are used for quick estimates of seating; (g) the lobby depth is increased to provide more space, automatically changing the slope of the house floor and the bottom of the side walls; (h) the house space area is reviewed to consider seating implications.

### 2.1.3 Degrees of Parametric Modeling

There are many detailed differences between the domain-specific parametric modeling tools used in BIM and those used in other industries. Also, there are several different types of BIM design applications, with different object classes for dealing with different building systems. Buildings are composed of a very large number of relatively simple parts. Each building system has typical building rules and relations that are more predictable than for general manufactured objects. However, the amount of information in even a medium-sized building at construction-level detail can cause performance problems in even the most high-end personal workstations. Another difference is that there is a broad set of standard practices and codes in construction that can be readily adapted and embedded to define object behaviors. Also, BIM design applications require drawing production using architectural conventions, in contrast to mechanical systems, which often do not support drawing, or use simpler orthographic drawing conventions. These differences have resulted in only a few general-purpose parametric modeling tools being adapted and used for building information modeling. However, this is a business option for many manufacturing-oriented systems.

As described in the previous history, several different technologies are combined to provide a modern parametric modeling system.

1. At the simplest level is the definition of complex shapes or assemblies defined by a few parameters. This is often called parametric solid modeling. Editing consists of making changes to the parameters and regenerating the piece or layout when called by the user. AutoCAD is an example CAD platform of this type upon which many BIM tools have been developed.
2. An incremental improvement is the definition of assembly modeling that automatically updates when any shape's parameters are changed, with updates carried out in a fixed order of the whole layout. This can be called parametric assemblies. This was the recent status of Architectural Desktop.
3. A major improvement allows the parameters defining one shape to be linked through rules to the parameters of another shape. Because shapes may be related in different ways, the system has to automatically determine the update sequence. This is considered full parametric modeling, or Parametric Object Modeling (Anderl and Mendgen, 1996).

---

## 2.2 PARAMETRIC MODELING OF BUILDINGS

In manufacturing, parametric modeling has been used by companies to embed design, engineering, and manufacturing rules within the parametric models of

their products. For example, when Boeing undertook the design of the 777, they defined the rules by which their airplane interiors were to be defined, for looks, fabrication, and assembly. They fine-tuned the outside shape for aerodynamic performance through many hundreds of airflow simulations—called Computational Fluid Dynamics (CFD)—linked to allow for many alternative shapes and parametric adjustments. They preassembled the airplane virtually in order to eliminate more than 6,000 change requests and to achieve a 90 percent reduction in spatial rework. It is estimated that Boeing invested more than \$1 billion dollars to purchase and set up their parametric modeling system for the 777 family of planes. A good overview of the Boeing effort, its strengths and shortcomings, is available at the CalTech Website (1997) listed in the Bibliography.

In a similar way, the John Deere Company, working with LMS of Belgium, defined how they wanted their tractors to be constructed. Various models were developed based on John Deere's design-for-manufacturing (DfM) rules ([www.lmsintl.com/virtuallab](http://www.lmsintl.com/virtuallab)). Using parametric modeling, companies usually define how their object families are to be designed and structured, how they can be varied parametrically and related into assemblies based on function, production, assembly, and other criteria. In these cases, the companies are embedding corporate knowledge based on past manual efforts on design, production, assembly, and maintenance concerning what works and what does not. This is one aspect of how to capture, reuse, and extend corporate expertise. This is the standard practice in large aerospace, manufacturing, and electronics companies.

### 2.2.1 Parametric Design

Conceptually, building information modeling tools are different flavors of object-based parametric modeling systems. They are different because they have their own predefined set of object classes, each having possibly different behaviors programmed within them, as outlined above. A fairly complete listing of the predefined object families provided by major BIM architectural design tools is given in Table 2–1 (as of mid-2010). These sets of predefined object families are those that can be readily applied to building designs in each system.

In addition to vendor-provided object families, a number of Web sites make additional object families available for downloading and use. These are the modern equivalent of drafting block libraries that were available for 2D drafting systems—but, of course, they are much more useful and powerful. They include, for example, furniture, plumbing and electrical equipment, and proprietary fasteners for concrete fabrication. They are available both as generic objects and as models of specific products. They are discussed in Chapter 5, Section 5.4.2, where some of the sites are listed.

The built-in behaviors of BIM objects identify how they can be linked into assemblies and automatically adjust their own design when their context with

other objects change. Examples are walls and their updates when other walls or ceilings change, as shown in Figure 2–9. Another is how spaces update in most systems when their bounding walls change. These object classes also define what features can be associated with building objects. A connection is a basic feature in a fabrication-level BIM application. Can a connection be made in the face of a wall (a feature often encountered in precast concrete)? Because of such possible limitations, it is important that users can extend the given base object classes or create new ones to address issues not originally anticipated by the BIM software developers.

The base objects that are built into the most popular BIM design software are shown in Table 2–1. The parametric objects supported in BIM construction tools are listed in Table 2–2. These tables only list objects that come with the BIM

**Table 2–1** Built-In Base Object Families in Major BIM Architectural Design Applications

<b>BIM DESIGN Tool</b>					
<b>Base Objects</b>	<b>ArchiCAD v14</b>	<b>Bentley Architecture v8.i</b>	<b>Revit Architecture v2011</b>	<b>Vectorworks 2010</b>	<b>Digital Project V1, R4, SP 7</b>
Site model	Mesh tool, site objects	(Contoured model)	(Topo surface) & site objects	In Landmark product	Surface model
Space definition	■ (manual)	■ (manual)	■ (automatic)	■ (manual)	■ (automatic)
Wall	■	■	■	■	■
Column	■	■	■	■	■
Roof	■	■	■	■	
Stair	■	■	■	■	■
Slab	■	■	■	■	■
Zone	Zone	Zone	Area	Area	
Beam	■	■	■	■	■
Unique Objects for Each Platform	Cast-in-place, precast concrete, steel, masonry, thermal & moisture, furnishings, equipment, conveying systems, plumbing, HVAC, electrical, site	Curtain walls, truss, plumbing, toilet accessories, handrails, shelving, shaft	Area, component, ceiling curtain system, curtain grid, mullion, truss, beam system foundation items, ramp, railing	Window wall, mech. equipment, kitchen cabinet, railing, elevator, escalator, rail, pipe fittings, duct fittings, mechanical equipment	Pipe, duct, mech. equipment, railings, opening, opening profile construction equipment

**Table 2–2** Predefined Objects in Some Common Construction/Fabrication BIM Tools

<b>BIM Detailing Tool</b>					
<b>Base Objects</b>	<b>Tekla v16.1</b>	<b>Design Data SDS/2</b>	<b>Revit MEP v9.1 (Objects)</b>	<b>AutoCAD MEP (Objects &amp; Blocks)</b>	<b>Bentley Mechanical and Electrical v8.i</b>
<b>Base Objects</b>	Part Beam Polybeam Contour plate Welds Weld Logical weld Polygonal Weld Loads Load line Load area Load point Bolts Bolt array Bolt circle Bolt list Reinforcing Rebar strand Rebar mesh Single rebar Rebar group Rebar splice Task type	Grid lines Member Material Connection Bolts Holes Welds Loads Moments	Air terminals Communication devices Cable tray Connectors Conduit Connectors Duct fittings Duct accessories Duct connectors Electrical devices Elect equipment Elect. fixtures Fire alarm dev. Flex duct Flex pipes HVAC zones Lighting devices Lighting fixtures Mech. equipment Nurse call devices Pipe accessories Pipe connectors Plumbing fixtures Space	Cable tray Cable tray fitting Conduit Conduit fitting Device Duct Duct custom fitting Duct fitting Duct flex Engr. space Hanger Multiview part Panel Pipe Pipe custom fitting Pipe fitting Plumbing line Schematic line Pipe flex Plumbing fitting Wire Space	<b>Mechanical:</b> Ducts Pipes Connectors Valves Grills & Diffusers Dampers Filters Silencers <b>Electrical:</b> Cable trays Power distribution – Lighting – Fire alarm – Emergency Lighting Telecommunications – Information technologies – Security – Public address – Lighting protection – Video – EIB Spaces Engineering zones
<b>Knowledge Functionality</b>	<input type="checkbox"/> Clash detection <input type="checkbox"/> 4D simulation <input type="checkbox"/> Work packet coordination <input type="checkbox"/> Quantity take-offs <input type="checkbox"/> Supports automated fabrication <input type="checkbox"/> Interfaces to multiple structural analysis tools	<input type="checkbox"/> Automatic connection design <input type="checkbox"/> Erectability checks <input type="checkbox"/> Quantity take-offs <input type="checkbox"/> Supports automated fabrication <input type="checkbox"/> Interfaces to multiple structural analysis tools	<input type="checkbox"/> Synchronized schedules <input type="checkbox"/> Duct and pipe sizing/pressure calculations <input type="checkbox"/> HVAC and electrical system design <input type="checkbox"/> Conduit and cable tray modeling (gbXML) <input type="checkbox"/> interface for use with Autodesk® Ecotect® Analysis software and Autodesk® Green Building Studio® Web-based analysis and IES	<input type="checkbox"/> Synchronized schedules <input type="checkbox"/> Interfaces for fabrication <input type="checkbox"/> Automatic duct sizing based on space demands <input type="checkbox"/> Electrical circuit manager <input type="checkbox"/> Interference checking <input type="checkbox"/> Radiator sizing and number <input type="checkbox"/> Plumbing pipe sizing	<input type="checkbox"/> Exchange data with energy analysis programs such as EDSSL/TAS, ECOTECT, Trace 700, Carrier HAP, Green Building Studio, etc. <input type="checkbox"/> Feeder and branch circuiting <input type="checkbox"/> Automated circuiting and labeling <input type="checkbox"/> Online design checks for circuit load, length, and number of devices <input type="checkbox"/> Automated fixture arrangement <input type="checkbox"/> Bidirectional links to third-party lighting analysis programs: – Lumen Designer – DIALux – Relux



application, not the externally available objects available from other sources. Some companies have tried to include as broad a range of desired objects as possible. Others have limited their built-in objects to those with specific parametric behavior that is related to other objects in the addressed market sector.

Each of the BIM design applications also includes other objects that are used to modify primary building shell objects. They include openings and joints in walls and slabs, openings for skylights and dormers in roofs, connectors for beams, columns, and other structural objects.

A distinction exists between those objects that interact with other objects, such as walls, beams, slabs, columns—that have complex behavior that are the core of a BIM design tool, and other objects that do not need to have parametric behaviors, such as bathroom fixtures, door and window products with fixed sizes, and other objects that do not vary with their context. This second class, sometimes called building object models, are more easily created and made available in external libraries because they do not depend heavily on the dynamic parameters of other objects. This second class is widely available on building object Web sites and the libraries supporting this architecture are reviewed in Chapter 5; fabrication-level building objects are also discussed in Chapter 7. The third class of objects is the commercial products that are custom-made to their context. These include curtain wall systems, complex ceiling systems, cabinetry, railings, and other architectural metalwork. These are simple or complex parametric objects whose definition requires the same care in defining their behavior as the base objects in a BIM design tool. Only a few new object classes have been defined for this class of building products (see Chapter 5, Section 5.4.2). Architects and fabricators sometimes build their own object classes for this use (see Figure 2–6 for an example) or rely on simpler nonparametric objects that users must continuously update and manage.

A functional difference in building modeling tools from that of other industries is the need to explicitly represent the space enclosed by building elements. Environmentally conditioned building space is a primary function of a building. The shape, volume, surfaces, environmental quality, lighting, and other properties of an interior space are critical aspects to be represented and assessed in a design.

Until recently architectural CAD systems were not able to represent building spaces explicitly; objects were approximated using a drafting system approach, as user-defined polygons with an associated space name. Credit is due to the General Services Administration (GSA) for demanding that BIM design applications be capable of automatically deriving and updating space volumes, beginning in 2007. Today, as shown in Table 2–1, most BIM design applications represent a building space as an automatically generated and

updated polygon defined by the wall intersections with a floor slab. The polygon is then extruded to the average ceiling height or possibly trimmed to a sloping ceiling surface. The older manual method has all the weaknesses of manual drafting: users must manage the consistency between wall boundaries and spaces, making updates both tedious and error-prone. The new definition is not perfect: it works for vertical walls and flat floors, but ignores vertical changes in wall surfaces, and often cannot reflect nonhorizontal ceilings.

Architects work initially with nominal building element shapes. But engineers and fabricators must deal with fabricated shapes and layouts that vary from nominal and must carry fabrication-level information. Also, shapes change due to pre-tensioning (camber and foreshortening), deflect due to gravity, and expand and contract with temperature. As building models become more widely used for direct fabrication, these aspects of parametric model shape generation and editing will require additional capabilities of BIM design applications.

Parametric modeling is a critical productivity capability, allowing low-level changes to update automatically. 3D modeling would not be productive in building design and production without the automatic update features made possible by parametric capabilities. However, there are hidden effects. Each BIM tool varies with regard to the level of implementation of parametric modeling, the parametric object families it provides, the rules embedded within it, and the resulting design behavior. Customizing the behaviors of the object classes provided involves a level of new expertise not widely available in current architecture, engineering, and fabrication offices.

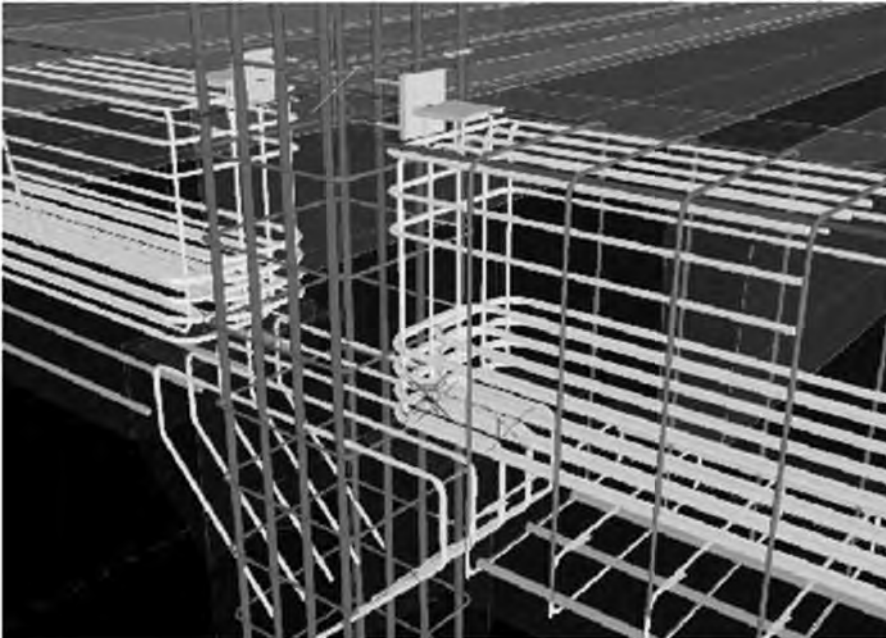
### **2.2.2 Parametric Modeling for Construction**

While BIM design intent applications allow users to assign layers to a wall section in terms of a 2D section, some architectural BIM design applications include parametric layout of nested assemblies of objects, such as stud framing, within a layer of a generic wall. This allows generation of the detailed framing and derivation of a cut lumber schedule, reducing waste and allowing for faster erection of wood or metal stud-framed structures. In large-scale structures, similar framing and structural layout options are necessary operations for fabrication. In these cases, objects are parts which are composed into a system—structural, electrical, piping, and the like—and the rules determine how the components are organized. Components often have features, such as connections, that are custom designed and fabricated. In the more complex cases, each of the system's parts are then internally composed of their constituent parts, such as steel reinforcing in concrete or complex framing of long-span steel structures.

A distinct set of BIM design applications have been developed for modeling at the more detailed fabrication levels. These tools provide different object

families for embedding different types of expertise (see Table 2–2). They are also related to different specific uses, such as materials tracking and ordering, plant management systems, and automated fabrication software. Early examples of such packages were developed for steel fabrication, such as Design Data’s SDS/2®, Tekla Structures®, and AceCad’s StruCad®. Initially, these were simple 3D layout systems with predefined parametric object families for connections, editing operations such as for copes that trim members for steel connections. These capabilities were enhanced to support automatic connection design based on loads and member sizing. With associated CNC cutting and drilling machines, these systems have become an integral part of automated steel fabrication. In a similar manner, systems have been developed for precast concrete, reinforced concrete, metal ductwork, piping, and other building systems.

Recent advances have been made in concrete engineering with cast-in-place and precast concrete. Figure 2–10 (see color insert) shows precast reinforcing embedded to meet structural requirements. The layout can be easily adjusted to the section size and to the layout of columns and beams. Parametric modeling operations can include shape subtraction and addition operations that create reveals, notches, bullnoses, and cutouts defined for connections to other parts. A precast fabrication-level architectural façade example is shown



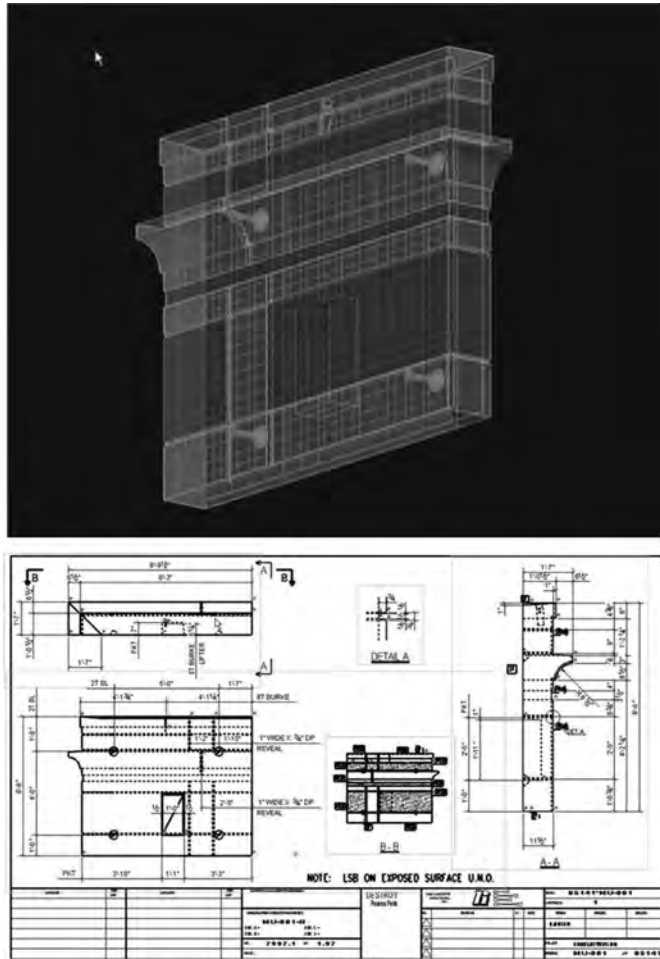
**FIGURE 2–10**

An automated reinforcing layout and connections for precast concrete in Tekla Structures.

**FIGURE 2-11**

A parametric model of an architectural precast panel and the piece mark drawing derived from it.

Image provided courtesy of High Concrete Structures.



in Figure 2-11, in terms of the 3D model of the piece and the piece mark (the drawing that describes one or more pieces of the same definition). Each building subsystem requires its own set of parametric object families and rules for managing the layout of the system. One set of rules defines the default behavior of each object within the system; another set defines how sections are cut and the layout format for drawing it.

Efforts are now underway within several construction material associations, such as the *American Institute of Steel Construction's Steel Design Guide* (AISC 2007), which currently encompasses 21 volumes, and the *Precast/Prestressed Concrete Institute's PCI Design Handbook* (PCI 2004). Members within these organizations have worked together to draft specifications for defining the layout and behaviors of objects in precast and steel design. Use of

these tools by fabricators is discussed in more detail in Chapter 7. It should be noted that despite the fact that fabricators have had a direct hand in defining these base object families and default behaviors, they often need to be further customized so that detailing embedded in the software reflects a company's specific engineering practices.

Two steel fabrication applications and three mechanical/electrical system BIM layout systems are summarized in Table 2–2. They show the relative coverage and embedded knowledge of these building system applications.

In fabrication modeling, detailers refine their parametric objects for well-understood reasons: to minimize labor, to achieve a particular visual appearance, to reduce the mixing of different types of work crews, or to minimize the types or sizes of materials. Standard design-guide implementations typically address one of multiple acceptable approaches for detailing. In some cases, various objectives can be realized using standard detailing practices. In other circumstances, these detailing practices need to be overridden. A company's best practices or standard interfacing for a particular piece of fabrication equipment may require further customization. In future decades, design handbooks will be supplemented in this way, as a set of parametric models and rules.

Several fabrication-level CAD systems in widespread use today are *not* general-purpose parametric object modeling BIM design applications. Rather, they are traditional B-rep modelers, possibly with a CSG-based construction tree and a given library of object classes. For many purposes, these are fine products. AutoCAD Architecture is a common platform for construction-level modeling tools such as CADPipe and CADDUCT, which are examples of such tools. We review AutoCAD MEP in Table 2–2 as one example. Some Bentley and Vectorworks products are also of this type, with fixed vocabularies of object classes. Within these more traditional CAD system platforms, users can select, parametrically size, and lay out 3D objects with associated attributes. These object instances and attributes can be exported and used in other applications, such as for bills of material, work orders, and fabrication. These systems work well when there is a fixed set of object classes to be composed using fixed rules. Appropriate applications include: piping, ductwork, and cable tray systems. Architectural Desktop was being developed in this way by Autodesk, incrementally extending the object classes it could model to cover those most commonly encountered in building, before it acquired Revit. New object classes can be added to these systems through the ARX or MDL programming language interfaces.

A critical difference between these earlier systems and BIM is that users can define much more complex structures of object families and relations among them than is possible with 3D CAD, without undertaking programming-level

software development. With BIM, a curtain wall system attached to columns and floor slabs can be defined from scratch by a knowledgeable nonprogrammer. Such an endeavor would require the development of a major application extension in 3D CAD. See for example the custom objects in Figure 2–6.

### 2.2.3 User-Defined Parametric Objects

Each BIM design application has an expanding set of predefined parametric object classes (see Tables 2–1 and 2–2), reflecting its target functionality. The architectural BIM applications' predefined objects generally capture conventions of design intent for architectural design. Currently, these also are frequently used to capture construction management (CM) information for construction coordination. However, the objects used in CM require additional information, dealing with tasks and schedules, material tracking, and other management links. Other applications have been developed, with different objects, for representing structural design and analysis information, and still others for representing information for different building subsystems, such as mechanical systems, plumbing, or electrical systems. Some applications focus on the design-intent level of detail and others at the fabrication level.

Each BIM application and the predefined objects that come with it are meant to capture the standard conventions in the area of building that the application targets. Most design and engineering domains have handbooks of standard practice. In architecture, this has for a long period been addressed by Ramsey and Sleeper's *Architectural Graphic Standards* (Ramsey and Sleeper 2000). In other areas, standard practice is captured by handbooks such as the AISC handbook *Detailing for Steel Construction* (AISC 2007), or the *PCI Design Handbook* (PCI 2004). *Standard practice* reflects industry conventions, how to design building parts and systems, based on current practices, often addressing safety, structural performance, material properties, and usage. Design behavior, on the other hand, has not been codified, resulting in different object behaviors in each of the BIM design tools. The base objects in each different BIM design tool is a repackaging of standard practice, as interpreted by the software company's software developers, often with input from industry groups and experts.

In the real world, however, these predefined objects and their built-in behaviors will be limiting at the design and fabrication stages, for a variety of reasons, some enumerated below:

- *A different configuration of parts* is desired for construction, analysis, or aesthetic reasons. A few examples are: a window with a Frank Lloyd Wright–inspired mitered glass corner; a custom window frame with

modeled thermal breaks; custom connections, such as for glass or plastics; development of a set of custom connections for steel, precast, or wood structures; connections for a space-frame.

- *The base parts do not address a specific design condition* encountered in a design or real-world context. Examples are a wall that sits on a stepped slab; a spiral ramp with varying slope; rooms with a domed ceiling.
- *A building system whose structure and behavior is not available by the software or building system vendors.* Examples are curtain wall and building skin systems; complex space types that embed expertise in their layout (for example, the building core example in Chapter 5) and also laboratories and medical spaces.
- *Some objects are not provided by the BIM design application.* Examples include: renewable energy objects, such as photovoltaic systems, and cisterns for thermal storage.
- *Improved objects incorporating company best practices.* These may involve detailing that requires extension to base objects, specific attributes, and associated detailing.

If a needed parametric object capability does not exist in the BIM tool, the design and engineering team has these options:

1. Creating an object in another system and importing it into your BIM tool as a reference object, without local editing capabilities
2. Laying out the object instance manually using solid modeling geometry, assigning attributes manually, and remembering to update the object details manually as needed
3. Defining a new parametric object family that incorporates the appropriate external parameters and design rules to support automatic updating behaviors, but the updates are not related to other object classes
4. Defining an extension to an existing parametric object family that has modified shape, behavior, and parameters; the resulting object(s) fully integrate with the existing base and extended objects
5. Defining a new object class that fully integrates and responds to its context.

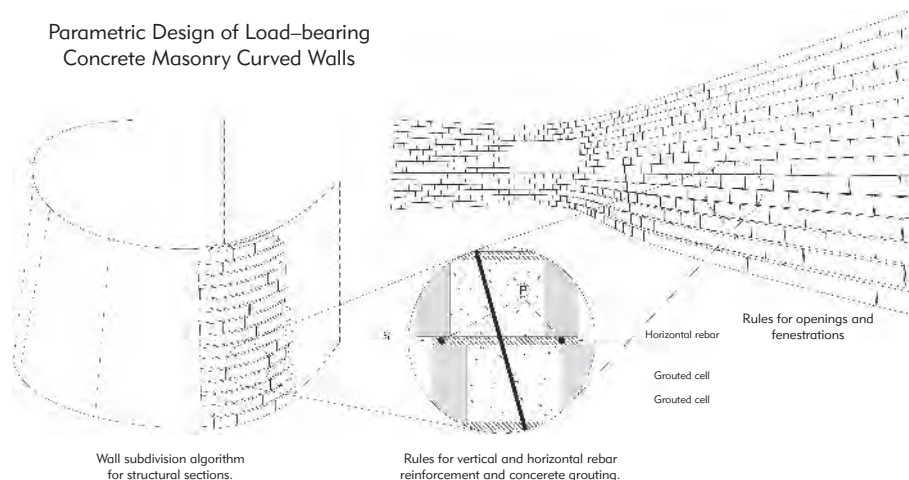
The first two methods listed above reduce the capabilities of piece editing to the CAD-level, without parametric representation. All BIM model generation tools support the definition of custom object families (points 3 and/or 4). These allow users to define new object classes that can update according to

the context defined within them. More challenging is the integration of new custom objects with existing predefined objects such as doors, walls, slabs, and roofs that are provided by the BIM tool. New objects need to fit into the BIM platform's already-defined updating structures; otherwise, the interfaces of these objects with others must be edited manually. These extended objects, for example, might include how to frame a particular style of stairway, keeping the code-related parameters for riser and tread. These objects and rules, once created, can be used in any project in which one wants to embed them. It is also important that the objects carry the attributes necessary for the various assessments that the object family's instances must support, such as cost estimation and structural or energy analyses. The updating structures in BIM applications are seldom documented by their developers, making this level of integration harder. Only some BIM design tools support this level of custom objects.

If a firm frequently works with some building type or system involving special object families, the added labor to define these parametrically is easily justified. They provide automatic application of company best practices in the various contexts found in different projects and can be applied firmwide. These may be at a high level for layouts or those needed for detailing and fabrication. Examples of such custom parametric objects are the custom masonry wall in Figure 2-12 (Cavieres et al. 2009) and the building core object, described in Chapter 5. The effect of these capabilities is to extend parametric modeling from a geometric design tool to a *knowledge embedding tool*. The implications of this capability in building design and construction are only beginning to be explored. Any firm that considers itself BIM-capable should have the ability

**FIGURE 2-12**

A custom parametric model for masonry (brick or block) freeform surface (curved in two directions). The object includes the management of trimming of pieces and the automatic assessment when reinforcing is required from Carieres (2009).





to define its own libraries of custom parametric object families to reflect the expertise and knowledge it has gained and can routinely apply.

The different types of BIM design tools are still in an evolutionary and maturing process. The largest effort has been directed toward addressing architectural design intent. The next level of effort has been to address some construction- and fabrication-level objects and behavior. BIM structural design tools are also available and are reviewed in Chapter 5. Other details are provided in Chapters 5, 6, and 7. As the range of renewable and sustainability procedures and control system issues grows, the need for BIM design tools for sustainability will also grow. The intellectual implications of defining object rules and behavior are not well explored.

---

## 2.3 BEYOND PARAMETRIC SHAPES

In this section, we go a bit deeper into the features of parametric modeling-based BIM systems, focusing on issues that extend beyond pure parametric geometric modeling.

### 2.3.1 Relational Structures

When we place a wall in a parametric model of a building, we can associate the wall to its bounding surfaces, its base floor planes, the walls its ends abut, any walls butting it, and the ceiling surfaces trimming its height. It also bounds the spaces on its two sides. These are all relations in the parametric structure that are then used to manage updates. When we put a window or door in the wall, we are defining another type of relation between the window and the wall (and also the spaces on both sides). Similarly, in pipe runs, it is important to define whether connections are threaded, butt-welded, or have flanges and bolts. Connections in mathematics are called *topology* and—distinct from geometry—are critical to the representation of a building model and are one of the fundamental definitions embedded in parametric modeling.

Other kinds of relations are also fundamental to parametric layouts. Reinforcing is contained in the concrete in which it is a part. Framing is part of a wall. Furniture is contained in a space object. *Aggregation* is the general term for “part of” relationships. It is a generalized relation that is used for accessing objects and is managed either automatically or manually in all BIM design systems. Aggregation is used for grouping spaces into departments, parts into assemblies, pieces into part orders, and pieces into erection sequences, for example. Rules can be associated with aggregations; how the assembly properties are derived from the part properties, for example.

Relations carry three important kinds of information: what can be connected or the parts of an aggregation; some relations have one or more features, such as how a connection modifies the parts to which it is connected; and last, the properties of the relation.

Relations are critical aspects of a BIM model specification that determines what kinds of rules can be defined between parts. They are also important as design objects and often require specification or detailing. In none of the BIM design tools is an explicit definition of the relations allowed and not allowed. They may be identified in an ad hoc manner embedded in documentation. Thus users will have to sort these out themselves. In architectural BIM design applications, connections are seldom defined as explicit elements. In fabrication-level BIM design applications, they are almost always explicit elements. To our knowledge, there has not been a careful study of the topological relations that should be supported in BIM applications.

### **2.3.2 Property and Attribute Handling**

Object-based parametric modeling addresses geometry and topology, but objects also need to carry a variety of properties if they are to be interpreted, analyzed, priced, and procured by other applications.

Properties come into play at different stages in the building lifecycle. For example, design properties address space and area names, properties for spaces such as occupancy, activities, and equipment performance needed for energy analysis. Zones (an aggregation of spaces) are defined with properties dealing with thermal controls and loads. Different system elements have their own properties, for structural, thermal, mechanical, electrical, and plumbing behaviors. Later, properties also address materials and quality specifications for purchasing. At the fabrication stage, material specifications may be refined to include bolt and weld and other connection specifications. At the end of construction, properties provide information and links to pass operating and maintenance data onto operations and maintenance.

BIM provides the environment to manage and integrate these properties over the project lifecycle. However, the tools to create and manage them are only starting to be developed and integrated into BIM environments.

Properties are seldom used singularly. A lighting application requires material color, a reflection coefficient, a specular reflection exponent, and possibly a texture and bump map. For accurate energy analysis, a wall requires a different set. Thus, properties are appropriately organized into sets and associated with a certain function. Libraries of property sets for different objects and materials are an integral part of a well-developed BIM environment. The property sets are not always available from the product vendor and often have

to be approximated by a user, the user's firm, or from the American Society of Testing and Materials data (ASTM). Although organizations such as the Construction Specifications Institute are addressing these issues (see Section 3.4.1 and 3.4.2), the development of property sets for supporting a wide range of simulation and analysis tools have not yet been adequately organized in a standard way for use; currently, they are left to users to set up.

Even seemingly simple properties can be complex. Take space names; they are used in spatial program assessment, functional analysis, and sometimes for early cost estimation and assigning energy loads and their schedules of use. Space names are building type-specific. Some organizations have tried to develop space name standards to facilitate automation. GSA has three different space name classifications for court houses: for building type spatial validation, another for lease calculations, and yet another set used in the U.S. Courts Design Guide. At both the department and individual space levels, Georgia Tech estimated there are about 445 different valid space names (Lee et al. 2010).

Current BIM platforms default to a minimal set of properties for most objects and provide the capability of extending the set. Users or an application must add properties to each relevant object to produce a certain type of simulation, cost estimate, or analysis and also must manage their appropriateness for various tasks. The management of property sets becomes problematic because different applications for the same function may require somewhat different properties and units, such as for energy and lighting.

At least three different ways exist that properties may be managed for a set of applications:

- By predefining them in the object libraries so they are added to the design model when an object instance is created
- By the user adding them as-needed for an application from a stored library of property sets
- By the properties being assigned automatically from a database as they are exported to an analysis or simulation application, based on an index or key

The first alternative is good for production work involving a standard set of construction types but requires careful user definition for custom objects. Each object carries extensive property data for all relevant applications, only some of which may actually be used in a given project. Extra definitions may slow down an application's performance and enlarge a project model's size. The second alternative allows users to select a set of similar objects or property

sets to export to an application. This results in a time-consuming export process. Iterated use of simulation tools may require the addition of properties each time the application is run. This would be required, for example, to examine alternative window and wall systems for energy efficiency. The third approach keeps the design application light but requires the development of a comprehensive material tagging system that can be used by all exporting translators to associate a property set for each object. The authors believe that this third approach is the desired long-term “solution” for property handling. The necessary global object classifications and name tagging required of this approach must still be developed. Currently, multiple object tags must be developed, one for each application.

The development of object property sets and appropriate object classification libraries to support different types of applications is a broad issue under consideration by the Construction Specification Institute of North America and by other national specification organizations. It is reviewed in more detail in Section 3.4.1 and 3.4.2.

Building Object Model (BOM) libraries, representing both objects and properties of specific commercial building products, are a potentially important part of a BIM environment for managing object properties. This type of facility is reviewed in Chapter 5, Section 5.4.

### **2.3.3 Drawing Generation**

Even though a building model has the full geometric layout of a building and its systems—and the objects have properties and, potentially, specifications and can carry much more information than drawings—drawings will continue to be required as reports extracted from or as specialized views of the model, for some time into the future. Existing contractual processes and work culture, while changing, are still centered on drawings, whether paper or electronic. If a BIM tool does not support effective drawing extraction and a user has to do significant manual editing to generate each set of drawings from cut sections, the benefits of BIM are significantly reduced.

With building information modeling, each building object instance—its shape, properties, and placement in the model—is represented only once. Based on an arrangement of building object instances, all drawings, reports, and datasets can be extracted. Because of this nonredundant building representation, all drawings, reports, and analysis datasets are consistent if taken from the same version of the building model. This capability alone resolves a significant source of errors. With normal 2D architectural drawings, any change or edit must be manually transferred to multiple drawing views by the designer, resulting in potential human errors from not updating all drawings correctly. In

precast concrete construction, this 2D practice has been shown to cause errors costing approximately 1 percent of construction cost (Sacks et al. 2003).

Architectural drawings do not rely on orthographic projections, as learned in high school drafting classes. Rather, building plans, sections, and elevations incorporate complex sets of conventions for recording design information graphically on sheets of paper that vary for different systems. This includes symbolic depiction of some physical objects, dotted representation of geometry behind the section plane in floor plans, and very selective dotted-line representation of hidden objects in front of the section plane, in addition to line-weights and annotations. Mechanical, electrical, and plumbing systems (MEP) are often laid out in different ways in different stages of design. These different conventions require BIM design applications to embed a strong set of formatting rules in their drawing extraction capabilities. In addition, individual firms often have their own drawing conventions that must be added to the built-in tool conventions. These issues affect both how the model is defined within the tool and how the tool is set up for drawing extraction.

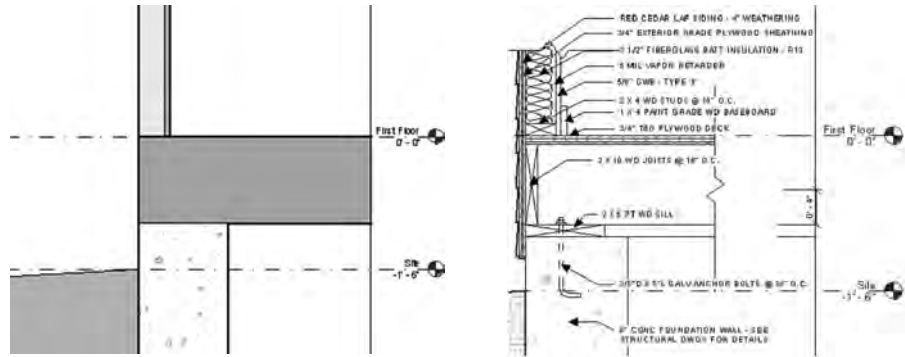
Part of a given drawing definition is derived from the object definition. The object has an associated name, annotation, and in some cases view properties with line weights and formats for presentation that are carried in the object library. The placement of the object also has implications. If the object is placed relative to a grid intersection or wall end, that is how its placement will be dimensioned in the drawing. If the object is parametrically defined relative to other objects, such as the length of a beam placed to span between variably placed supports, then the drawing generator will not automatically dimension the length unless the system is told to derive the beam length at drawing generation time. Some systems store and place associated annotations with object sections, though these annotations often need shifting to achieve a well-composed layout. Other annotations refer to details as a whole, such as name, scale, and other general notes and these must be associated with the overall detail. Drawing sheets also include a site plan, which shows the building's placement on the ground plot relative to recorded geospatial datum. Some BIM design applications have well-developed site-planning capabilities, others do not. Table 2-1 shows which BIM design applications include site objects. Current BIM design tool capabilities come close to automated drawing extraction, but it is unlikely that automation ever will be 100 percent complete.

Most buildings involve thousands of objects, from girders and foundation pads to baseboards and nails. It is usually thought that some types of objects are not worth modeling. They must still be depicted in the drawings for correct construction, however. BIM design tools provide the means for extracting a drawn section at the level of detail to which they are defined in the 3D model

**FIGURE 2-13**

Sketch showing the initial section extracted from the building model (left) and the manually detailed drawing elaborated from the section (right).

Image provided courtesy of Autodesk.



(with certain objects selectively turned off). The location of the drawn section is automatically recorded with a section-cut symbol on a plan or elevation as a cross-reference and the location can be moved if needed. The section is then detailed manually with the needed wood-blocks, extrusions, silicon beading, and weather stripping; and associated annotations provided in the fully detailed drawn section. An example is shown in Figure 2-13, with the figure on the left showing the extracted section and the one on the right showing the detailed section with drafted annotation. In most systems, this detail is associated with the section cut it was based on. When 3D elements in the section change, they update automatically in the section but the hand-drawn details must be manually updated.

To produce drawings, each plan, section, and elevation is separately composed based on the above rules from a combination of cut 3D sections and aligned 2D drawn sections. They are then grouped into sheets with normal borders and title sheets. The sheet layouts are maintained across sessions and are part of the overall project data.

Drawing generation from a detailed 3D model has gone through a series of refinements to make it efficient and easy. Below is an ordered list of the levels of quality that can now be supported technically, though most systems have not realized the top level of capability for drawing generation. We start from the weakest level.

1. A weak level of drawing production provides for the generation of orthographic sections cut from a 3D model, and the user manually edits the line formats and adds dimensions, details, and annotations. These details are associative. That is, as long as the section exists in the model, the annotation setup is maintained across drawing versions. Such association capabilities are essential for effective regeneration of drawings for

multiple versions of the design. In this case, the drawing is an elaborated report generated from the model. The drawing generation may be done either in an external drafting system or within the BIM tool.

2. An improvement upon this level is the definition and use of drawing templates associated with elements for a type of projection (plan, section, elevation) that automatically generates dimensioning of the element, assigns line weights, and generates annotations from defined attributes. This greatly speeds up the initial drawing setup and improves productivity, though the initial setup of each object family is tedious. Template layout defaults can be overwritten and custom annotations added. Edits cannot be made to the model projections; these have to be made in the model view. In these first two cases, report management should be provided to inform the user that model changes have been made, but the drawings cannot automatically update to reflect these changes until they are regenerated.
3. Current top-level drawing functionality supports bidirectional editing between models and drawings. Changes to model annotations are the same as described above. However, model edits are supported in the drawing view and are propagated to the model. If displayed in windows alongside views of the 3D model, updates in any view can be referenced immediately in the other views. Bidirectional views and strong template generation capabilities further reduce the time and effort needed for drawing generation.

Door, window, and hardware schedules are defined in a similar way to the three alternatives described above. That is, they may be generated as reports and only locally edited. Schedules can also be treated as model views and in some systems can be updated directly, modifying the building model. A static report generator method is weakest, and a strong bi-directional approach is strongest. Such bi-directionality offers useful benefits, including the ability to trade hardware used on a set of doors with hardware recommended on the schedule, rather than from the model. Edits made to a model from a schedule require care, however, and model corruption is often encountered as a result of this type of editing.

In fabrication-level BIM modeling systems, this mixed system of schematic 3D sectional layout and 2D detailing is greatly reduced, and the design is assumed to be generated primarily from the 3D object model. In these cases, joists, studs, plates, plywood sills, and other pieces, shown in Figure 2-13, would be laid out in 3D.

An obvious current goal is to automate the drawing production process as much as possible, since most initial design productivity benefits (and costs)

will depend on the extent of automatic generation. At some future point in time, most parties involved in the building delivery process will adapt their practices to BIM technology and not require drawings and work directly from building models; we are slowly moving to a paperless world (see Chapter 8 for a discussion). Drawings will continue to be used, but as throw-away mark-up sheets by construction crews and other users. As these changes take place, the conventions regarding architectural drawings are likely to evolve, allowing them to be customized for the specific task in which they are used. Some examples are presented in Chapter 5.

BIM technology generally allows designers to choose the level of 3D modeling to use, with 2D drawing sections filling in the missing details. The BIM benefits of data exchange, bills of material, detailed cost estimation, and other actions are lost on those elements defined only in 2D section drawings. While it can be argued that complete 3D object modeling is not warranted, the advanced users of BIM are moving toward 100 percent modeling (see, for example, the Sutter Medical Center case study in Chapter 9). The mixed technology is good for firms at all levels of BIM utilization; beginners can use drawn sections to incrementally adopt BIM on projects, while advanced users can develop new uses in a step-by-step manner, adding the level of detail to modeling that the benefits require.

#### 2.3.4 Scalability

A problem that many users encounter is scalability. Problems in scaling are encountered when a project model gets too large for practical use. Operations become sluggish, so that even simple operations are laborious. Building models take a lot of computer memory space. Large buildings can contain millions of objects, each with a different shape. Scalability is affected by both the size of the building, say in floor area, and also by the level of detail in the model. Even a simple building can encounter scalability problems if every nail and screw is modeled.

Parametric modeling incorporates design rules that relate geometry or other parameters of one object with those of other objects. These come in a hierarchy of relations: *within object* parametric relations, *peer object* relations, adjusting one object's shape in response to the change of another object, and *hierarchical relations* between control grids and surfaces that determine the parameters of shape and placement of a set of associated objects. While within object and peer object relations update locally, hierarchical rule propagation may generate updates to the whole building. Local parametric rule propagation makes only reasonable demands on models, while some system architectures limit the ability to manage propagation of large sets of hierarchical rules.



Also, it is hard to partition a project into parts for separate development and still manage a large set of hierarchical rules.

The issue is memory size; all operations on object shapes must take place in memory. The simple solution to manage parametric updates is to carry the project in memory. This challenges scalability and places practical limits on the size of a project module that can be effectively edited. However, if rules can be propagated across files, where updating an object in one file can lead to automatic updates propagated to other files, the size limitation of a project disappears. Only a few BIM design applications developed especially for architecture have the means for managing parametric change propagation across multiple files. We call systems that must carry all updated objects in memory simultaneously *memory-based*. When the model gets too large to be held in memory, virtual memory-swapping occurs, which can result in significant waiting time. Other systems have methods of propagating relations and updates across files and can open, update, and then close multiple files during an edit operation. These are called *file-based* systems. File-based systems are generally a bit slower for small projects but their speed decreases very slowly as project size grows.

User segmentation of projects into modules has been a time-tested way of sharing work and limiting the scale of automatic updates. Reference files are often used to also limit what can be edited. These work well if hierarchical relations in a project don't lead to global project changes. Some BIM tools impose these limitations.

Memory and processing issues will naturally decrease as computers get faster. Sixty-four-bit processors and operating systems also provide significant help. There will be the parallel desire, however, for more detailed building models and larger sets of parametric rules. Issues of scalability will be with us for some time.

### 2.3.5 Object Management and Links

#### **Object Management**

BIM models become quite large and complex. Multigigabyte models are becoming common. In such cases data coordination and management (what is called “synchronization” in Chapter 3) becomes a large data management task and concern. The traditional approaches to updating versions of a project using files leads to two kinds of problems:

1. Files become huge and the project must be partitioned in some way to allow design to continue; the files are large, slow, and cumbersome.
2. Determining the changes within a file is still a manual management effort, replacing a red marker on drawings in drafting with notes in a

3D PDF or similar reviewing file. Traditionally, major changes at the construction document stage were not allowed because of their prohibitive cost. BIM and model management is supposed to eliminate or greatly reduce this problem. While parametric updates resolve issues of local changes, the coordination of different models and their derived data for schedules, analyses, and reports is still an important and growing issue.

The long-mentioned but only recently realized capability of only exchanging the new, modified or deleted object instances in a file, eliminating the “chaff” of the nonmodified objects has now been brought out in a production environment, notably ArchiCAD’s Delta BIM server (more fully reviewed in Chapter 3, Section 3.5.3). Transferring only the changed objects and importing them, called an *incremental update*, greatly reduces the size of the exchange files, and allows for immediate identification and targeting of the change issues. This capability requires object identification and version control at the object level, usually provided by a timestamp. This capability will become increasingly important as BIM models grow. It will become a “must” feature on future releases of all systems, for coordination across multiple BIM applications.

### ***External Parameter Management***

A capability explored in a number of innovative projects has been to control the geometric layout of a design based on control parameters (often a 3D grid) generated and defined in a spreadsheet. An example application of using a spreadsheet to control and coordinate geometry is presented in both the building core model in Chapter 5 and the Aviva Stadium case study project reviewed in Chapter 9, Section 9.1.

For certain types of projects, the ability to read from and write to spreadsheets provides a level of interoperability among different design tools. Suppose the equivalent parametric models can be built in two different modeling environments, say Rhino and Bentley, with the same parameters controlling the geometry. Design explorations can be made in Rhino, generally a friendly but information-limited design tool, then the parameters updated in Bentley Architecture, allowing the changes to be integrated in a BIM tool that might have cost or energy analysis capabilities. The spreadsheet provides an important level of geometric interoperability.

Another use of external spreadsheets of parameter lists is to exchange parametric objects by reference, rather than explicitly. The best-known example is steel structures. Steel handbooks, now in digital forms, carry the different standard profiles for structural steel, such as W18X35 or L4X4. These profile names can be used to retrieve profile, weight, and mass properties from

the steel handbooks. Similar profiles are available for precast concrete products, reinforcing bars, and some window manufacturer catalogs. If the sender and the receiver each have access to the same catalog, then they may send and retrieve the relevant information by reference (name) and the exchange is made by retrieving the appropriate catalog information and loading it into the appropriate parametric model for the part. This is a significant capability in many production areas.

### ***Links to External Catalog Files***

Another important capability is to provide links to external files. The primary use of this capability today is to link products with their associated manuals for maintenance and operation, for later association with facilities operation and maintenance (O&M). Some BIM tools offer this capability and enhance their value as being a tool that can provide support during the O&M stage.

The functional capabilities outlined in this section are all important in assessing and selecting a BIM platform. They will be used later in this chapter when we assess the major BIM design tools.

## **2.3.6 Some Commonly Asked Questions**

There are many questions associated with BIM and the computer-aided design systems that are considered BIM design applications. This section attempts to answer the most common ones.

### ***Strengths and Limitations of Object-Based Parametric Modeling***

One major benefit of parametric modeling is the intelligent design behavior of objects. Automatic low-level editing is built in, almost like one's own design assistant. This intelligence, however, comes at a cost. Each type of system object has its own behavior and associations. As a result, BIM design applications are inherently complex. Each type of building system is composed of objects that are created and edited differently, though with a similar user interface style. Effective use of a BIM design application usually requires months to gain proficiency.

Modeling software that some users prefer, especially for early concept design, such as SketchUp, Rhino, and FormZ's Bonzai, are not parametric modeling-based tools. Rather, they have a fixed way of geometrically editing objects, which varies only according to the surface types used. This functionality is applied to all object types, making them much simpler to use. Thus, an editing operation applied to walls will have the same behavior when it is applied to slabs. In these systems, attributes defining the object type and its functional

intention, if applied at all, can be added when the user chooses, not when it is created. All of these systems allow the grouping of surfaces, giving the group a name and maybe assigning attributes. Done carefully and with a matching interface, the object can be exported and used in other areas, say solar gain studies. This is similar to the kinds of tricks people used to do with 3D AutoCAD. But one is not going to take this kind of modeling into design development because one object is not linked to other objects and must be spatially managed individually. An argument can be made that for preliminary design use, however, BIM technology with its object-specific behavior is not always warranted. This topic is explored further in Chapter 5.

### ***Why Can't Different Parametric Modelers Exchange Their Models?***

It is often asked why firms cannot directly exchange a model from Revit with Bentley Architecture, or exchange ArchiCAD with Digital Project. From the overview discussed previously, it should be apparent that the reason for this lack of interoperability is due to the fact that different BIM design applications rely on different definitions of their base objects and their behaviors. A Bentley wall behaves differently than a Vectorworks wall or a Tekla wall. These are the result of different capabilities involving rule types in the BIM tool and also the rules applied in the definition of specific object families. This problem applies only to parametric objects, not those with fixed geometry. If the shapes are accepted in their current form as fixed and their behavioral rules are dropped, an ArchiCAD object can be used in Digital Project; a Bentley object can be used in Revit. The issues of exchange are resolvable. The problem is exchanging object behavior (which is not often needed). Behavior also could be exchanged if and when organizations agree on a standard for common building object definitions that includes not only geometry but also behavior. Until then, exchanges for some objects will be limited or will fail completely. Improvements will come about incrementally, as the demand to resolve these issues makes implementation worthwhile, and the multiple issues are sorted out. The same issue exists in manufacturing and has not yet been resolved.

### ***Are There Inherent Differences in Construction, Fabrication, and Architectural BIM design applications?***

Could the same BIM platform support both design and fabrication detailing? Because the base technology for all of these systems has much in common, there is no technological reason why building design and fabrication BIM design applications cannot offer products in each other's area. This is happening to some degree with Revit Structures and Bentley Structures. They are developing some of the capabilities offered by fabrication-level BIM design applications.

On the other side, there are a few cases where Tekla has been used to design and build houses. Both sides address the engineering market and, to a lesser degree, the contractor market; but the expertise needed to support full production use in these information-rich areas will depend on major front-end embedding of requisite object behaviors, which are distinctly different for different building systems and their lifecycle needs. Expert knowledge of specific building system object behaviors is more readily embedded when it is codified, as it is, for example, in structural system design. The interfaces, reports, and other system issues may vary, but we are likely to see skirmishes in the middle-ground for a significant period of time, as each product attempts to broaden its market domains.

### ***Are There Significant Differences Between Manufacturing-Oriented Parametric Modeling Tools and BIM Design Applications?***

Could a parametric modeling system for mechanical design be adapted for BIM? Some differences in system architecture are noted in Sections 2.1.4 and 2.3.1. Mechanical parametric modeling tools have already been adapted for the AEC market. Digital Project, based on CATIA, is an obvious example. Also, Structureworks is a precast concrete detailing and fabrication product using Solidworks as a platform. These adaptations build in the objects and behavior needed for the target system domain. Building modelers are organized as top-down design systems, while manufacturing parametric tools were originally organized bottom-up. Because of manufacturing systems' structure, where different parts were originally different "projects," they have addressed the challenge of propagating changes across files, making them often more scalable. In other areas, such as plumbing, curtain wall fabrication, and ductwork design, we can expect to see both mechanical parametric modeling tools and architectural and fabrication-level BIM design applications vying for these markets. The range of functionality offered in each market is still being sorted out. The market is the battleground.

### **2.3.7 Summary**

In this section, we have tried to articulate several different issues:

- The differences between previous CAD systems and BIM design applications
- The similarities and differences between BIM design applications and more general object-based parametric modeling systems used by other industries
- The differences between BIM design applications used in architectural design and those used in fabrication

## 2.4 BIM ENVIRONMENTS, PLATFORMS, AND TOOLS

This chapter has, so far, provided an overview of the basic capabilities of BIM design applications resulting from their development as object-based parametric design tools. We now turn to reviewing the main BIM design applications and their functional differences. We have considered parametric modeling applications up to this point in a homogeneous manner, primarily as tools for generating design information, and possibly for structuring it and managing it. In considering their use in more detail, we note that most BIM design applications aspire to be more than a design tool. Most BIM design applications also have interfaces to other applications, for rendering, energy analysis, cost estimation, and so forth. Some also provide multiuser capabilities that allow multiple users to coordinate their work.

In planning and developing BIM within an organization, it is useful to think of it in system architecture terms. BIM, in most organizations, will involve multiple applications, for different uses. How are the different applications to be conceptualized and organized? Large firms will typically support and in some sense integrate 10 to 50 different applications for their employees' use.

We make explicit use of some terms that long have been used informally, to consider BIM applications in the following hierarchy:

- **BIM tool:** a task-specific application that produces a specific outcome; example tools are those for model generation, drawing production, specification writing, cost estimation, clash and error detection, energy analysis, rendering, scheduling, and visualization. Tool output is often standalone, as reports, drawings, and so forth. In some cases, however, tool output is exported to other tool applications, such as quantity takeoffs to cost estimation, and structural reactions fed to a connection-detailing application.
- **BIM platform:** an application, usually for design, that generates data for multiple uses. It provides a primary data model that hosts the information on the platform. Most BIM platforms also internally incorporate tool functionality such as drawing production and clash detection. They typically incorporate interfaces to multiple other tools with varied levels of integration. Some platforms share the user interface and style of interaction. Digital Project is structured in this way, with its Structure, Imagine and Shape, and System Routing tools organized within their system as Workbenches.
- **BIM environment:** the data management of one or more information pipelines that integrate the applications (tools and platforms) within an organization. It supports policies and practices of information within

the organization. Often the BIM environment is not conceptualized and grows in an ad hoc manner by the needs within the firm. Automatic generation and management of multiple BIM tool datasets is their obvious use. Also, when multiple platforms are used, and thus multiple data models, another level of data management and coordination is required. These address tracking and coordinating communication between people as well as multiple platforms. BIM environments provide the opportunity to carry much wider forms of information than model data alone, such as video, images, audio records, emails, and many other forms of information used in managing a project. BIM platforms are not set to manage such diverse information. BIM servers, reviewed in Chapter 3, Section 3.5, are the new products targeted to support BIM environments. In addition, the BIM environment includes object and assembly libraries for reuse, interfaces to the applications the organization supports, and links to corporate management and accounting systems.

BIM platforms have sufficient information to support design operations of object creation, editing, and modification. They carry parametric and other rules important for maintaining the correctness of a building model spatially. They may have multiple embedded tools for 3D modeling, quantity takeoff for rendering, and for drawing production. BIM tools, in contrast, lack the structure and rules for correctly updating the building design. They provide analyses, track and package data for costs or schedules, and generate specifications and possibly generate renderings or animations. Platforms are often also informally used as the BIM environment, relying on one platform to provide all the services within an organization and providing the integration environment for the organization. Platform vendors promote this, through their offering of the proverbial “complete solution.”

Up to this point, we have used the generic term *application* without distinguishing these three levels. In future chapters, we will use these concepts explicitly in the way they are defined here.

---

## 2.5 OVERVIEW OF THE MAJOR BIM DESIGN PLATFORMS

In this section, we summarize the major functional and performance capabilities that distinguish different BIM platforms, considered as having both tool and platform functionality, as presented in earlier sections of this chapter. We also consider them in relation to their supporting a BIM environment. The capabilities apply to both design-oriented systems as well as fabrication BIM design

tools. These distinguishing capabilities are proposed for those wishing to undertake a first-level review and assessment of alternative systems, so as to make a well-informed decision within the project, office, or enterprise. The choice affects production practices, interoperability, and to some degree, the functional capabilities of a design organization to do particular types of projects.

We organize the important features at three levels of applicability: as a tool, as a platform, and as an environment, as defined in Section 2.4. We emphasize that no one application will be ideal for all types of projects. Ideally, an organization would have several platforms that it supports and moves between for specific projects. Some uniquely support communication between different applications; others may support collaboration with a particular fabricator or consultant. Fabricators are less likely to need multiple platforms.

Adopting a BIM design application, as a tool and/or platform, is a significant undertaking. Adoption is also discussed in later chapters, especially regarding their intended use, for design and engineering in Chapter 5, for contractors and construction management in Chapter 6, and for fabricators in Chapter 7. They are also considered for their support of being managed within a BIM environment, as developed in Chapter 3. Decisions about applications involve understanding new technologies, the new organizational skills needed, and then learning and managing those skills. These challenges will recede over time, as the learning curve and practices surrounding BIM use become more ingrained in practice. Because the functionality of BIM design applications is changing quickly, it is important to look at reviews of the current versions in *AECBytes*, *Catalyst*, or other AEC CAD journals and collaboration sites such as LinkedIn.

Within the common framework of providing object-based parametric modeling, BIM design applications embody many different kinds of capabilities, some at the tool and some at the platform levels. We discriminate the issues associated with their use as a tool and as a platform, with comments about their support at the BIM system environment level.

### 2.5.1 As a BIM Design Tool

Below, we describe the discriminating design tool capabilities in rough-rank based on our sense of their level of importance. We take parametric model generation and editing as fundamental. We assume that model definition and drawing production are the current primary tool-level uses for building modeling systems. Model generation and editing is considered multifaceted, in terms of user interface, custom objects, and complex surface modeling.

**User Interface:** BIM design tools are quite complex and have much greater functionality than earlier CAD tools. Some BIM design tools have a relatively



intuitive and easy-to-learn user interface, with a modular structure to their functionality, while others place more emphasis on functionality that is not always well-integrated into the overall system. Criteria to be considered here include: consistency of menus across the system's functionalities following standard conventions; menu-hiding that eliminates irrelevant actions not meaningful to the current context of activities; modular organization of different kinds of functionality and online help providing real-time prompts and command-line explanation of operations and inputs. While user interface issues may seem minor, a poor user interface results in longer learning times, more errors, and often not taking full advantage of the functionality built into the application. User interface issues across a set of integrated tools are also important at the platform level; we review those issues in the next section.

**Drawing Generation:** How easy is it to generate drawings and drawing sets and to maintain them through multiple updates and releases? Assessment should include quick visualization of the effects of model changes on drawings, strong associations so that model changes propagate directly to drawings and vice versa, and effective template generation that allows drawing types to carry out as much automatic formatting as possible. A more thorough review of functionality is provided in Section 2.3.3.

**Ease of Developing Custom Parametric Objects:** This is a complex capability which can be defined at three different levels:

- (1) Existence and ease-of-use of a sketching tool for defining parametric objects; determining the extent of the system's constraint or rule set (a general constraint rule set should include distance, angle including orthogonally, abutting faces and line tangency rules, "if-then" conditions and general algebraic functions)
- (2) ability to interface a new custom parametric object into an existing parametric class or family, so that an existing object class's behavior and classification can be applied to the new custom object
- (3) ability to support global parametric object control, using 3D grids or other control parameters that can be used to manage object placement, sizing, and surface properties, as required for the design. These issues are explained further in Section 2.2.1.

**Complex Curved Surface Modeling:** Support for creating and editing complex surface models based on quadrics, splines, and nonuniform B-splines is important for those firms that currently do this type of work or planning to in the future. These geometric modeling capabilities in a BIM tool are foundational; they cannot be added on later.

**Other Tool-Level Capabilities:** Support for tool capabilities beyond the basics include clash detection, quantity takeoffs, issue tracking, and incorporation of product and construction specifications. These are appropriate for different uses and workflows and are considered in more detail in Chapters 5, 6, and 7. We also consider the support provided by a large user community on the Web.

### 2.5.2 As a BIM Platform

Below we describe the major discriminating capabilities of an application meant to serve as a design platform. The basic functionality of BIM design applications was initiated as a tool and began serving the idea of a platform as the uses of building model information were recognized. The requirements of a BIM platform have grown in importance as the potential uses of building information have increased. Most BIM platforms operate on the Microsoft Windows platform with a wide range of interfacing tools; a few support the Apple Macintosh, where the range of applications to interface with is fewer. We enumerate them in rough-rank order, based on our sense of their level of importance.

**Scalability:** This is the ability to handle combinations of a large project scale and modeling at a high level of detail. This involves the ability of the system to remain responsive regardless of the number of 3D parametric objects in the project. This capability can be important at the tool level, but the scope of a tool at any one time is usually limited. The scalability of a design becomes critical when hierarchical parameters are used to manage large sections of façade or the whole building envelope. A fundamental issue is the degree that the system is disk-based, in terms of data management, rather than memory-based. Disk-based systems are slower for small projects because of disk read/write speeds, but their delay time grows slowly as the project size grows. Memory-based systems are usually quicker under light loads, but performance drops quickly once memory space is exhausted. Scalability is partially limited by the operating system; Windows XP, 32-bit version, without special settings, only supports up to 2 gigabytes of working memory for a single process. Sixty-four-bit architectures for Windows and Snow Leopard eliminate the memory use restriction and are becoming inexpensive and common. Graphic card performance also is important for some systems. This topic is discussed in more detail in Section 2.3.4.

**Tool Interfaces:** As a platform, a BIM application needs to be able to present a large range of information, as geometry, properties, and as relations between them, to other applications. Typical uses include structural,

energy, lighting, costs, and other analyses during design; clash detection and issues tracking for design coordination; purchasing and materials tracking; and task and equipment scheduling for construction. Tool interfaces of importance depend on the intended use of the BIM platform, defined by particular patterns of workflow. We assess their appropriateness in the tools and workflows in the chapters that address their use in different contexts—Chapters 5, 6, and 7.

**Libraries of BIM Elements:** Each BIM platform has various libraries of predefined objects that can be imported for use. These can be helpful by eliminating the need to define them yourself. In general, the more predefined objects, the more helpful. There is a further level of discrimination regarding how good the objects are for different uses. Currently, there is little effort to standardize the structure of object information beyond geometry. Here we are referring to specifications for selection, specifications for use in analyses, service manuals, material properties for use in rendering, and other similar uses. Only the smartBIM Library, reviewed in Chapter 5, has begun to address these issues, to our knowledge. In considering different platforms, the availability of predefined building objects facilitates work on that platform.

**Platform User Interface Consistency:** Platform interfaces have different criteria according to two different scenarios of use. In one case, the tools are operated by specialists in different departments in a large firm, or by consultants. In this case, each tool has its own logic and is addressed in the tool-level criteria. In the other scenario, the tools are shared and used by multiple platform users. In this case, the consistency across tools is very important, for ease of learning and use. It is a challenge because of the wide range of functionality to be supported.

**Extensibility:** Extensibility capabilities are assessed based on whether a BIM platform provides scripting support—an *interactive language* that adds functionality or automates low-level tasks, similar to AutoLISP® in AutoCAD—an Excel format bidirectional interface, and a broad and well-documented application programming interface (API). Scripting languages and Excel interfaces are generally for end users, while an API is intended for software developers. These capabilities are needed depending on the extent to which a firm expects to customize capabilities, such as custom parametric objects, specialized functions, or interfaces to other applications.

**Interoperability:** Model data is generated, in part, to share with other applications for early project feasibility studies, for collaboration with engineers and other consultants and later for construction. Collaboration is

supported by the degree that the BIM platform provides interfaces with other specific products and, more generally, its import and export support of open data exchange standards. Both these types of interfaces are reviewed in detail in Chapter 3. The open exchange standards are getting more elaborate, starting to support workflow-level exchanges. This requires export and import translations to be varied. An easily customizable import and export facility is highly beneficial. Both tool interfaces and the more general aspects of interoperability are considered here.

**Multiuser Environment:** Some systems support collaboration among a design team. They allow multiple users to create and edit parts of the same project directly from a single project file and manage user access to these various information parts. This can work in a disk-based platform. It makes less sense in a memory-based BIM platform, where the multiple users are competing for the same address space and hardware resources.

**Effective Support for Managing Properties:** Properties are an integral part of the data needed for most BIM support tools. Property sets need to be easily set up and associated with the object instances they describe. Tools for this capability vary a lot on different platforms.

### 2.5.3 As a BIM Environment

At the beginning of the BIM age, it was thought that a single application could serve the needs at all three levels: as a tool, as a platform, and as an environment. That idealism has slowly waned, as the scale of a BIM project and the systems to support it have become understood. An important capability needed to globally support advanced BIM projects is to support work in a multiplatform and multipresentation environment. A BIM environment needs the ability to generate and store object instances for different tools and platforms and to manage that data effectively, including change management at the object level. This issue is addressed more centrally in Chapter 3, Section 3.5. This can be handled by a change flag or a timestamp that gets updated whenever an object is modified. The goal is to exchange and manage objects and sets of objects rather than files.

Below we offer an overview of the current capabilities of the major building model generation platforms. Some reviewed support only architectural design functions, others only various types of fabrication-level building systems, and others both. Each assessment is for the version of the software system noted; later versions may have better or worse capabilities. We review them according to the criteria developed above.

---

## 2.6 BIM PLATFORMS

BIM platforms may be used in diverse ways in building construction: by the architect for design modeling and drawing production, by an engineer for structural or energy data management, by a contractor for developing a construction coordination model, for fabrication detailing or for facility management, for example; they include varying types of tool functionality. Some are marketed to multiple types of user. The different marketing strategies lead to packages with different collections of functionality. In this review, we do not address these different uses but consider the major BIM platforms generically, from the perspective of its primary product, with references to other products running on the same platform. Their uses and limitations will be considered more explicitly in the chapters associated with the different types of BIM users. We consider each platform from the three levels outlined in Section 2.3: as a tool, as a platform, and as an environment.

As is broadly understood, the acquisition of a software package is very different from most other purchases we make. Whereas the purchase of a car is based on a very specific product and set of features, a software package involves both its current capabilities and the development path of enhancements that are released regularly, at least annually. A purchaser is buying into both the current product and its future evolutions, as projected by the company. One is also purchasing a support system that at least one person in a firm will be dealing with. The support system is an augmentation of the user-provided documentation and online support built into the BIM tool. Apart from the vendor's support network, a software system owner is also part of a broader user community. Most provide blog communication for peer-to-peer help and open portals for the exchange of object families. These may be free or available at a small cost. These also should be considered in the acquisition of a BIM platform.

### 2.6.1 Revit

We consider the Revit platform from the perspective of Revit Architecture. Revit is the best-known and current market leader for BIM in architectural design. It was introduced by Autodesk in 2002 after Autodesk acquired the Revit program from a startup company. Revit is a completely separate platform from AutoCAD, with a different code base and file structure. The version reviewed here is 2011. Revit is a family of integrated products that currently includes Revit Architecture, Revit Structure, and Revit MEP. It runs on Windows OS and on Macs, using the Windows BootCamp® plug-in. It runs on both 32- and 64-bit processors and versions of the OS.

*As a tool:* Revit provides an easy-to-use interface, with drag-over hints for each operation and smart cursor. Its menus are well organized according to workflow and its operator menus gray-out nonavailable actions within the current system context. Its drawing generation support is very good; its drawing production is strongly associative, so that drawing releases are easily managed. It offers bidirectional editing from drawings to and from the model, and also bidirectional editing from schedules for doors, door hardware, and the like. Revit supports the development of new custom parametric objects and customization of predefined objects. Its rule set for defining objects has improved with each release and includes trigonometric functions. It can constrain distances and angles and the number objects in an array. It also supports hierarchical relations of parameters. Thus, an object can be defined by using a group of sub-objects with parametric relations. It is more difficult to set up global parameters that can constrain assemblies of objects' layout and sizes. The release of the current API provides good support for external application development.

Revit has a very large set of product libraries, particularly its own Autodesk SEEK library for specification and design objects. It carries information for about 850 different companies, and about 13,750 different product lines (including over 750 light fixtures). The products are defined in a mixture of file types: RVA, DWG, DWF, DGN, GSM, SKP, IES, and TXT. They are accessible from Masterformat, Unifomat, and Omniclass Table 23 (Products) formats. There are about a half-dozen other sites with BIM products, where Revit objects dominate.

*As a platform:* Revit, as the BIM market leader, has the largest set of associated applications. Some are direct links through Revit's Open API and others are through IFC or other exchange formats. These are denoted (Dir) and (IFC), respectively. DWF is another interface for Revit, denoted (Dwf).

- *Structural (with Revit Structure):* Revit Structure (Dir), ROBOT (Dir), and RISA structural analyses (IFC), BIM ME S.A.R.L. ETABS Link, SismiCAD for FEA analysis, Graitec's Advance and ARCHE, Fastrak Building Designer, StruSoft FEM-Design, SOFTEK S-Frame, STAAD-PRO via SIXchange, SOFiSTiK
- *Mechanical (with Revit MEP):* Revit MEP (Dir), HydraCAD (fire sprinklers), MagiCAD (mechanical design), QuantaCAD (mechanical laser scanning for as-builts), TOKMO (COBie facility operators handover—see Chapter 3)
- *Energy and environmental:* Ecotect, EnergyPlus, IES all indirect, Green Building Studio via gbXML

- *Visualization:* Mental Ray (Dir), 3D Max (Dir), Piranasi
- *Facility management:* Autodesk FMDesktop® (Dwf), Archibus (IFC)

Revit interfaces with AutoCAD Civil 3D for site analysis, Autodesk Inventor for manufacturing components, and with LANDCADD for site planning. It interfaces with US Cost, Cost OS by Nomitech, Innovaya, and Sage Timberline and also with Tocoman iLink for quantity takeoff for cost estimation. Innovaya also provides 4D simulation links with Primavera and MS Project schedules. Revit also supports links to Autodesk Navisworks through DWF. VICO Office supports both scheduling and quantity takeoffs. Revit has links with specifications to e-SPECS® and BSD SpecLink through the BSD Linkman mapping tool.

Revit is able to import models from SketchUp, AutoDesSys form•Z®, McNeel Rhinoceros®, Google™ Earth conceptual design tools, and other systems that export DXF files. Previously, these were visible but not referencable. They are now referencable in Version 2011 (“referencable” here means that users can select points on the objects, allowing dimensionally accurate referencing, rather than visual dimensional coordination).

Revit Architecture supports the following file formats: DWG, DXF, DGN, SAT, DWF/DWFX, ADSK (for building component), html (for area report), FBX (for 3D view), gbXML, IFC, and ODBC (Open DataBase Connectivity).

Revit is a strong platform, especially because of its range of supporting applications.

*As an environment:* Autodesk earlier invested in Web server capabilities, such as Buzzsaw and Constructware. These existed from the 1990s using file-level support, with no visible strategy to support multiple platforms.

Revit carries object IDs and seems to manage them well. However, version and change information is carried at the file level, not at the object level. This limits synchronization of objects with different views in different files. Revit is a platform but not a BIM environment. It needs to be able to manage objects, similar to ArchiCAD’s DELTA Server capability, if it is to support large-scale BIM environments (for more detail see Chapter 3, Section 3.5).

**Revit’s strengths:** As a design tool, Revit 2011 is strong; it is intuitive; its drawing production tools are excellent. However, many designers wishing to go beyond the built-in objects’ limitations use other tools to design in a more freeform manner, and then import the results into Revit for production modeling. Revit is easy to learn and its capabilities are organized in a well-designed and user-friendly interface. It has a very broad set of object libraries, developed both by themselves and by third parties. Because of its dominant market position, it is the preferred platform for direct link interfaces with other BIM

tools. Its bidirectional drawing support allows for information updates and management from drawing and model views, including schedules. It supports concurrent operation on the same project. Revit includes an excellent object library (SEEK) that supports a multiuser interface.

**Revit's weaknesses:** Revit is an in-memory system that slows down significantly for projects larger than about 300 megabytes. It has a few limitations on parametric rules. It also has only limited support for complex curved surfaces. Lacking object-level timestamps, Revit does not yet provide needed support for full object management in a BIM environment (see Chapter 3, Section 3.5).

### 2.6.2 Bentley Systems

Bentley Systems offers a wide range of related products for architecture, engineering, infrastructure, and construction. Their architectural BIM tool, Bentley Architecture, introduced in 2004, is an evolutionary descendant of Triforma, an earlier product. This review is from the perspective of Bentley Architecture. Currently, Bentley Architecture is in version V8i-08.11.07.80. It runs on top of Microstation V8.i. These run on both 32- and 64-bit processors. Bentley is a major player in the civil engineering and infrastructure marketplace.

*As a tool:* As a building modeling and drawing production tool, Bentley has a standard set of predefined parametric objects (see Table 2-1). These have relations between each other. The predefined parametric objects can only be extended through the MDL Application Programming Interface (API). Bentley also supports custom parametric objects, using the Parametric Cell Studio module; Global- or Assembly-level parametric modeling is supported by Generative Components. Each of these different toolsets has objects with different behavior and cannot support relations with objects generated by a different toolset. Bentley has good freeform B-spline surface and solid modeling capabilities. Its Luxology integrated rendering engine is fast and provides high-quality renderings and animations. For drawing production, 2D detailing and annotation on a 3D model section are well supported. For drawing editing, the predefined objects are bidirectional, but the other objects must be edited in the model to be updated. Its drawing capabilities are strong, showing actual line weights and text. It is easy to add properties to object classes. Its user interface has good features: drag-over operator hints, a smart cursor, and user definable menu setups. Bentley Architecture, with its various modules, is a large system, with lots of functionality but is less easy to access and become proficient in. Bentley Architecture supports import of external objects and clash detection.

*As a platform:* Bentley Microstation platform applications are file-based systems, meaning that all actions are immediately written to a file and result in



lower loads on memory. The system scales well. In addition to its base design modeling tools, Bentley has a large array of additional systems, many of which acquired in support of its civil engineering products. These include:

- Bentley Speedikon Architectural
- Bentley PowerCivil
- RAM Structural System
- RAM Steel
- RAM Frame
- RAM Connection
- RAM Foundation
- RAM Concrete
- RAM Elements
- RAM Concept
- GEOPAK Civil Engineering Suite
- Bentley Building Electrical Systems V8i for AutoCAD
- Facility Information Management
- ConstructSim
- Bentley PowerRebar
- Bentley Rebar
- ProConcrete
- STAAD.Foundation
- STAAD.Pro
- Bentley Building Mechanical Systems
- Bentley Tas Simulator
- Hevacomp Dynamic Simulation
- Hevacomp Mechanical Designer

Some of these products were acquired by purchasing small third-party companies and have only limited compatibility with others within the same platform. Thus a user may have to convert model formats from one Bentley application to another. User cognition sometimes must change because user interface conventions also vary.

Primavera and other scheduling systems can be imported and grouped with Bentley objects for 4D simulation. Bentley Architecture interfaces include: DWG, DXF, PDF, U3D, 3DS, Rhino 3DM, IGES, Parasolid, ACIS SAT, CGM, STEP AP203/AP214, STL, OBJ, VRML, Google Earth KML, SketchUp, Collada, and ESRI SHP. Its public standard support includes IFC certification,

CIS/2 STEP, and SDNF. Bentley products are extensible. It supports user-defined Macros, Microsoft (VBA) .NET, C++, C#, and Bentley MDL.

*As an environment:* Bentley offers a well-developed and popular multi-project server, called ProjectWise (see Chapter 3, Section 3.5.3). It supports replication of files to a prearranged set of local sites, managing the consistency of all files. It is file- and not object-based. It supports links to manage relationships between DGN, DWG, PDF, and Microsoft Office documents. Bentley supports Object IDs and timestamps and their management on round-trips.

***Bentley System's strengths:*** Bentley offers a very broad range of building modeling tools, dealing with almost all aspects of the AEC industry. It supports modeling with complex curved surfaces, including Bezier and B-splines. It includes multiple levels of support for developing custom parametric objects, including the Parametric Cell Studio and Generative Components. Its parametric modeling plug-in, Generative Components, enables definition of complex parametric geometry assemblies and has been used in many prize-winning building projects (see Chapter 9). Bentley provides scalable support for large projects with many objects. It provides multiplatform and server capabilities.

***Bentley System's weaknesses:*** Bentley's large product offerings are partially integrated, at the data consistency and user interface levels. It thus takes more time to learn and navigate. Its heterogeneous functional modules include different object behaviors, further adding to learning challenges. The weaknesses in the integration of its various applications reduce the value and breadth of support that these systems provide individually.

### 2.6.3 ArchiCAD

ArchiCAD is the oldest continuously marketed BIM application for architectural design. Graphisoft, the parent company, began marketing ArchiCAD in the early 1980s. Headquartered in Budapest, Hungary, Graphisoft was acquired in 2007 by Nemetschek, a German CAD company popular in Europe, with strong civil engineering applications. The current version of ArchiCAD is Release 14.0. ArchiCAD supports the Mac platform in addition to Windows. ArchiCAD is a 32-bit application that runs on both 32- and 64-bit versions of the Windows or the Mac Snow Leopard OS.

*As a tool:* ArchiCAD's user interface is well crafted, with smart cursors, drag-over operator hints, and context-sensitive operator menus. Its model generation and ease of use is loved by its loyal user base. Drawing generation in ArchiCAD is automatically managed by the system; every edit of the model is automatically placed in document layouts; details, sections, and 3D images can be easily inserted into layouts. Drawings are treated as reports and are not bidirectional. As a parametric modeling tool, ArchiCAD incorporates a very

broad range of predefined parametric objects. It includes modeling capabilities for site planning, for interiors, and provides strong space planning capabilities. In addition, there are 31 external Web sites that define both static and parametric objects for ArchiCAD (the majority are from Europe).

It supports the generation of custom parametric objects through its Geometric Description Language (GDL) scripting language, which relies on CSG-type constructs and a Visual BASIC-like syntax. It contains extensive object libraries for users, organized by systems: precast concrete, masonry, metals, wood, thermal and moisture protection, plumbing, HVAC, electrical, and so forth. Its user-defined parametric modeling has some limitations; its sketch tool and parametric rule generation do not support algebraic expressions or conditionals. Existing object classes can be extended and customized using GDL. It also has an Open Database Connectivity (ODBC) interface. Global grids or controls are possible but complex. It can depict and reference shapes made with complex curved surfaces, but these are not ArchiCAD typed objects and cannot be locally edited. When ArchiCAD was acquired by Nemetschek, it strengthened its design focus, releasing its early move into construction management with Vico.

*As a platform:* ArchiCAD has links to multiple tools in different domains. Some are direct links through GDL and others are through IFC. These are denoted (GDL) and (IFC), respectively:

- *Structural:* Tekla (If), Revit Structure (If), Scia Engineer (Dir) SAP & ETABS (IFC), Fem-Design (IFC), AxisVM (IFC)
- *Mechanical:* Graphisoft MEP Modeler (IFC), AutoCAD® MEP (IFC), Revit® MEP (IFC)
- *Energy and Environmental:* Graphisoft EcoDesigner (GDL), ARCHIPHISIK (IFC), RIUSKA (IFC), Green Building Studio, Ecotect, EnergyPlus, IES
- *Visualization:* Artlantis and LightWork Design for rendering, Maxon Cinema 4D for animation and freeform modeling
- *Facility management:* OneTools and ArchiFM

ArchiCAD's home Web site provides tutorials for carrying out particular IFC exchanges, used in some of these interfaces. Other tools include Virtual Building Explorer 3D, a navigation tool. It also supports direct interfaces with several external tools, including Google SketchUp import Tocoman iLink, and Express for quantity takeoffs for costing and scheduling.

Recently, ArchiCAD has further strengthened its interactions with IFC and provides good bidirectional exchange. Its IFC exchange functions include object classification, filtering by object types, and object-level version management.

*As an environment:* ArchiCAD recently expanded its Teamwork/BIM Server backend repository, which comes with the ArchiCAD platform. ArchiCAD has addressed file exchange and design coordination by developing a smart update capability, called DELTA Server, that tracks reads and writes to its BIM Server repository. The checkouts are directly controlled by the user to access those objects, or regions of the project of interest. Updates to the server, however, are checked against what was exported and only modified objects (newly created, modified, or deleted) are passed back to the server on updates. This greatly reduces the size of updates and minimizes the time to make an update. These are managed using Object IDs, and timestamps are updated when changes are made, providing the opportunity to track object history throughout the lifetime of the project. See Chapter 3, Section 3.5.1 for more detail.

***ArchiCAD's strengths:*** ArchiCAD version 14 has an intuitive interface and is relatively simple to use. It has large object libraries and a rich suite of supporting applications in design, building systems, and facility management. It can be used in all phases except fabrication detailing. Its server capabilities facilitate effective project collaboration and begin to support object-level design coordination, ahead of the capabilities of other systems. It is also supported on the Mac platform.

***ArchiCAD's weaknesses:*** It has some minor limitations in its custom parametric modeling capabilities. While ArchiCAD is an in-memory system and can encounter scaling problems with large projects, it has effective ways to manage large projects, including its DELTA Server capability.

#### 2.6.4 Digital Project

Developed by Gehry Technologies, Digital Project (DP) is an architectural and building customization of Dassault's CATIA, the world's premier parametric modeling platform for large systems in aerospace and automotive industries. DP requires a powerful workstation to run well, but it is able to handle even the largest projects. It runs on 32- and 64-bit hardware and Windows XP, Vista and Windows7 OS. Like most BIM tools, it relies heavily on an OpenGL Graphics board. The current version is V1, R4, SP 7.

*As a tool:* DP is a complex tool which is learned in small steps. Its smart cursor presents selection options. Online documentation is readily available. Menus are customizable. As a parametric modeler, DP supports both global parameters to define object classes and assemblies and local rules and relations to be maintained between objects. Its rules for defining objects are complete and general. It is excellent in developing complex parametric assemblies, such as for dealing with fabrication issues. Subtypes of an object class can be generated and their structure or rules elaborated. Curved surface modeling is excellent,

as befits a tool whose major users include automobile designers. Until the third release, DP did not include built-in base objects for buildings. Users could reuse objects developed by others, but these were not supported by DP itself. The currently provided objects shown in Table 2–1 are also available for modification. DP is complex and has a steep learning curve. It has good interfaces for importing and exporting object data to spreadsheets and XML. It continues to expand its IFC capabilities. Like most applications, annotations in DP are associative with a drawing view and are not bidirectional with the model. Drawings are treated as annotated reports. DP supports clash detection. DP's Knowledge Expert provides rule-based checking that can augment the rules used in defining shapes, but can apply between objects in different parametric trees.

*As a platform:* Digital Project is file based and very scalable. The One Island East case study in Chapter 9 provides an example of DP's ability to model every part of a 70-story office tower. The logical structure of CATIA involves tool modules called *Workbenches*. DP comes with several workbenches in addition to the Architectural and Structures Workbench: Imagine & Shape is a fully integrated freeform sketch design tool, based on CATIA, Knowledgeware supports rule-based checking of design; the Project Engineering Optimizer allows for easy optimization of parametric designs based on any well-defined objective function; and Project Manager for tracking parts of a model and managing their release. These are sophisticated tools with major potential benefits, but which require significant technical knowledge for effective use. It also includes capabilities for mechanical, electrical, and plumbing layout in its MEP Systems Routing. Other products organized as CATIA Workbenches can also be easily integrated. Of note is Delmia, a Monte Carlo simulation system allowing assembly and fabrication modeling and assessment. Its user interface is consistent across Workbenches. In addition to the integrated workbenches, DP has interfaces with Ecotect for energy studies, 3DVia Composer for documentation production, and 3DXML for lightweight viewing. It has links to Microsoft Project and Primavera Project Planner for scheduling, and ENOVIA for project lifecycle management. DP is built to define new object and family classes. It supports Visual BASIC scripting and has a strong API which uses .NET for developing add-ons. It has the Unifomat<sup>®</sup> and Masterformat<sup>®</sup> classifications embedded, which facilitates integration of specifications and cost estimating. It supports the following exchange formats: CIS/2, IFC Version 2x3, SDNF, STEP AP203 and AP214, DWG, DXF<sup>™</sup>, VRML, TP, STL, CGR, 3DMAP, SAT, 3DXML, IGES, STL and HCG.

*As an environment:* DP was designed as a platform, with a suite of tools tailored to integrate manufactured product design and engineering. It supports concurrent users, with the open source SVN version control manager. It has additional related features that provide integration at the environment level.

Enovia is the major Dassault PLM (Product Lifecycle Management) product (see Chapter 3). DP carries multiple timestamps and a GUID at the object level for supporting object-level version management.

**Digital Project's strengths:** It offers very powerful and complete parametric modeling capabilities. It is able to directly model large, complex assemblies for controlling surfaces, features, and assemblies. It can support fabrication. Digital Project relies on 3D parametric modeling for most kinds of detailing. It is a complete solution, at the platform level. It has a powerful set of integrated Workbench tools.

**Digital Project's weaknesses:** DP requires a steep learning curve, has a complex user interface, and high initial cost. Its predefined object libraries for buildings are limited, as are external third-party object libraries. Drawing capabilities for architectural use are not fully developed.

### 2.6.5 Vectorworks

Vectorworks began as MiniCad, developed by Diehl Graphsoft in 1985. MiniCad supports users in a diverse set of design markets, in stage lighting theater and set design, and in exhibit design. Vectorworks has a marine division that is a player in CNC machining forms for shipbuilding. It began as an Apple Computer Mac CAD system, adapting to Windows in 1996. Diehl Graphsoft was acquired by Graphisoft in 2000 and its product name soon was changed (to eliminate the similar naming) to Vectorworks. It has always stressed strong customer support and a strong worldwide user base, targeting smaller firms. In 2009, it adopted Parasolid geometry engine for its core geometric modeling platform; Vectorworks previously had parametric capabilities similar to Architectural Desktop. Now its parametric modeling is similar to others, but with the ease of use and fine-grained user-friendliness for which it has long been noted.

*As a tool:* Vectorworks provides a very wide variety of tools, organized as separate products but packaged together. These include:

*Architect*—for architectural and BIM applications

*Designer*—for product design, also has an interiors module

*Landmark*—a landscaping tool, with access to both 2D and 3D plant libraries

*Spotlight*—lighting simulation for venues and event simulation

*Machine design*—provides machine design, with parametric classes of machine parts, gears, cams, pulleys, and so forth, and also numerical control machining capabilities

*Renderworks*—Vectorworks' rendering tool

These different products provide a wide range of functionality, all with an integrated user interface and style, with drag-over operator hints, smart cursor, content-sensitive operator display, and customizable menus. The functionality of some of these products is overlapping. Vectorworks' drawing capabilities associate drawn section annotations with model projections. Annotations and dimensions are not yet associated with the 3D object projections, requiring extra care in checking the drawing view's consistency with the model. Vectorworks has a reasonable set of object libraries to import and use. Its NURBS surface modeling is very good. It supports customizing its predefined object classes and also supports new object definition, mostly using its API or Vectorscript scripting language. It has incorporated a Design Constraint Manager from Siemens PLM that facilitates the management of dynamic dimension-shape interaction. Currently, the Constraint Manager is limited to 2D applications, but can address extrusion profiles and many other such uses. Attributes are carried in a project database and associated with objects, for use when needed.

*As a platform:* Vectorworks is an in-memory system. It comes in both 32- and 64-bit versions, for both the Mac and PC. Like many other systems, it uses Workgroups to partition models into practical model subsets, to deal with scale problems and to allow concurrent access to different parts of a project. Its user interface across its products is well integrated.

Some interfaces to other applications are direct links but most are through IFC. These are denoted (IFC).

- *Structural:* Revit Structure (IFC), Scia Engineer (IFC), Tekla (IFC), Nemetschek Allplan
- *Mechanical:* Vectorworks includes many of the objects needed for parametric MEP layouts, such as ductwork, piping, and cable trays. It also supports interfaces with MagiCad (IFC).
- *Energy and environmental:* Vectorworks has a link to IES and its wide suite of tools; other mechanical applications are communicated through IFC
- *Visualization:* Uses Renderworks (IFC) as its internal rendering engine and Artlantis as its external high-end one; provides ESP-vision link for venue and event lighting simulation; also supports interface to Maxon Cinema 4D

As stated, Vectorworks' Marine Division is a major player in CNC cutting forms for shipbuilding. The Mac version of Vectorworks can interact with

TouchCad, an unfolding and skinning tool. Other tools include Virtual Building Explorer 3D, a navigation tool. Vectorworks relies on exporting to spreadsheets for quantity takeoffs and cost estimation. It also supports direct interfaces with several external tools, including Google SketchUp import. Vectorworks has a Visual Basic–like scripting language and an open API. Its exchange formats include DXF/DWG, IGS, SAT, STL, X\_T, 3DS. Vectorworks has strengthened its interactions with IFC and provides good bidirectional exchange. Its IFC functions include object classification, assignment of Property sets and owner/history data. Its IFC (2x3) exchange capabilities have been tested with ArchiCAD, Bentley Microstation, AutoCAD Architecture, Revit, Solibri Model Checker™, and Navisworks®.

*As an environment:* Vectorworks has focused on its support for certain design tasks in different markets. It has a limited association with Siemens PLM, but it makes no claims as a BIM environment. Objects do not carry or manage GUID or version information.

### 2.6.6 Tekla Structures

Tekla Structures is offered by Tekla Corp., a Finnish company founded in 1966 with offices worldwide. Tekla has multiple divisions: Building and Construction, Infrastructure, and Energy. Its initial construction product was Xsteel, which was introduced in the mid-1990s and grew to be the most widely used steel detailing application throughout the world. It is largely file-based and scales well. It supports multiple users working on the same project model on a server. It does not currently support B-spline or NURBS surfaces.

*As a tool:* In the early 2000s, Tekla added precast concrete design and fabrication-level detailing for structural and architectural precast. In 2004 the expanded software product was renamed Tekla Structures to reflect its expanded support, including for steel, precast concrete, timber, reinforced concrete, and for structural engineering. Recently, it has added Construction Management capabilities. It is a platform supporting a growing range of products. In addition to full detail editing stations, it also offers Engineering, Project Manager, and Viewing stations. All of these tools provide the functionality needed for fabrication and automated fabrication. It supports a Windows 7–like user interface, with drag-over operator hints, smart cursor, and user-configurable menus. It has good functionality to customize existing or create new parametric objects. Nevertheless, it is a complex system with rich functionality that takes time to learn and keep abreast of.



*As a platform:* Tekla offers interface support for a wide range of other applications:

<b>Application</b>	<b>Company</b>	<b>Capabilities</b>
AxisVM	Inter-VCAD Kft	CNC fabrication
CYPECAD	Cype	Structural design and analysis of reinforced concrete
Diamonds	Buildsoft	Structural design and analysis
Fastrak	CSC	Structural design and analysis
FEM Design	StruSoft	Structural design and analysis
MidasGen	MIDAS	Structural design and analysis
ModeSt	Tecnisoft	Structural design and analysis
NISA	Cranes Software International Ltd.	Structural analysis
PowerFrame	Buildsoft	Structural analysis
RFEM	Dlubal	Structural analysis
Robot Millenium	Autodesk	Structural analysis
RSTAB	Dlubal	Structural design and analysis
SAP2000	Computers & Structures, Inc	Structural analysis
SCIA	Nemetschek	Structural design and analysis
S-Frame	CSC/Softek	Structural analysis
STAAD	Bentley	Structural design and analysis
STRUDS	SoffTech	Structural design and analysis
Trimble LM80	Trimble	Jobsite layout, survey equipment
BuildSite	BuildSite	Product and technical information for manufacturers and distributors
Meridian Prolog Converge	Meridian	Project management

Tekla has an open application programming interface. It also supports a very broad range of exchange formats, some those native to other applications, as shown in Table 2–3:

*As an environment:* Tekla supports concurrent user access to the same project, allowing reservations at the object or higher aggregation of objects level. It carries object IDs and timestamps, supporting object-level management.

***Tekla Structures' strengths:*** Its versatile ability to model structures that incorporate a wide range of structural materials and detailing; its ability to support very large models and concurrent operations on the same project and

**Table 2-3** Formats Supported by Tekla

<b>Format</b>	<b>Import</b>	<b>Export</b>
AUTOCAD (.dwg)	X	X
AUTOCAD (.dxf)	X	X
BVBs (.abs)		X
Cadmatic models (.3dd)	X	
Calma plant design system (.calma)	X	X
CIS/2 IpM5/IpM6 analytical, design, manufacturing (.stp, .p21, .step)	X	X
DsTV (.nc, .stp, .mis)	X	X
Elematic Eliplan, Elipos (.eli)	X	X
EpC		X
Fabtrol Kiss file (.kss)		X
Fabtrol Mis Xml (.xml)	X	X
GTsdata priamos		X
High level interface file (.hli)	X	X
HMs (.sot)		X
IFC2x/IFC2x2/IFC2x3 (.IFC)	X	X
IFCXML2X3 (.xml)	X	X
IGES (.iges, .igs)	X	X
Intergraph parametric modeling language (.pml)		X
Microsoft project (.xml)	X	X
Microstation (.dgn)	X	X
Oracle Primavera p6 (.xml)	X	X
Plant Design Management system (.pdms)		X
SAP, Oracle, oDBC, etc.	X	X
STAAD ASCii file (.std) in out	X	X
Steel Detailing Neutral Format (.sdf, .sdnf)	X	X
Steel12000		X
STEP ap203 (.stp, .step)	X	
STEP ap214 (.stp, .step)	X	X
Trimble IM80 (.txt, .cnx)		X
Unitechnik (.uni)	X	X

with multiple simultaneous users. It supports user-defined parametric custom component libraries, including customization of its provided objects.

***Tekla Structures' weaknesses:*** While a powerful tool, its full functionality is quite complex to learn and fully utilize. The power of its parametric components is impressive and, while a strength, requires dedicated operators who must develop high levels of skill. It is able to import objects with complex multicurved surfaces from outside applications, and these can be referenced but not edited. It is also relatively expensive.

### 2.6.7 DProfiler

DProfiler is a product of Beck Technologies. It is based on a parametric modeling platform acquired from Parametric Technologies Corporation (PTC) in the late 1990s, after PTC decided not to enter the AEC market. DProfiler is an application and platform that has evolved from the software acquired from PTC.

DProfiler functionality is unique; it addresses conceptual design from a cost of construction, and, to a degree, an operating cost basis. It supports quick definition of the conceptual design of given building types, based on the room types, and building structural and site parameters. The high-level components of a project are: Site: soils, parking, detention ponds; Massing: cladding, features, mechanical, slabs, rooms. These are building model objects that carry links to the cost definitions. A concept-level model can be laid out in an easy 3D sketch manner, using intuitive editing operations. A building can be composed as a set of spaces, floor by floor, or alternatively as a shell that is then decomposed, into floors that are assigned spaces or some mixture of the two. The site plan can be an imported terrain model or Google Earth segment. Each of these can be defined in little or great detail, using defaults, or overriding them if desired.

Defaults are set up for different building types, using the RS Means Masterformat 16 divisions, or further down to line-item detailed categories, or alternatively to Timberline's more detailed ones. Each object, such as wall or slab is associated with an assembly cost class. Objects can be changed from one construction type to another without necessarily changing the geometry. This means that a cost estimator has almost complete control of the project costing, defining types of slabs, and details of cladding and construction. It has increasingly detailed site development definition and costing. Cost parameters are carried as fixed units for the building type or location, while others are under explicit user control (such as the type of films on glazing or number of fume hoods in a laboratory), while the building geometry defines the spatial properties. The design model is thus geometrically simple and can be simple or complex from a cost standpoint, where the design intent is defined by the associated cost categories. Thus the strength of the system is the articulation

of intent in the cost-estimating side, organized hierarchically as Components, Collections, Assemblies, and Line Items. These multiple levels allow contractors or other users to map to their own cost databases, if that is desired.

The resulting cost estimates are detailed, based on quantity of materials in place, that start out being estimates, but that can be tracked downstream as the project is detailed, then constructed, to compare with the actual quantities and costs for quality assurance. In addition, it provides a full economic cash-flow development proforma for the project, optionally including occupancy and operation. The cost estimating database accessed by DProfiler is centralized and maintained by the Dallas office.

DProfiler supports a range of graphical inputs for defining a project, for example, DGN, DXF, PDF, DWF. It also supports output to eQuest for energy analysis, used to estimate operating costs, and output to XLS spreadsheets and various image formats. At the time of this review (Fall 2010), Beck also has a beta version for importing into Revit, allowing a full mapping of DProfiler entities and composition into Revit object families and instances. DProfiler can also fully map its cost estimate data for a Revit project to Timberline. Informally teaming with Innovaya, DProfiler supports a user link between the imported Revit project model with the matching Timberline cost model, allowing tracking downstream as the project is further developed. The Hillwood-Beck Multiuse Building case study (discussed in Chapter 9) presents an example of DProfiler's use.

***DProfiler strengths:*** DProfiler functionality allows it to be easily adapted to almost any building type, based on costing of assemblies and line items. With its interface to Revit, it will have strong transfer capabilities downstream. Its strength is in the value analysis of various concept designs based on a wide range of construction specifications and their associated cost estimates. Some case studies show that a well-developed DProfiler project is reliable to within 5 percent of construction costs, and it has supported project models that have come within 1 percent of project costs. Its ability to generate detailed economic assessments on a conceptual-level project is powerful and unique.

***DProfiler weaknesses:*** DProfiler is not a general purpose BIM tool. Its major purpose is financial evaluation of a construction project, with financial exploration of alternative finishes and system choices, usually without modeling them geometrically. Once a model is complete, its interface to support full development is limited currently to Revit.

### 2.6.8 AutoCAD-Based Applications

Autodesk's premier building application on the AutoCAD platform is Autodesk Architecture. Previously called Architectural Desktop (ADT), it was

Autodesk's original 3D building modeling tool prior to the acquisition of Revit. Both ADT and AutoCAD are integrated. It is based on solid and surface modeling extensions for AutoCAD and provides a transition from 2D drafting to BIM. It has a predefined set of objects and limited sets of rules for those objects. They are parametric within the defined object or assembly (like a stair or roof). It provides some of the functionality offered by parametric tools, including the ability to make custom objects with adaptive behaviors. External Reference Files (XREF) are useful for managing large projects. Drawing Space in AutoCAD is linked to Model Space from the 3D model, and in current interpretation, provides one-way links from the model to the annotated drawings. The model views are simple orthographic projections, with limited view management. It relies on AutoCAD's well-known capabilities for drawing production. Interfaces include: DGN, DWG, DWF™, DXF™, and IFC. Its programming extensions include: AutoLISP, Visual Basic, VB Script, and ARX (C++) interfaces.

AutoCAD has different versions for different types of user. These include versions for Architecture, MEP, Electrical, Civil 3D, P&ID, and Plant 3D. These have different objects for each user type. AutoCAD Architecture objects include: Walls, Column Grids, Columns, Beams, Curtain Walls, Spaces, Roofs, Stairs, Multiview Blocks, and Mass Elements. AutoCAD MEP objects include: Cable Tray, Cable Tray Fitting, Conduit, Conduit Fitting, Duct, Duct Custom Fitting, Duct Fitting, Duct Flex, Hanger, Multiview Part, Panel, Pipe, Pipe Custom Fitting, Pipe Fitting, and Pipe Flex.

Third parties are encouraged to use AutoCAD as a platform and to develop new sets of objects in different AEC domains. This has led to a worldwide developer community. These include companies such as Computer Services Consultants (CSC), which offers a number of structural design and analysis packages; AEC Design Group, which offers CADPIPE; COADE Engineering Software, that offers piping and plant design software; SCADA Software AG, that develops control system software; and other companies that produce 3D applications for piping, electrical system design, structural steel, fire sprinkler systems, ductwork, wood framing, and others.

***AutoCAD-based applications' strengths:*** Ease of adoption for AutoCAD users because of user interface consistency; easy use because they build upon AutoCAD's well-known 2D drafting functionality and interface. There is an extensive API with numerous programming languages for developing new applications; well supported with appropriate Software Development Kits (SDK).

***AutoCAD-based applications' weaknesses:*** Their fundamental limitations are that they are not parametric modelers that allow nonprogrammers

to define new objects (without API-level programming), object rules, and constraints; they have limited interfaces to other applications; their use of XREFs (with inherent integration limitations) for managing projects; they are an in-memory system with scaling problems if XREFs are not relied upon; and they need to propagate changes manually across drawings sets.

---

## 2.7 LIGHTWEIGHT MODELING APPLICATIONS

Each of the above platforms consists of a building model and one or more applications that can create, edit, and translate the model data for different uses. In addition, we report here on two widely available lightweight building models and applications which have their own uses. They are 3D PDF (Portable Document Format), developed by Adobe®, and DWF (Design Web Format), developed by Autodesk®. These two building model formats are not for creating building model information, but rather for “publishing” information to support various workflows. That is, these Web formats provide design and engineering professionals with a way to package, distribute, and review the building model information, with markup and query capabilities; but not to enable modification of the model information. The widespread availability of these building model formats is likely to lead to their playing a useful role in the exchange and viewing of project information. Following is a brief overview of some of the features of these formats:

- ***Generic, nondomain specific and extensible schema:*** These formats do not have domain-specific schemas, rather they have schemas with general classes of entities, from geometric polygonal entities and solid entities to markup objects and sheet objects. They are designed to meet the broad needs of engineering and design disciplines including manufacturing and the AEC industry. PDF was originally designed for exchange of text- and image-based documents and has been extended to include support for U3D (Universal 3D) elements. The DWF schema was designed specifically for exchange of intelligent design data and is based upon Microsoft’s XML-based XPS (XML paper specification) format and extensions, allowing anyone to add objects, classes, views, and behaviors. Although PDF is an ISO standard, neither DWF nor the 3D PDF extensions are ISO standards.
- ***Embedded views of the project information:*** Both formats represent the model data and views of that data. Data views include 2D plot views, 3D model views, or raster image views; each is separate and not

interlinked. The 2D and 3D model representations are separately fully navigable, selectable, and support queries. They include object meta-data, but object parameters cannot be edited.

- **Widely available viewing tools:** Both formats are distributed with free, publicly available viewers.
- **High fidelity, accuracy, and precision:** Both formats were designed for plot-capable printing with a high level of accuracy and precision.
- **Highly compressible:** Both formats are optimized for portability and are highly compressed.

The three primary applications using these two formats are:

**Adobe Acrobat 9 Pro Extended** is a free 3D PDF viewer; It supports a dynamic and viewable 3D object or animation to be embedded in a document. Supports model comparison.

**Autodesk Design Review** is a free downloadable viewer to support review, checking, and other forms of collaboration. It supports 2D drawings and 3D models converted to DWF. Models can be spatially reviewed by fixed, walking or flying through them; views may be fixed orthogonal to various surfaces or by cutting sections through the project. Distances and angles may be derived between object surfaces. Queries by object names are also supported, with the object names returned, which when selected are highlighted in the view. Two-dimensional documents may be rotated, and markups may be applied to any point on surface, for recording review comments. Reports with markups are easily generated. A digital signature is provided, allowing the signature to check if changes have been made to the file since the signature was applied.

**Streamline** is a Web-based reviewer developed to support the manufacturing market for single parts or assemblies. It provides lightweight geometrical modeling and some data generated through DWF publisher. It incorporates a secure socket layer with client. DWF files are uploaded to a server, and can be reviewed by any approved (password protected) user. Autodesk manages the server farm.

---

## 2.8 CONCLUSION

Object-based parametric modeling is a major change for the building industry that is greatly facilitating the move from a drawing-based and handcraft technology to one based on digitally readable models that can generate consistent drawings, schedules, and data; interface to address issues of design performance, construction, and facility operating information. Parametric modeling

facilitates the design of large and complex models in 3D but imposes a style of modeling and planning that is foreign to most users. Like CADD, it has been most directly used as a documentation tool separate from designing. A growing number of firms, however, use it directly for design and for generating exciting results. Some of these uses are taken up in Chapter 5, and the case studies in Chapter 9 provide further examples.

The ability to extract geometric and property information from a building model for use in design, analysis, construction planning, and fabrication, or in operations, is starting to have large impacts on all aspects of the AEC industry; many of these are discussed in the succeeding chapters. The full potential of this enabling capability will not be fully known for at least another decade, because its implications and new uses are being discovered incrementally. What is currently known is that object-based parametric modeling resolves many of the fundamental representational issues in architecture and construction geometric modeling and allows quick payoffs for those transitioning to it, even with only partial implementation. These early payoffs include a reduction in drawing errors due to the built-in consistency of a central building model, improved engineering productivity, and the elimination of design errors based on spatial interferences. Because the models are 3D and much closer to everyday reality, they facilitate communication among the actors in a project: owner, architects and their consultants, contractors, fabricators, and potentially, operators.

While object-based parametric modeling has had a catalytic influence on the emergence and acceptance of BIM, it is not synonymous with BIM design tools or the generation of building models. There are many other design, analysis, checking, display, and reporting tools that can play an important role in BIM procedures. Many information components and information types are needed to fully design and construct a building. Fundamentals of these other types of data, dealing with relations and attributes, have not been as fully developed as the geometry component nor have they been standardized. Many types of software can facilitate the development and maturing of building information modeling. The BIM design tools and platforms considered here, and the BIM environments considered in the next chapter, are only the newest in several generations of tools, but are already proving to be revolutionary in their impact.

### **Acknowledgment**

The reviews of the different BIM tools were augmented from reviews that were undertaken by the following people: Jaemin Lee, Maher El-Kaldi, Josh Oakley, Hugo Sheward, and Frank Wang. We thank them for their significant help. Any errors are the responsibility of the authors.



---

## Chapter 2 Discussion Questions

---

1. Summarize the major functionalities that distinguish the capabilities of a BIM design tool from 3D CAD modeling tools.
2. Most BIM design tools support both 3D object models as well as 2D drawn sections. What considerations should be made when determining the changeover level of detail, such as when to stop modeling in 3D and complete the drawings in 2D?
3. Why is it unlikely that a single integrated system will incorporate a unified parametric model of all of a building's systems? On the other hand, what would be the advantages if it could be achieved?
4. In what ways are some of the current popular design tools not BIM design tools? SketchUp? 3D Max Viz? FormZ? Rhino?
5. What are the essential differences between a manufacturing parametric modeling tool, such as Autodesk Inventor, and a BIM design tool, such as Revit?
6. Do you think there may be additional manufacturing-oriented parametric modeling tools used as a platform to develop BIM applications? What are the marketing costs and benefits? What are the technical issues?
7. Suppose you are a Chief Information Officer for a medium-sized architectural firm (with fewer than 25 employees). The firm specializes in school buildings. Propose an outline structure for the firm's custom object library.
8. You are part of a small team of friends who have decided to start an integrated design-build firm comprised of both a small commercial contractor and two architects. Lay out a plan for selecting one or more BIM-model creation tools. Define the general criteria for the overall system environment.



# CHAPTER 3

---

## Interoperability

---

### 3.0 EXECUTIVE SUMMARY

Multiple applications with overlapping data requirements support various tasks of design and construction. *Interoperability* is the ability to exchange data between applications, which smoothes workflows and sometimes facilitates their automation.

Interoperability has traditionally relied on file-based exchange formats limited to geometry, such as DXF (Drawing eXchange Format) and IGES (Initial Graphic Exchange Specification). Direct links based on the Application Programming Interfaces (APIs) are the oldest and still-important route to interoperability. Starting in the late 1980s, *data models* were developed to support *product* and *object model* exchanges within different industries, led by the ISO-STEP international standards effort. Data models distinguish the schema used to organize the data and the schema language to carry the data. Some translators can be from one schema language to another, for example from IFC to XML.

Two main building product data models are the *Industry Foundation Classes* (IFC)—for building planning, design, construction and management,

and *CIMsteel Integration Standard Version 2*, (CIS/2)—for structural steel engineering and fabrication. A related STEP model is ISO-15926, for life-time modeling of process plants. All three models represent different kinds of geometry, relations, processes and material, performance, fabrication, and other properties needed for design and production.

Because product model schemas are rich and redundant, two applications can export or import different information for describing the same object. The *National BIM Standard* (NBIMS) is being undertaken to standardize the data required for particular exchanges. Parallel efforts are being undertaken in Europe. As effective exchanges are being developed, it is becoming recognized that the next threshold for better design and construction management is improving *workflows*. Automation of exchanges can streamline workflows, eliminating steps.

While file- and XML-based exchanges facilitate data exchange between pairs of applications, there is a growing need to coordinate data in multiple applications through a *building model repository*. A critical aspect of BIM repositories is that they allow management of projects at the building object level, rather than at a file level. A fundamental purpose of a BIM repository is to help manage the synchronization of multiple models representing a project. BIM repositories will become a common technology for managing BIM projects in the near future.

---

### 3.1 INTRODUCTION

The design and construction of a building is a team activity. Increasingly, each activity and each type of specialty is supported and augmented by its own computer applications. Beside the capability to support geometry and material layout, there are structural and energy analyses that rely on their own building representation. A schedule of the construction process is a nongeometrical representation of the project, closely aligned to the design; the fabrication models used for each subsystem (steel, concrete, piping, electrical) are other representations with specialized detailing, in addition to others. *Interoperability* is the ability to pass data between applications, and for multiple applications to jointly contribute to the work at hand. Interoperability, at the minimum, eliminates the need to manually copy data already generated in another application. Manual copying of partial project data greatly discourages iteration during design, as required for finding best solutions to complex issues, such as structural or energy design. It also leads to errors, where manual copying inevitably leads to some level of inconsistency. It also is a great restriction to the automating of business practices. Suppose that all eBay and other e-business

could only work without personal accounts, requiring you to enter your full profile each time you used the site; tracking of your order would not be practical. The e-commerce site could not bring you special offers. Interoperability opens up new paths of automation.

People are used to geometry exchanges between applications, using translators such as DXF, IGES, or SAT. These are fairly robust; people can visually inspect the geometry for any errors and correct them. Why is building model exchange more difficult? The reality is that we have moved past the modeling of shapes and geometry to the modeling of objects—first generic and abstract ones, and later objects corresponding to real products or that will be instructions for construction. While geometry has been the main concern for drafting and CAD systems, with BIM we are now representing multiple kinds of geometry and also relations, attributes, and properties for different behaviors, as described in Chapter 2. The model, while integrated, must carry much more information than do CAD files. This is a large change and the supporting information technology methods and standards for achieving this are only incrementally being put in place.

In the last chapter, we distinguished three types of BIM applications, as tools, as platforms, and as environments. Interoperability supports different capabilities and addresses different problems in exchanges of data across these three levels. The most common and important form of data exchanges are between a BIM platform and a set of tools it can support (most common are analysis tools, such as structural or thermal analysis, or quantity takeoff, scheduling, and procurement applications). In these cases, specific portions of the platform's native data model (the data structure that the platform uses internally) are translated. The translation is realized by defining the needed model data on the platform (called a model view) and putting that data into the format needed by the tool and filling in other nonmodel information. Usually, the translation from platform to tool is one way, as the receiving tool lacks the design data or rules required to correctly update the platform's native building model. The BIM tool's results inform the platform user, and the user updates the original model. In a few cases the tool's results can be used to generate automated design changes in the platform, such as in searching through an automatically generated set of designs for those which are closest to some goal, or eliminating an error, such as automatic rerouting of mechanical equipment in response to clash detection. These types of automated changes based on a review, are likely to increase. Platform-to-tool exchange is the most fundamental form of interoperability and is supported by both direct application-to-application exchange and also through shared neutral exchange formats, such as IFC.

Platform-to-tool data exchange can be complex. Extracting the stick and node model for a structural analysis and determining the relevant loads is not yet a common automated translation, as it requires human expertise and judgment (Emkin 1988). Similarly, energy analyses have had building models specially developed for their input, but these are not defined in a model structure that a designer would use, requiring the development of a new or heavily revised model to undertake the energy analysis. These exchanges are complex because of the special geometry the tools require. Eventually, we will see robust and competent automatic translations from design-oriented models; in the meantime, interactive manual translations will be required.

More straightforward are tool-to-tool exchanges. These are limited because of the limited data available within the exporting tool. One example is the translation of a quantity takeoff (QTO) to cost estimating application. Here the QTO extracts BIM data that has multiple potential uses for cost estimating, later for purchasing and materials tracking, or maybe to associate with work packages and scheduling. Another tool-to-tool interface is the use of a lightweight geometric viewer, considered here as a BIM tool, such as Autodesk Design Review (using DWF format) or Adobe's 3D viewer (using PDF format). These tools have their own design uses in visualization and review. They are also promoted and can be used for limited application as interfaces for other tools, such as lighting simulation or clash detection. In these cases, the boundary between a design platform and a tool is fuzzy. The bottom line is that lightweight geometry viewers cannot implement design changes and cannot update the model in the platform; the information flows are one-way.

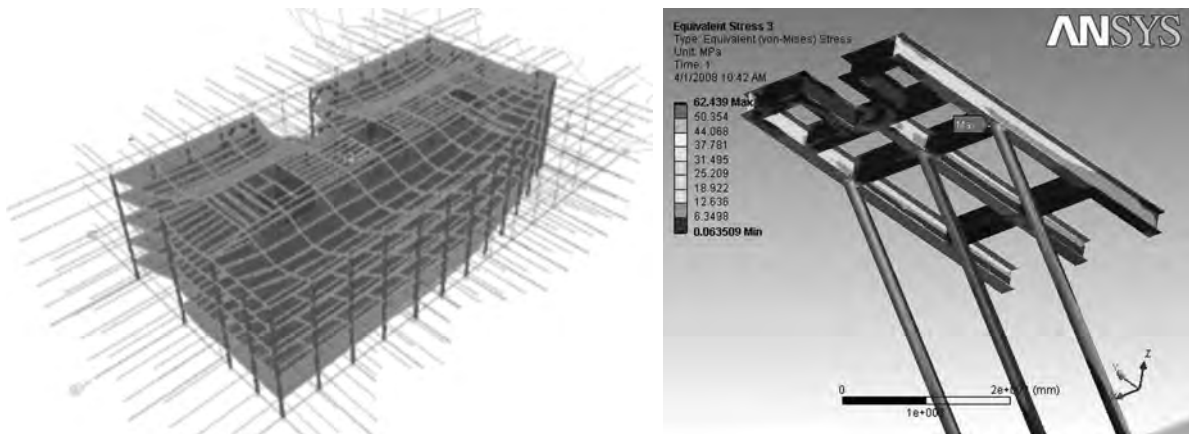
The major challenge of interoperability is platform-to-platform exchange. This includes design platforms such as ArchiCad, Revit, and Digital Project and fabrication model platforms such as Tekla, SDS/2 Structureworks, and StruCad, CADPipe, and CAMduct. Platforms not only incorporate a broad spectrum of data, they also incorporate rules that manage the objects' integrity. Consider the "building core" custom parametric assembly described in Chapter 5, Section 5.4.1. The rules for its layout and updating were developed by the architectural firm that developed it, based on the experience of producing many dozens of high-rise office buildings. While it is straightforward to pass a fixed instance of the building core object to another application, passing an editable model would require passing the rules, some embedded in spreadsheets, to the receiving platform. Today, there is only limited similarity of the rule sets supported by the different BIM platforms (as described in the Commonly Asked Questions in Chapter 2 Section 2.3.6. Similarly, a wall assembly in some BIM platforms has its own application of those rules, possibly with embedded objects such as framing, with rules applied to the framing.

In such cases, platform-to-platform exchange is not possible. It should be emphasized that the exchange of fixed shape objects and even some simple extrusions are not problems. At some point in the future, a standard vocabulary of rules may be developed, which could lead to solving this platform-to-platform exchange of parametric models.

More generally, an issue growing out of interoperability is the need to manage the multiple representations of a project, at the platform and tool levels. The need is not to just translate an architectural model to another format, but to modify or extend the model information so that it represents the design for different uses. The structural design example discussed above indicates the knowledge required to translate a physical model of a structural design into a model for structural analysis. The derivation of a structural model from a physical model involves many specialized considerations, dealing with structural codes, spans, depth of beams, the behavior of connections, and especially loading conditions. Expertise in structural engineering is required to define the analytical model of a building from its architectural incarnation (Emkin 1988). Also, the structural model may take alternative forms, usually a stick and node representation characterizing the structure's topology for transmitting its behavior (see Figure 3-1(left)). The model carries abstract representation of connection behavior, external loads, and the code requirements to address load combinations. Some particular parts of a structure, because of its geometrical or loading complexity, or their criticality to the project, may be represented as a mesh in a 3D finite element model (FEM), with a much more detailed geometry whose interfaces define a different set of nodes and element requirements (Fig 3-1(right)). This is not a solid model, but rather a packed set of cells that are able to describe their behavior within the framework of the other cells. FEM models are typically derived from solid models with significant human input. The generation of both types of structural models requires structural design expertise. And we can have two and sometimes more representations of a building's structural members.

The major point is that as changes are made to one model, the consistency of other models requires them to be reviewed and possibly updated. Currently, almost all of this updating and management is carried out manually and laboriously. Changes propagate and management of propagation is a fundamental aspect of design coordination. These are the broader issues of interoperability.

Why should architects, contractors, engineers, and fabricators be interested in interoperability and product models? Aren't these technological issues for computer scientists and software companies to resolve? Why is this chapter important to read and understand?



**FIGURE 3-1** Two different types of analytic structural models: a deformed stick model of a structure and a 3D solid finite element model of another structure.

(Waller Marine, Inc.)

Standards have played and will continue to play important roles in AEC business practice—material performance standards, graphic standards, standards for defining products, drawing set standards, classification standards, layering standards. Some standards are to help people understand each other. Since building information model standards are digital, the development of such standards also are digital. Computer scientists can and have implemented the technological framework for interoperability, by providing the languages (EXPRESS, BPMN, XML, and others are being explored) that support exchange protocols. Architects, engineers, contractors and fabricators, however, are the knowledge experts that know what the information content of an exchange should be. In AEC, no one organization has the economic clout or knowledge to define effective interoperability for the whole industry. User-defined exchange standards seem an imperative. Consider the meaning of r-values, lumens, thermal breaks, and wythe.<sup>1</sup> Different construction domains define needed terms and these are part of that field. In some ways building model exchanges deal with the varied building information with which a field works.

Interoperability, then, involves mapping specific model information from that defined for one application to the logically consistent information required for another application. In simple cases, the translation is syntactical and does not involve changes in meaning. However, many exchanges require embedded expertise that interprets the design information with one meaning to other information with other meanings. A familiar example would be translating

<sup>1</sup>A continuous vertical section of masonry one unit in thickness, typically called out on wall sections.



an architect's building model to one used for energy analysis. In that conversion, the meaning of all space boundaries dramatically changes. All building projects, by the time they are built, involve both these kinds of translations. These meanings are defined by the fields that use the data. Methods for defining these exchanges are the focus of the first part of this chapter. The second part focuses on the issues and methods for synchronizing and managing the multiple representations of a building project and the management of these heterogeneous representations.

---

## 3.2 DIFFERENT KINDS OF EXCHANGE FORMATS

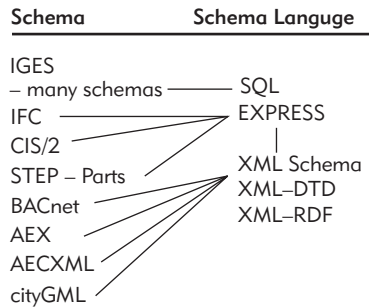
Even in the earliest days of 2D CAD in the late 1970s and early 1980s, the need to exchange data between different applications was apparent. The most widely used AEC CAD system at that time was Intergraph. A set of businesses arose to write software to translate Intergraph project files to other systems, especially for process plant design—for example, exchanging data between the piping design software and the applications for piping bills of material or pipe flow analysis.

Later, in the post-Sputnik era, NASA found that they were expending significant amounts of money paying for translators among all their CAD developers. The NASA representative, Robert Fulton, brought all the CAD software companies together and demanded that they agree on a public domain exchange format. Two NASA-funded companies, Boeing and General Electric, offered to adapt some initial efforts they had undertaken separately. The resulting exchange standard was reviewed, extended, and christened IGES (Initial Graphics Exchange Specification). Using IGES, each software company need only develop two translators (it was thought), for exporting from and importing to their application, instead of developing a translator for every pair-wise exchange. IGES was an early success that is still widely used throughout many design and engineering communities.

Recent McGraw-Hill Surveys on BIM identify interoperability as the largest issue for advanced BIM users (McGraw-Hill 2009). How do we achieve interoperability—the easy, reliable exchange of project data? In general, data exchanges between applications are based on two levels of definition, characterized in Figure 3–2. We are aware of the top-level interface that is the model *schema*, defining the meaning of the information exchanged. Initially, a file format was defined that did not separate the way information was formatted from its semantic content. IGES and DXF are examples. The separation of the schema from a more general language became a recognized advantage in the 1980s. All more recent data exchange technologies incorporate this distinction. Structured Query Language (SQL) is a prime example and the dominant

**FIGURE 3-2**

All modern exchange formats are based on a schema defined in a schema language. There are many XML schemas with different schema languages.



schema definition language for databases in the world. There are thousands of SQL schemas, mostly proprietary. The ISO-STEP-developed data modeling language, EXPRESS (Schenck and Wilson 1994) is the basis for a range of product modeling technologies and schemas, including Industry Foundation Classes (IFC) (IAI 2010) and CIMsteel Integration Standard, version 2 (CIS/2) (CIS/2 2007), as well as over 20 exchange schemas in manufacturing, ship-building, and electronics.

Another large set of exchanges are supported by XML (eXtensible Markup Language). XML is an extension to HTML, the base language of the Web. XML supports multiple handling of schemas. Some are embedded within the exchanged data and others rely on an external schema. Some XML schemas are published and public, while others are proprietary. The different XML schemas support exchange of many types of data between applications. XML is especially good in exchanging small amounts of business data between two applications set up for such exchanges. XML schemas for AEC include BACnet (Building Automation and Control networks) (BACnet 2010), a standard protocol for building mechanical controls; AEX (Automating Equipment Information Exchange) (AEX 2010) for identifying mechanical equipment; AECxml, an XML version of the IFC schema (IAI 2010a); and cityGML (City Geography Markup Language) (CityGML 2010), an exchange for representing buildings within a GIS (Geographical Information System) format for urban planning, emergency services, and infrastructure planning.

With the advent of the World Wide Web, several different alternative schema languages were developed. These took advantage of streaming of information packets that could be processed as they were received, in contrast to file transfers that require the complete transfer of data before they can be processed. While file-based data transport is still common, XML provides streaming data packaging that is attractive for many uses. With cell phones and other devices, other transport media, such as GSM (Groupe Spécial Mobile), GPRS

(General Packet Radio Service), and WAP (Wireless Application Protocol) can be expected to be applied to building data.

Given the schema and schema language dimensions, exchanges can be classified in one of the three main ways listed below:

**Direct links** use the Application Programming Interface (API) of one system to extract data from that application and write the data using the receiving application's API. Some may write a temporary file in the exchange between two independent applications, others may rely on real-time exchanges calling one application from the other. Some applications provide proprietary interfaces, such as ArchiCad's GDL, Revit's Open API, or Bentley's MDL. Direct links are implemented as programming level interfaces, typically relying on C++ or C# languages. The interfaces make some portion of the application's building model accessible for creation, export, modification, checking, or deletion and the other programming interface provides capabilities for import and adaptation for the receiving application's data. Many such interfaces exist, often within a company's own product family and sometimes through a business arrangement between two or more companies.

Software companies often prefer to provide direct link or proprietary exchanges to specific software; they can support them better. The interfaces can be tightly coupled with, for example, an analysis tool directly embedded in the design application. These interfaces allow capabilities not easily supported through current public exchanges. The functionality of exchanges that are supported is determined by the two companies (or divisions within the same company) that identify certain use cases, defining where it lies in the design-build lifecycle and the assumed purpose(s). Sometimes the use cases that motivated the exchange capabilities are documented, but often they are not and thus are difficult to evaluate. Public definitions of BIM standards for use cases, outlined in Section 3.3.5, are driving the recognition that all building model exchanges need to have a use case specification, if they are to be relied upon. Because direct exchanges have been developed, debugged, and maintained by the two companies involved, they are typically robust for the versions of the software for which they were designed, and the use case functionality intended. Many exchanges fail because the translators were developed with different use cases in mind. The interfaces are maintained as long as their business relationship holds.

**A proprietary exchange format** is a file or streaming interface developed by a commercial organization for interfacing with that company's application. The specification for the schema may be published or confidential.

A well-known proprietary exchange format in the AEC area is DXF (Data eXchange Format) defined by Autodesk. Other proprietary exchange formats include SAT (defined by Spatial Technology, the implementer of the ACIS geometric modeling software kernel), STL for stereo-lithography, and 3DS for 3D-Studio. Each of these has their own purpose, dealing with different kinds of geometry.

**The public product data model exchange formats** involve using an open and publicly managed schema and language, such as XML or text file. Some product models support both XML and text file exchange (IAI 2010a). IFC, CIS/2, and ISO 151296 are all example public domain interfaces that will be described in more detail shortly.

A summary of the most common exchange formats in the AEC area is listed in Table 3–1. Table 3–1 groups file exchange formats with regard to their main usage. These include 2D raster image formats for pixel-based images, 2D vector formats for line drawings, 3D surface and solid shape formats for 3D forms. Three-dimensional object-based formats are especially important for BIM uses and have been grouped according to their field of application. These include the ISO-STEP-based formats that include 3D-shape information along with connectivity relations and attributes, of which the IFC building data model is of highest importance. Also listed are various gaming formats, which support fixed geometry, lighting, textures along with actors, and dynamic, moving geometry, and GIS public exchange formats for 3D terrain, land uses, and infrastructure.

As the computer-aided design field has progressed from 2D to 3D and more complex shapes and assemblies, the number of data types represented has grown tremendously. An ordinal charting of this phenomenon is shown in Figure 3–3. While 3D geometry of assemblies is complex, the additions of properties, object types, and relations has led to a large increase in the types of information represented. It is not surprising, then, that the purpose of data exchange has taken on increasing attention and importance, listing it as the most important issue for advanced BIM users (McGraw-Hill 2009). As the richness of data about a building grows, the issues of data exchange shifts from accurate translation to filtering just the information needed, and the quality of the information (e.g., is the data an estimated or nominal shape or property or those of a specific product?).

A natural desire is to “mix and match” software tools to provide functionality beyond what can be offered by any single software platform. This is especially true when diverse organizations are collaborating on a project as a team. Gaining interoperability of different systems used by the team is much

**Table 3–1** Common Exchange Formats in AEC Applications**Image (Raster) Formats**

JPG, GIF, TIF, BMP, PNG, RAW, RLE

Raster formats vary in terms of compactness, number of possible colors per pixel, transparency, compression with or without data loss

**2D Vector Formats**

DXF, DWG, AI, CGM, EMF, IGS, WMF, DGN, PDF, ODF, SVG, SWF

Vector formats vary regarding compactness, line formatting, color, layering and types of curves supported; some are file-based and others use XML.

**3D Surface and Shape Formats**

3DS, WRL, STL, IGS, SAT, DXF, DWG, OBJ, DGN, U3D PDF(3D), PTS, DWF

3D surface and shape formats vary according to the types of surfaces and edges represented, whether they represent surfaces and/or solids, material properties of the shape (color, image bitmap, and texture map), or viewpoint information. Some have both ASCII and binary encodings. Some include lighting, camera, and other viewing controls; some are file formats and others XML.

**3D Object Exchange Formats**

STP, EXP, CIS/2, IFC

Product data model formats represent geometry according to the 2D or 3D types represented; they also carry object type data and relevant properties and relations between objects. They are the richest in information content.

AecXML, Obix, AEX, bcXML, AGCxml

XML schemas developed for the exchange of building data; they vary according to the information exchanged and the workflows supported.

V3D, X, U, GOF, FACT, COLLADA

A wide variety of game file formats vary according to the types of surfaces, whether they carry hierarchical structure, types of material properties, texture and bump map parameters, animation, and skinning.

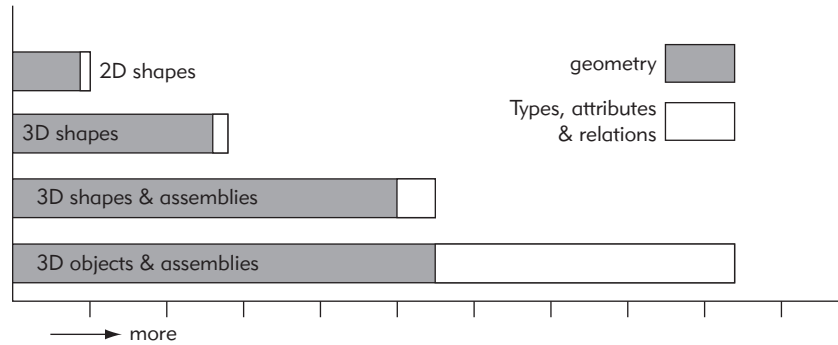
SHP, SHX, DBF, TIGER, JSON, GML

Geographical information system formats vary in terms of 2D or 3D, data links supported, file formats and XML.

easier than forcing all team firms onto a single platform. The public sector also wishes to avoid a proprietary solution that gives any one software platform a monopoly. IFC and CIS/2 (for steel) are public and internationally recognized standards. Thus they are likely to become the international standard for data exchange and integration within the building construction industries.

**FIGURE 3-3**

The increasing complexity of data for different types of exchange. Horizontal axis is the approximate number of object classes within the schema.



### 3.3 BACKGROUND OF PRODUCT DATA MODELS

With BIM, the number and range of AEC applications is expanding quickly for design, fabrication, construction, and building operations. The need for interoperability can only grow, not shrink. Until the mid-1980s, almost all data exchange in all design and engineering fields was based on various fixed schema file formats. DXF and IGES are well-known examples. These provided effective exchange formats for 2D and 3D geometry. However, object models of piping, mechanical, electrical, and other systems were being developed at this time. If data exchange was to deal with models of complex objects with their geometry, attributes, and relations, any fixed file exchange format quickly became very large and so complex as to be uninterpretable. These issues arose in both Europe and the United States at about the same time. After some back and forth, the International Standards Organization (ISO) in Geneva, Switzerland, initiated a Technical Committee, TC184, to initiate a subcommittee to develop a standard called STEP (STandard for the Exchange of Product Model Data), numbered ISO-10303, to address these issues. They developed a new approach and set of technologies to deal with advance data exchange issues.

One of the main products of ISO-STEP was the EXPRESS language, developed by Douglas Schenck and later contributed to by Peter Wilson (Schenck and Wilson 1994). The EXPRESS language has become the central mechanism to support the modeling of products across a broad range of industries: mechanical and electrical systems, process plants, shipbuilding, process plans, furniture, finite element models, and others, as well as buildings and bridges. It also includes a large number of libraries of features, geometry, classifications, measurements, and others to use as common foundations for product data models. Both metric and imperial measurements are supported. As a machine-readable language, it is excellent for computational use, but difficult

for human users; thus a graphical display version of the language was developed and is commonly used, called EXPRESS-G. All ISO-STEP information is in the public domain.

Surrounding the STEP standard is a collection of software companies providing toolkits for implementing and testing software based on EXPRESS. Text file and XML reading and writing is broadly supported, along with model viewers, navigators, and other implementation tools. A few BIM applications use IFC as their native data model; that is, they directly operate (read and write) on IFC data.

### 3.3.1 ISO-STEP in Building Construction

AEC organizations initially participated in ISO-STEP meetings and initiated some early STEP exchange models. Also, non-STEP organizations can use the STEP technologies to develop industry-based product data models and there are two major efforts of this type. Up to now, the following product models related to buildings have been developed, all based on the ISO-STEP technology and defined in the EXPRESS language:

- **AP 225**—Building Elements Using Explicit Shape Representation: the only completed building-oriented product data model developed and approved. It deals with the exchange of building geometry. AP 225 is used in Europe, mostly in Germany, as an alternative to DXF. Only a few CAD applications support it.
- **IFC**—Industry Foundation Classes: an industry-developed product data model for the design and full lifecycle of buildings, supported by buildingSMART. It has broad support by most software companies; it is weakened by varied nonconsistent implementations. More on IFC later.
- **CIS/2**—CimSteel Integration Standard, Version 2: is an industry-developed standard for structural steel design, analysis, and fabrication, supported by the American Institute of Steel Construction and the Construction Steel Institute in the United Kingdom. CIS/2 is widely used and deployed in the North American structural steel engineering and fabrication industry.
- **AP 241**—Generic Model for Life Cycle Support of AEC Facilities: addresses industrial facilities, and overlaps with IFC functionality; proposed in 2006 by the German National Committee; and is under review as a new AP. The Korean buildingSMART chapter is also involved. The purpose of AP 241 is to develop a product data model for factories and their components in a fully ISO-STEP-compatible format.

- **ISO 15926**—A STEP standard for *industrial automation systems and integration: Integration of life-cycle data for process plants including oil and gas production facilities*. It addresses the whole lifecycle, from planning and design to maintenance and operation. Because a process plant is continuously maintained, objects are naturally 4D. ISO 15926 evolved from an earlier European Community EPISTLE project and was strongly supported by Det Norske Veritas, known as DNV ([www.dnv.com/](http://www.dnv.com/)). It brought together various ISO STEP part models, for 2D plant schematics, for plant physical layout, and for plant process modeling. ISO 15926 was adopted by a consortium of firms under FIATECH, and was refined and adopted for North American use. The schema supports the concept of Facades, which is similar to model views. ISO 15926 relies on EXPRESS and other ISO-STEP formats.

ISO 15926 has seven parts:

*Part 1*—Introduction, information concerning engineering, construction, and operation of production facilities is created, used and modified by many different organizations throughout a facility's lifetime. The purpose of ISO 15926 is to facilitate integration of data to support the lifecycle activities and processes of production facilities.

*Part 2*—Data Model. a generic 4D model that can support all disciplines, supply chain company types, and lifecycle stages, regarding information about functional requirements, physical solutions, types of objects, and individual objects as well as activities.

*Part 3*—Geometry and Topology, defining, in OWL, the geometric and topology libraries of ISO-STEP.

*Parts 4, 5, 6*—Reference Data, the terms used within facilities for the process industry.

*Part 7*—Implementation methods for the integration of distributed systems, defining an implementation architecture that is based on the W3C Recommendations for the Semantic Web.

An important part of ISO 15926 is its large set of libraries, covering fluids, electrical, and mechanical components.

There are multiple building product data models with overlapping functionality, all using the EXPRESS language. They vary in the AEC information they represent and their intended use, but with overlaps. IFC can represent building geometry, as can AP 225 and ISO 15926. There is overlap between CIS/2 and IFC in the design of structural steel. ISO 15926 overlaps IFC in the



pipng and mechanical equipment areas. These largely separate efforts will need to be harmonized. Harmonization efforts are being discussed between 15926 with IFC, especially in the mechanical equipment area, but no steps have been undertaken (as of 2010).

### 3.3.2 buildingSMART and IFC

The IFC has a long history. In late 1994, Autodesk initiated an industry consortium to advise the company on the development of a set of C++ classes that could support integrated application development. Twelve U.S. companies joined the consortium. Initially defined as the Industry Alliance for Interoperability, the Alliance opened membership to all interested parties in September, 1995 and changed its name in 1997 to the International Alliance for Interoperability. The new Alliance was reconstituted as a nonprofit industry-led international organization, with the goal of publishing the Industry Foundation Class (IFC) as a neutral AEC product data model responding to the building lifecycle. It would be based on ISO-STEP technologies, but independent of its bureaucracy. In 2005, it was felt that the IAI name was too long and complex for people to understand. At a meeting in Norway of the IAI Executive Committee, IAI was renamed buildingSMART. The various chapters are now buildingSMART chapters. A good historical overview of the IFC is available on the IAI Web site: [www.iai-international.org/About/History.html](http://www.iai-international.org/About/History.html). As of 2009, buildingSMART has 13 chapters in 18 countries worldwide, with about 450 corporate members. It is truly an international effort.

All chapters may participate in Domain Committees, each of which addresses one area of the AEC. Currently, the Domains include:

- AR—Architecture
- BS—Building Services
- CM—Construction
  - CM1—Procurement Logistics
  - CM2—Temporary Construction
- CS—Codes and Standards
- ES—Cost Estimating
- PM—Project Management
- FM—Facility Management
- SI—Simulation
- ST—Structural Engineering
- XM—Cross Domain

By participating in a Domain Committee, members have input to the portion of the IFC that corresponds to their interests. Different national chapters are focusing on different domains.

The International Council Executive Committee is the overall lead organization of buildingSMART International. The North American buildingSMART chapter is administered by NIBS, the National Institute of Building Science, in Washington, D.C.

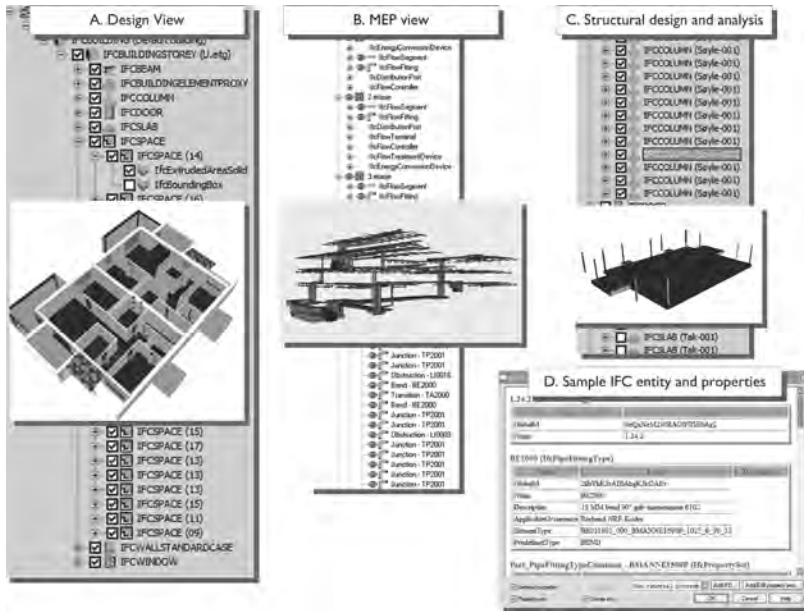
### 3.3.3 What Is the IFC?

The Industry Foundation Class (IFC) is a schema developed to define an extensible set of consistent data representations of building information for exchange between AEC software applications. It relies on the ISO-STEP EXPRESS language and concepts for its definition, with a few minor restrictions on the EXPRESS language. While most of the other ISO-STEP efforts focused on detailed software exchanges within specific engineering domains, it was thought that in the building industry this would lead to piecemeal results and a set of incompatible standards. Instead, IFC was designed as an extensible “framework model.” That is, its developers intended it to provide broad, general definitions of objects and data from which more detailed and task-specific models supporting particular exchanges could be defined. In this regard, the IFC has been designed to address all building information, over the whole building lifecycle, from feasibility and planning, through design (including analysis and simulation), construction, to occupancy and building operation (Khemplani 2004). Several of the case studies show different uses of IFC, particularly the Helsinki Music Hall and the Crusell Bridge (see Chapter 9). Because of its growing role in AEC interoperability, we describe it here in some detail.

A small example of this breadth is shown in Figure 3–4.

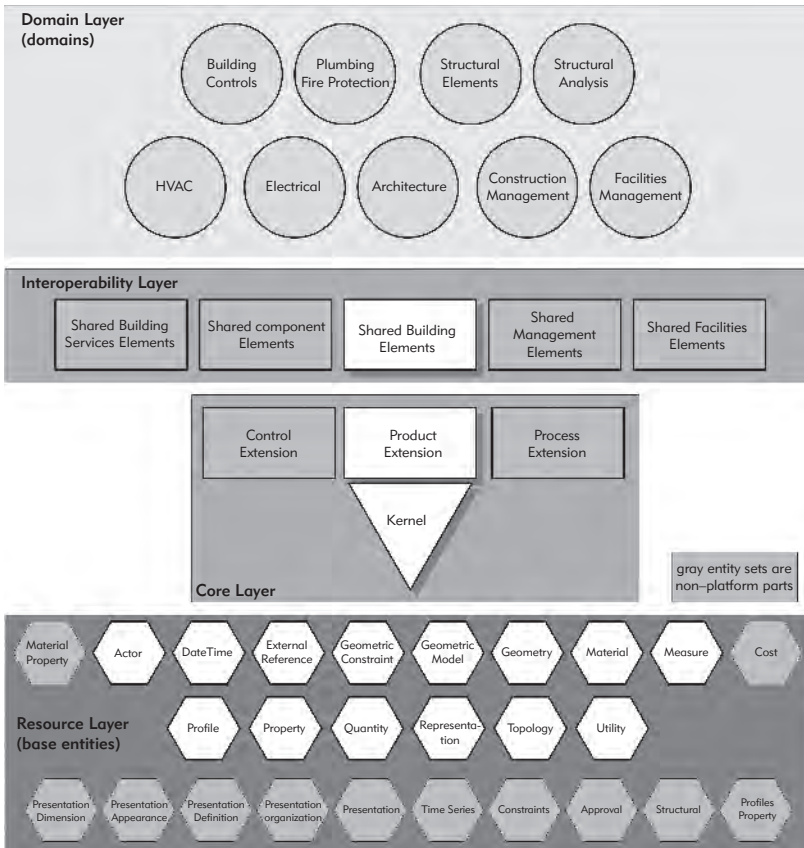
As of 2010, a new version of the IFC has been released, Version 2x4. This release of IFC has about 800 entities (data objects), 358 property sets, and 121 data types. While these numbers indicate the complexity of IFC, they also reflect the semantic richness of building information, addressing multiple different systems, reflecting the needs of different applications, ranging from energy analysis and cost estimation to material tracking and scheduling. Interfaces based on it are currently being implemented by the major BIM design tool and platform software companies, replacing the older 2x3 version. It is available for review at: [www.iai-tech.org/products/ifc\\_specification/ifc-releases/summary](http://www.iai-tech.org/products/ifc_specification/ifc-releases/summary).

The conceptual organization of IFC can be considered in several ways. A system architecture perspective is diagrammed in Figure 3–5. At the bottom are 26 sets of base EXPRESS definitions, defining the base reusable constructs, such as Geometry, Topology, Materials, Measurements, Actors, Roles, Presentations,



**FIGURE 3-4**  
IFCs consist of a library of object and property definitions that can be used to represent a building project and support use of that building information for a particular purpose.

The figure shows three examples of specific domain uses from a single IFC project: (A) An architectural view, (B) a mechanical system view, and (C) a structural view. Also shown are (D) a sample IFC object or entity and sample properties and attributes.



**FIGURE 3-5**  
The system architecture of IFC subschemas.

Each Resource and Core subschema has a structure of entities for defining models, specified at the Interoperability and Domain Layers.

Adapted from IAI International IFC/ifcXML online specifications for IFC2x Edition 4 at [www.iai-tech.org/products/ifc\\_specification/ifc-releases/ifc2x4-release](http://www.iai-tech.org/products/ifc_specification/ifc-releases/ifc2x4-release).

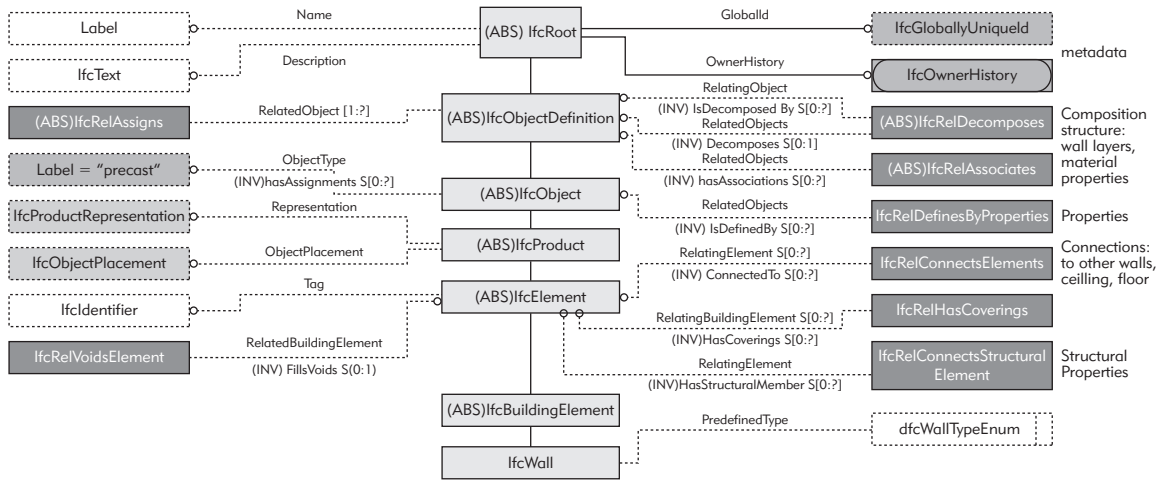


FIGURE 3-6 The IFC structure for defining a wall.

and Properties. These are generic for all types of products and are largely consistent with ISO-STEP shared library Resources, with minor extensions.

The base entities are then composed to define commonly used objects in AEC, termed Shared Objects in IFC. These include building elements, such as generic walls, floors, structural elements, building service elements, process elements, management elements, and generic features. Because IFC is defined as an extensible data model and is object-oriented, the base entities can be elaborated and specialized by subtyping<sup>1</sup> to make any number of subentities.

At the top level of the IFC data model are the domain-specific extensions. These deal with different specific entities needed for a particular use. Thus there are Structural Elements and Structural Analysis Extensions, Architectural, Electrical, HVAC, and Building Control Element Extensions.

Because of the IFC hierarchical object subtyping structure, the objects used in exchanges are nested within a deep subentity definition tree. All physical objects, process objects, actors, and other basic constructs are abstractly represented similarly, for example, a wall entity has a trace down the tree shown in Figure 3-6.

Each level of the tree in Figure 3-6, introduces different attributes and relations to the wall entity. *IfcRoot* assigns a Global ID and other information

<sup>1</sup>Subtyping provides for defining a new class of building object that “inherits” the properties of its “parent” class and adds new properties that make it distinct from its parent and any possible “sibling” classes. IFC superclasses, subclasses, and inheritance behavior conform to accepted principles of object-oriented modeling. For more detail, see Booch 1993.

for managing the object, such as who created it and when. *IfcObjectDefinition* places the wall into the aggregate building story assembly. This level also identifies the components of the wall, including windows, doors, and any other openings. The *IfcObject* level provides links to properties of the wall, based on its type (defined lower down in the tree). *IfcProduct* defines the location of the wall and its shape. *IfcElement* carries the relationship of this element with others, such as wall bounding relationships, and also the spaces that the wall separates. It also carries any openings within the wall and optionally their filling by doors or windows. If the wall is structural, a structural element representing the wall can be associated with it.

Walls are typed as one of the following: *Standard*: extruded vertically with a fixed width along its control line; *Polygonal*: extruded vertically but with varying cross section; *Shear*: walls not extruded vertically; *ElementWall*: walls composed of elements such as studs and sheathing; *PlumbingWall*: wall with embedded routing space; *Userdefined*: all other types; *Undefined*. Many of these attributes and relations are optional, allowing implementers to exclude some of the information from their export routines. It is possible that not all BIM design tools can create or represent all of the different wall types.

Properties are carried in optional P-sets. The *PSetWallCommon* provides fields to define: Identifier, AcousticRating, FireRating, Combustibility, SurfaceSpreadOfFlame, ThermalTransmittance, IsExterior, ExtendToStructure (to slab above), LoadBearing, Compartmentation (firewall). Other more detailed P-sets are also supported if needed. Openings, notches and reveals, and protruding elements, such as pilasters, are supported, along with walls clipped by irregular ceilings.

All IFC models provide a common general building spatial structure for the layout and accessing of building elements. It organizes all object information into the hierarchy of *Project* -> *Site* -> *Building* -> *BuildingStorey* -> *Space*. Each higher-level spatial structure is an aggregation of lower-level ones, plus any elements that span the lower-level classes. For example, stairs usually span all building storeys and thus are part of the Building Aggregation. Walls typically bound two or more spaces on one or multiple stories. They are typically part of the BuildingStorey, if structured within a single story and part of the Building Aggregation if they span multiple stories.

From this wall example, one gets a sense for how all building elements in IFC are defined. There are many types of assemblies, P-sets, and features that can support structural, mechanical, and other system elements. Analysis models, load data, and product performance parameters can also be represented in some areas.

### 3.3.4 IFC Coverage

While IFC is able to represent a wide range of building design, engineering, and production information, the range of possible information to be exchanged in the AEC industry is huge. The IFC coverage increases with every release and addresses limitations, in response to user and developer needs. Here we summarize the major coverage and limitations as of early 2010.

All application-defined objects, when translated to an IFC model, are composed of the relevant object type and associated geometry, relations, and properties. In addition to objects that make up a building, IFC also includes process objects for representing the activities used to construct a building, analysis geometry that is often abstracted from the building geometry, and analysis input and result properties.

**Geometry:** The IFC has means to represent a wide range of geometry, including extrusions, solids defined by a closed connected set of volume-enclosing faces (B-Reps), and shapes defined by a tree of shapes and Union-intersection operations (Feature Addition and Subtraction and/or Constructive Solid Geometry). By default, most shapes are exported as B-Reps. With release 2x4, surfaces may be those defined by extruded shapes (including those extruded along a curve) and Bezier and now Non-Uniform Rational B-spline (NURBS) surfaces. Parts of shapes may be distinguished as shape features. These cover almost all construction needs and most design needs. The IFC geometry was designed to support exchange of simple parametric models between systems, such as wall systems and other extruded shapes. However, not all of the needed information, especially rules and constraints, can be exchanged, resulting in some editing required to exchange editable parametric models. Few translators have made use of the parametric capabilities, however, and their power is just beginning to be explored. Most exchanges do not require this level of detail of object behavior.

**Relations:** Relations are typed and link one object with another. Care has been taken in the IFC data model to represent a rich set of relations between objects in some BIM design tools for translation into IFC. A subset and their uses are shown in Figure 3–6. There are many subclasses of *IfcRelations* covering almost any desired relation. This is a complex area of definition and relation structures are refined with each IFC release. Questions occasionally arise regarding their use.

**Properties:** IFC places emphasis on *property sets*, or P-sets. These are sets of properties that are used together to define material, a particular type of performance, and contextual properties, for example, wind, geological, or weather data. There are collected P-sets for many types of building objects, such as common roof, wall, window glazing, window, and beam reinforcement. In addition, many properties are associated with different material behaviors,

such as for thermal material, products of combustion, mechanical properties, fuels, concrete, reinforcing, and others.

Several properties are missing. Measurements lack tolerance properties; there is no explicit way to represent uncertainty. In such cases, options are available to define and depict user-defined property sets. These must be managed by user agreement, as they are not yet built into the specification.

Other properties can be considered classifications, selected from a set of enumerated value. Space names are not standardized, as needed for many types of analyses, such as energy or building codes. As a result, they usually require special editing. The function of diverse structural elements needed for analyses and fabrication are lacking in IFC but are well defined in CIS/2. These include restraints, buckling assumptions, weld types, and specifications. Similar functional limitations apply to mechanical systems.

**Metadata:** IFC designers have thought about the use of information over time and the metadata needed to manage information. IFC is strong in addressing information ownership, tracking of changes, controls, and approvals. IFC also has capabilities to define constraints and objectives for describing intent. However, we are not aware of these capabilities being used.

The IFC has well-developed object classes for buildings at the architectural level of detail. In general, it currently is less strong in representing the details needed for fabrication and manufacturing. It only partially addresses reinforcing in concrete, metal welds and their specification, concrete mix and finish definition, or fabrication details for window wall systems, for example. This level of detail may either be defined in more detailed IFC product schemas, or as separate ones, such as CIS/2.

These different descriptions are brought together to describe the information represented in some design application, or to be received by a building application from some other application or repository. The current limitations are in no way intrinsic, but reflect the priority needs of users up to now. If extensions are needed to deal with the limitations noted, these can be added through a regularly scheduled extension process.

### 3.3.5 IFC in Use-BIM Standards

As the AEC field has matured, it has become recognized that the issue of interoperability has moved from data exchange between two BIM applications to supporting the use cases defined by workflows. The major benefits of interoperability are not only to automate an exchange (although replicating the data in another application is certainly redundant activity), but the larger benefits that refine workflows, eliminate steps, and improve processes. The new phrase is to better “manage lean workflows.”

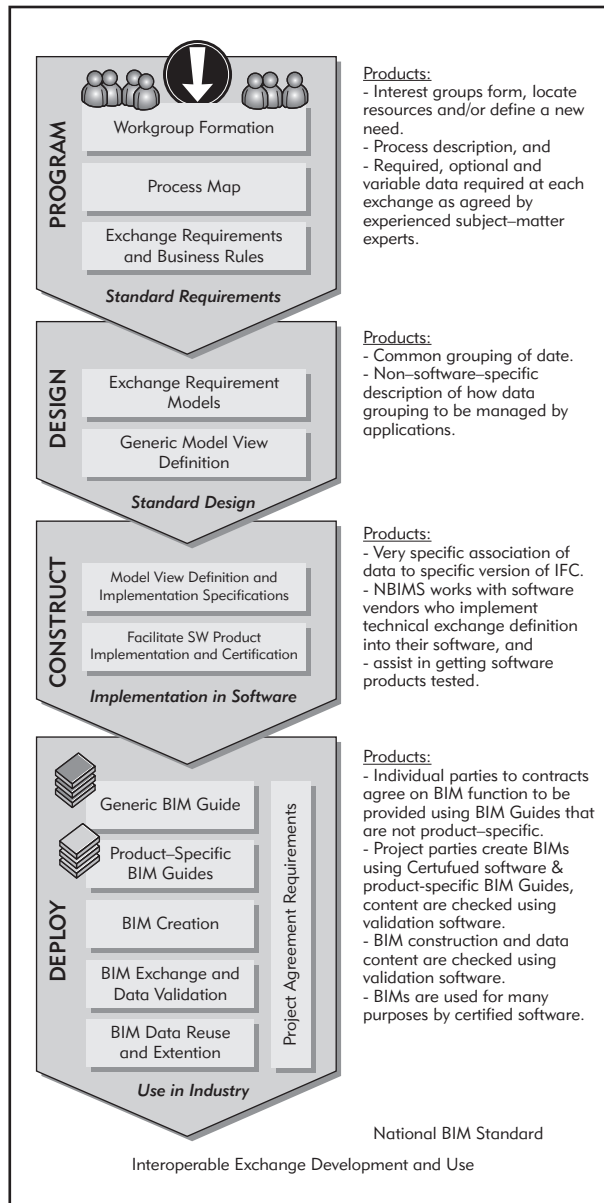
IFC, developed to respond to the different needs of designers, contractors, building product suppliers, fabricators, government officials, and others, is both rich and redundant. Its multiple types of geometry, many types of properties and relations, are necessary to identify the information needed for particular exchanges or tasks. Thus IFC is highly redundant. Task and workflow information requirements have become recognized as critical for successful exchanges. User interface buttons for “IFC export” and “IFC import” are completely insufficient. What is needed are task-related exchanges based on subsets of the IFC schema, for example, an “architect’s structural export for preliminary structural analysis” or a “curtain wall fabricator detail export to construction manager for fabrication-level coordination.” Such exchanges are called model views, drawing from the notion of a database view. This level of specificity involves identifying the exchanges to be supported and then specifying the IFC model view of the information that the exchange needs.

Model views are another level of specification, above the IFC schema. Realizing this added layer of specification in the United States has been taken on by the National Institute of Building Science (NIBS) and the U.S. buildingSMART organization. Similar organizations have taken up the charge in other buildingSMART chapters (IAI 2010). The U.S. effort led to the development of a report: U.S. National Building Information Modeling Standard, Version 1, Part 1, released in December 2007 (NIBS 2008). It lays out a process to be followed in developing model views. This is characterized in Figure 3–7.

### ***Why Are Model Views Important?***

Whether carried out for public or proprietary exchanges, Model View Definitions (MVD) identify what should be expected for an exchange to be effective. This helps the users at both ends; the exporter knows what is required—and also what is not required. The receiver knows what can be expected and acted upon. “Should the architect’s model of preliminary design of a precast concrete façade include the embedded window details?” “What kind of geometry is needed for exchanges when façade connections are defined by the structural or precast engineer?” Such questions are today worked out by trial and error. Most importantly, model views define for implementers what is to be implemented, so that both export and import are aligned, eliminating mismatches regarding assumptions. These are the immediate uses of MVDs. Today, the goal is to define effective IFC exchanges, to smooth and expedite workflows. When this happens, model views will take on expanded roles. There is both the need and opportunity to define the handover specifications for different phases of project delivery, for example from design to construction, and for construction to operation, such as defined by Construction Operations Building



**FIGURE 3-7**

This figure shows the four major steps for defining and implementing an NBIMS of Program, Design, Construct, and Deploy.

information exchange (COBie), see Section 3.4.3. These will evolve into finer-grain exchanges and become part of the definition of project scope. They are expected to be defined within contracts to specify milestone handovers. They will then need to be defined for direct exchange between applications as well and public data schema exchanges. The point is, MVDs respond to very important needs in building procurement, far beyond IFC interoperability.

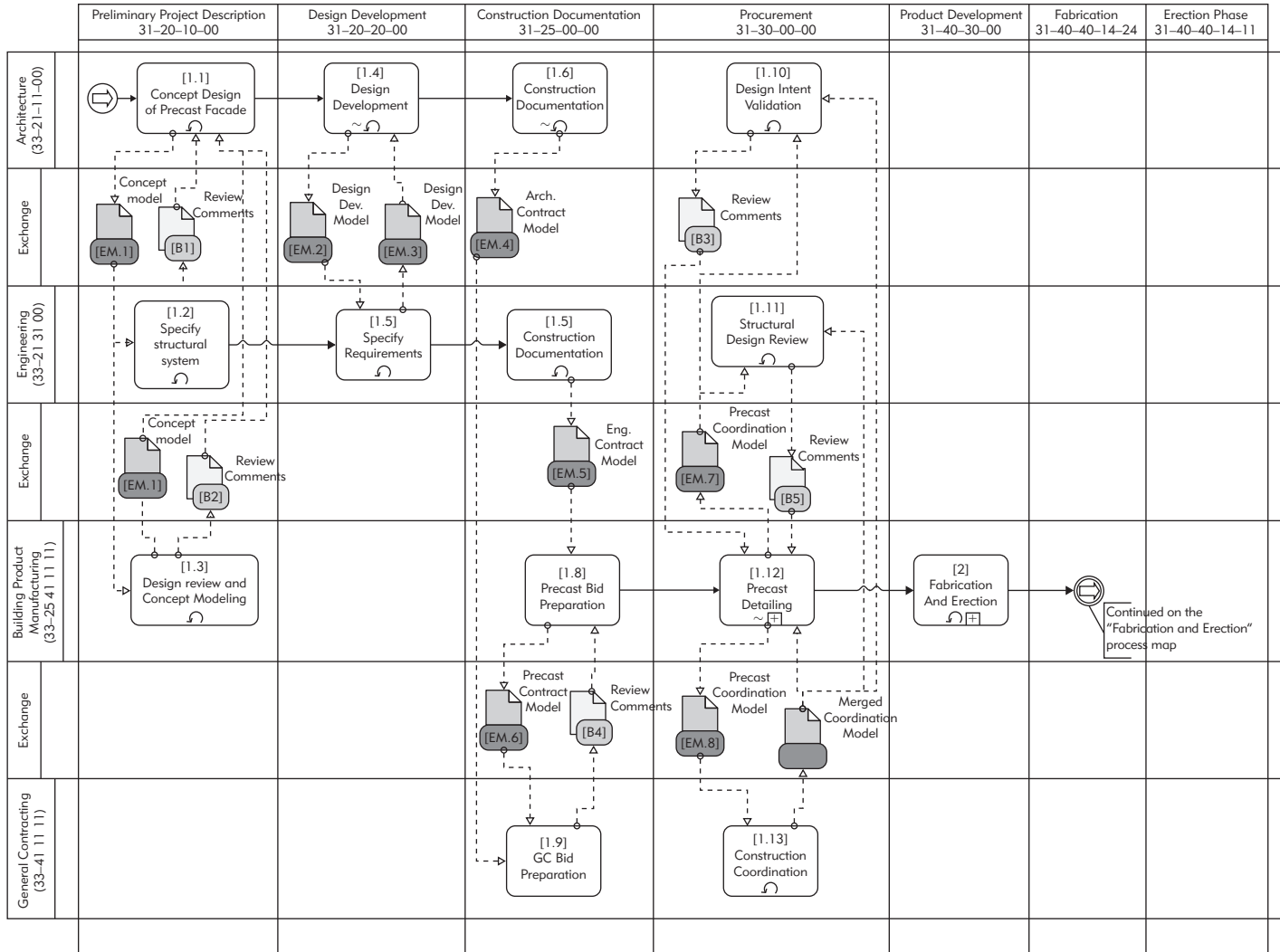
In North America, it was recognized that industry-led efforts to define workflows should be the driving force, as the industry stakeholders are who benefit from improving IT and getting software companies to support them. The *National BIM Standard* (NIBS 2008) was developed by buildingSMART America to identify the need and outline an approach to specifying and implementing MVDs. Below we provide an overview of the NBIMS process.

### ***Phase One: Program***

The initial step is to identify and form an industry-led group to define the needed exchanges according to model views. These groups are usually formed under umbrella organizations, such as the American Institute of Architects, the Association of General Contractors, American Society of Civil Engineers, the American Institute of Steel Construction, the Precast Concrete Institute, as well as others. This working group identifies a set of exchanges they wish to see implemented, then specify them functionally in sufficient detail for them to be translated into IFC constructs that can be implemented.

The buildingSMART organization has adopted a well-known process modeling language, BPMN, used in electronic e-business planning and implementation, for modeling exchanges. Business Process Modeling Notation (BPMN, [www.bpmn.org](http://www.bpmn.org)) provides clear ways to describe activities and the information flows between activities in what is called a Process Map. A process map showing a typical set of information exchanges is shown in Figure 3–8. It defines a set of tasks and exchanges specified for handling an architectural precast concrete project, using IPD types of collaboration (Eastman et al. 2009). The following outlines some guidelines for reading a BPMN process map.

There are many BPMN diagramming tools; the one used in Figure 3–8 was made using Visio, which has a plug-in for BPMN shapes at the BPMN Web site, at [www.bpmn.org/documents.htm](http://www.bpmn.org/documents.htm). Alternatives to Visio are also listed there. The horizontal rows and the vertical columns in a BPMN process map are called “swim lanes.” The rows identify the “Disciplines” involved in the exchanges. In between the Discipline rows are “Exchange” rows. These organize and group exchanges between Disciplines. The vertical columns identify project Phases. Within the cells created by the swim lanes, white rectangles with rounded corners signify Activities. The appropriate Discipline’s row and project Phase column identifies the context of the exchange. Each Activity has an identifier, linked to a more extensive description. Within an Activity box, there may be several symbols across the bottom; a directed arc designates the Activity may be iterated. A plus box indicates the Activity is a high-level description made up of a set of Activities described separately and



**FIGURE 3-8** A process map of exchanges between architect, structural engineer, and precast fabricator during the design stages.

(Eastman et al. 2009a)

hierarchically—BPMN provides hyperlinks between high-level and detail Activities. (The full graphic syntax of BPMN is available from [www.bpmn.org/](http://www.bpmn.org/)).

The corner folded blocks in the Exchange lanes designate Information Exchanges. The gray information exchanges are building model exchanges, while the white ones are reports represented as text or voice messages. These also have IDs for cross-referencing. It is a gray exchange that we are primarily interested in and they are called Exchange Models (EMs).

The process map shows several different types of exchanges. In the first column, exchanges between architect, engineering, and building product manufacturing (here a precast fabricator) are shown. In both cases, the architect releases a BIM model for review by the engineer and the precast fabricator. The return information involves comments and suggestions, based on the model reviewed. These are clearly one-way exchanges.

During design development, we see another exchange between the architect and engineer. Here the exchange passes a building model in both directions. The structural engineer may propose changes to the received building model to indicate how the architectural precast may be carried by the structure. This is a two-way or iterative exchange.

For each of the EMs, the working group provides detail specifications of the content of each exchange. This functional specification must determine the type of entities, their geometry, attributes, level of detail, material or processes that are needed for passing from one application to another (Aram et al. 2010). The final outcome of the Program Phase is a report, called an Information Delivery Manual (IDM) (Eastman et al. 2010a), that identifies a set of exchanges and specifies their content from the user's perspective. The specification is fully reviewed and approved by the domain committee.

### ***Phase Two: Design***

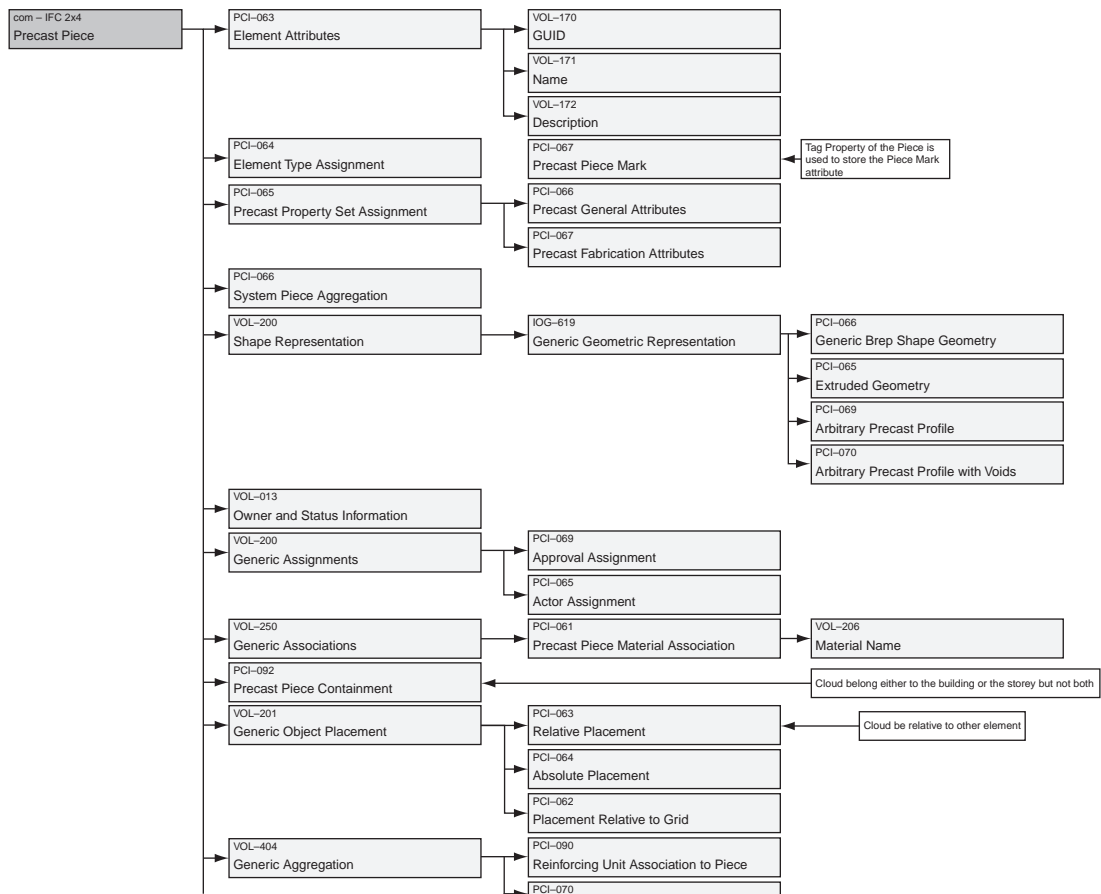
The Exchange Requirements identified in the IDM are next structured into a set of information modules that are the units of the exchange, defined to be mapped to the implementation schema—IFC most commonly, or CIS/2 or an XML schema. The work is carried out by IT specialists who collaborated with the domain experts in Phase One.

When early groups began developing Model Views, it was found that they included many repeated model constructs, for geometry, links between parts and assemblies, between physical pieces and analytic representation of those pieces, for example. Repeated specification, implementation, and testing of these constructs is a waste of time; they should be defined once and implemented and tested once, and reused. The constructs identified in this way were called Concepts. Concepts are a fundamental part of the Model View

&lt; COVER PAGE

## IFC Model View Definition Diagram : Precast Piece IFC 2x4

VIEW ID	VIEW NAME	APPLICATION NAME	APP VERSION	EXCHANGE TYPE	DIAGRAM STATUS	DIAGRAM VERSION	DIAGRAM DATE	DIAGRAM AUTHORS
PCI-001	Precast Concrete	Generic	Generic	Generic	Draft	1	9-Sep-09	Rafael Sacks, Chuck Eastman



**FIGURE 3-9** A high-level Concept that defines a Precast Piece, showing its breakdown into more detailed Concepts and eventually to Leaf Concepts, which carry the IFC bindings.

(Eastman et al. 2010b)

methodology. They are a hierarchical structure of mappings from the user-defined Exchange Models, decomposed into modular units of implementation binding. An example is shown in Figure 3-9.

The Concept definitions defined for a wide variety of MVDs are shared through an open Web site, IFC Solutions Factory, at [www.blis-project.org/IAI-MVD/](http://www.blis-project.org/IAI-MVD/). They are available for public review and, most importantly, for reuse. These Concepts, if well-structured, are a potentially important modularization of small unit structures that can be reused in many MVDs (Eastman et al. 2010a).

A well-structured set of templates have been developed for documenting the Concepts and their aggregation into higher-level Concepts, then into a Model View for a single exchange. When the templates are filled out, the resulting online documentation serves as the specification for the Model View Definition, which is the second major document (Eastman et al. 2010b). The MVD is the fulfillment of the requirements defined in the IDM, and should be validated by checking its Concepts against the IDM. Currently, this validation is done manually. The Design Phase specifies the implementation bindings and how all properties are to be handled, providing the software implementation specification of a Model View Definition.

### ***Phase Three: Construct***

The third phase addresses the implementation of the Model Views by software companies (who should be engaged throughout the previous phases). Implementation is of the MVD specification developed in Phase Two. It is augmented by small IFC test files which are available to test translator capabilities. It also needs to be augmented by small, easily implemented designs—in drawing or 3D model form—that can be built within a modeling tool being validated, so that can then be exported. The exported file is assessed to determine if the modeling tool can export information according to the MVD specification. These tests, for both import and export, need to cover all the individual variations that are included in the IDM, and specified in the MVD.

Testing of implementations is undertaken in two phases and is generally called Model View Validation. The initial tests are based on the implementation Concepts defined in the MVD and are called Unit Tests. These are tested for both import and export, for all the varied conditions that the MVD is supposed to support. Once the Unit Tests are successfully completed, larger integrated testing is required. Careful methods of both unit testing and full exchange model testing are required to be confident in the capability of an Exchange Model between two software applications. Certification is the formal designation that an implementation of a Model View Definition has been rigorously tested and can be relied upon by users.

Recently, two initiatives for Model View Validation and Certification has been implemented as Web sites by the buildingSMART International Implementation Support Group (ISG). One is the Global Testing Documentation Server and is hosted by the Institute for Advanced Building Informatics (IABI) at Technical University, Munich (<http://portal.bau.hm.edu/IABI/leistungsprofil/testplattform>). It supports both import and export testing of Concepts and complete Model Views. It is expected to serve as a validation and certification test site for developers, and also be accessible to users. The

other is part of IFC Solutions Factory ([www.blis-project.org/IAI-MVD/](http://www.blis-project.org/IAI-MVD/)). It provides testing primarily of export exchanges and has rigorous testing of export translators.

#### ***Phase Four: Deploy***

The last phase involves deployment and field use of the MVD. This should be supported by Guidelines that document the model views and how the user should correctly model its components within a particular BIM tool. This lets the users of applications know what they need to do to prepare models that carry the information required in the exchange. This phase also includes the development of project test models that can be used for real-life testing. Certification of implementations is also called for, although the organizational issue of who oversees certification is unanswered at this time.

When these specific workflow-based translators are implemented, they will be explicitly incorporated into translators, based on P-21 files, XML, or database queries. These Views, when certified, will add significantly to the robustness of IFC exchanges and eliminate the need for pretesting and trial exchanges, as are required today.

The IFC Solutions Factory identifies 23 efforts to define MVDs, as of April, 2010. These include structural analysis exchange, transfer of as-built data to facility operations site planning, code compliance, quantity takeoffs, and others. The development and testing of Model View Definitions has been a large undertaking and we are only beginning to see the fruits of these endeavors. An important benefit of the IFC Solutions Factory is that new MVDs can increasingly reuse the Concepts of previous MVDs for their definition. Also, the modularization of MVD implementations could also eventually result in easy implementation as well. We expect there will be several dozen MVDs from which to choose within the selection window of BIM platform software in the future.

#### ***Summary***

At this point in time (mid-2010) there are significant efforts to apply the IFC in various parts of the world:

- Multiple agencies around the world have initiated efforts to develop automatic building code checking capabilities (Eastman et al. 2009a).
- The Norwegian government agency for construction, Statsbygg, and its construction industry are working together to initiate changes in their construction industry, including building control (automatic code checking), planning (e-submission of building plans), and integration throughout all phases: design, procure, build, and facility management.

Their initiative, also called BuildingSmart®, is expected to produce a significant impact on the efficiency, productivity, and quality of the construction industry. See “Industry Initiatives and Norwegian Solution” at [www.iai-international.org/](http://www.iai-international.org/).

- The General Services Administration of the U.S. government has undertaken a series of BIM demonstration projects, addressing various applications, many relying on IFC-based exchanges. These are described on the same IAI Web site mentioned above, under Industry Solutions, GSA Pilots. Based on these demonstrations, all GSA building projects starting in 2007 and later are to utilize BIM design tools and use of an exported model in IFC format to support checking of the final concept design against the specific project’s programmatic spatial requirements. These activities have led to the draft development of GSA BIM guidelines to be followed for all new GSA projects (GSA 2006a). GSA’s work is in collaboration with Statsbygg and Senatti, the Finnish GSA equivalent.

Additional parallel initiatives are being undertaken in Finland, Denmark, Germany, Korea, Japan, China, and other countries.

### **3.3.6 Implications of IFC Interoperability**

It appears that MVDs will provide a new level of exchange capabilities and incrementally resolve the interoperability problem. However, it is useful to recognize that MVDs are based on specific processes and if exchanges are robust and reliable, further advantage will be taken of these capabilities. Some can be automated. That is, instead of one application being directed (by a user) to export a file and another user and application importing the file, we can begin to explore applications that will automatically export model views and import them into another application, for different automated uses (cost estimation, rule checking, analysis, or spatial conflict testing), with the results being sent back. MVDs open the door to new levels of design enhancement that have yet to be explored.

MVDs also have wider uses. As the IFC data model becomes adopted by various government organizations for code checking and design review (currently being undertaken by GSA, Singapore and Wisconsin), it will have an increasingly strong impact on aspects of architectural and contractor practice. This impact simultaneously affects users and BIM design tool developers. The completion of a set of contract drawings in traditional practice imposes one level of rigor and discipline in the final generation of those drawings. This discipline and rigor will increase significantly in the creation and definition of building models that carry adequate data for code checking, design review,



and various types of analysis. The only way that such models will be reliably defined is to specify their requirements as model views.

Firms will have to carefully prepare and run their models through a pre-check application to make sure projects are modeled appropriately for the intended uses. This includes the representation of objects in the needed object classes or families (walls as walls, stairways as stairs) that carry the needed property sets. The authoring tools will have to improve their capability to allow custom objects to have the needed class structures. Programs already exist to do pre-checking for the GSA BIM uses (Solibri 2010). For example, a check can be run that space objects fully cover slabs inside walls and that all are tagged with needed classifications with properties defining their name and intended function.

The IFC is the only public, nonproprietary and well-developed data model for buildings and architecture existing today. Extensions are continuously being developed in a range of areas, including geographic elements, precast concrete and piping, ducts and electrical elements. It is a de facto standard worldwide and is being formally adopted by different governments and agencies in various parts of the world. It is being picked up and used for a growing number of uses, in both the public and private sectors. Its real test as an interoperability standard will occur when MVDs are implemented and tested.

---

## 3.4 OTHER EFFORTS SUPPORTING STANDARDIZATION

IFC is only one piece of a huge puzzle regarding conventions and standards in the construction industry. While IFC addresses the data structures dealing with geometry, relations, and attributes, how will the attributes be named and used? How will the Chinese and other people who don't use the Roman alphabet work with those who do? Interoperability is a wider issue than is addressed by IFC or any current XML schema. While industries have grown up dealing with the classification and testing of construction materials, the same now needs to be done regarding other types of construction information. Here we provide a quick reference and overview of other BIM-related standards efforts.

### 3.4.1 International Framework for Dictionaries

The European Community early saw an issue in the naming of properties and object classes. A Door is *Porte* in French, *Tür* in German, and 门 in Mandarin. Each of its properties also has different names. Objects specified in IFC may have names and attributes in different languages and their meanings need to be properly interpreted. Fortunately, IFC deals well with measures in different units (SI and Imperial). Moreover, one may encounter different

standards, such as CIS/2 and IFC that have overlapping objects and properties that are treated differently, even though they are in the same language. The International Framework for Dictionaries was formed to address these issues and can be found at [www.ifd-library.org/index.php/Main\\_Page](http://www.ifd-library.org/index.php/Main_Page). It is developing mappings of terms between different languages, for eventual wide use in building models and interfaces. Another important effort being undertaken by IFD is the development of standards for building product specifications, particularly specification data, so these can be used in different applications, such as energy analysis, carbon footprint, and cost estimation.

IFD is being undertaken by the Construction Specifications Institute (CSI) in the United States, Construction Specifications Canada, buildingSMART in Norway, and the STABU Foundation in the Netherlands.

### 3.4.2 OmniClass

A related activity is the review and replacement of existing building-related classification systems, for their use in BIM. Both Masterformat<sup>®</sup> and Uniformat<sup>®</sup> are building element and assembly classification schemes used for specifications and cost estimation in the United States, and are overseen by the Construction Specification Institute. Both Masterformat and Uniformat are outline document structures that are excellent for aggregating information from project drawings, but do not always map well to the individual objects within a building model (although they can be mapped). Their limitations are described in Section 5.3.3.3. As a result, Europeans and Americans have embarked on a new set of outline-structured classification tables, called Omniclass<sup>™</sup>. Omniclass<sup>™</sup> has been developed by the International Organization for Standardization (ISO) and the International Construction Information Society (ICIS) subcommittees and workgroups from the early-1990s to the present. Currently it consists of 15 tables.

Table 11	Construction Entities by Function	Table 32	Services
Table 12	Construction Entities by Form	Table 33	Disciplines
Table 13	Spaces by Function	Table 34	Organizational Roles
Table 14	Space by Form	Table 35	Tools
Table 21	Elements	Table 36	Information
Table 22	Work Results	Table 41	Materials
Table 23	Products	Table 49	Properties
Table 31	Project Phases		

These tables of classification terms are being defined and structured by volunteer industries members. They are evolving quickly for adoption and use in BIM tools and methods.

### 3.4.3 COBie

Construction Operations Building information exchange (COBie) addresses the handover of information between the construction team and the owner. It deals with operations and maintenance (O&M), as well as more general facility management information. Traditionally, O&M information is provided in an ad hoc structure at the end of construction. COBie outlines a standard method for collecting the needed information throughout the design and construction process, as part of the deliverable package to the owner during commissioning and handover. It collects data from designers, as they define the design, and then by contractors as the building is constructed. It categorizes and structures the information in a practical and easy-to-implement manner.

Specific COBie objectives are (East, 2007):

- Provide a simple format for real-time information exchange for existing design and construction contract deliverables
- Clearly identify requirements and responsibilities for business processes
- Provide a framework to store information for later exchange/retrieval
- Add no cost to operations and maintenance
- Permit direct import to owner's maintenance management system

COBie specifies deliverables throughout all stages of design and construction, with specific deliverables in each of the phases below:

- Architectural Programming Phase
- Architectural Design Phase
- Coordinated Design Phase
- Construction Documents Phase
- Construction Mobilization Phase
- Construction 60 Percent Complete Phase
- Beneficial Occupancy Phase
- Fiscal Completion
- Corrective Maintenance

COBie was updated at the beginning of 2010 and is now called COBie2. It has formats for human as well as machine readability. The human readable format for COBie2 information is a conventional spreadsheet, provided in Microsoft Excel Spreadsheet format, on the WBDG Web site: ([www.wbdg.org/resources/cobie.php](http://www.wbdg.org/resources/cobie.php)). COBie2 also has been implemented for exchange of facility management data using the buildingSMART Industry Foundation Class (IFC) open standard (or its ifcXML equivalent). Translators between

**Table 3–2** COBie2 Data Sections

<b>Object Type</b>	<b>Definitions</b>
Meta Data	Exchange file
Project	Attributes, Units, Decomposition
Site	Attributes, Address, Classification, Base Quantities, Properties
Building	Attributes, Address, Classification, Base Quantities, Properties
Storey	Attributes, Base Quantities, classification, Properties
Spatial container	Attributes, Classification, Quantities, Properties, space boundaries,
Space Boundary	Doors, Windows, Bounding space
Covering	Attributes, Type, Covering material, Classification, Base Quantities
Window	Attributes, Type, Classification, Material, Base Quantities, Properties
Door	Attributes, Type, Classification, Material, Base Quantities, Properties
Furnishing	Attributes, Type, Material, Classification, Properties,
MEP elements	Attributes, Type, Material ,Classification, Properties
Proxy furniture, fixture, equipment	Attributes, Type, Material, Classification, Properties
Zone	Attributes, Classification, Properties, Spatial assignment
System	Attributes, Classification, Properties, Component Assignment, System Service Buildings

NOTE: Attribute, Type, Classification attribute types vary by object type.

IFC-Express and ifcXML to and from the COBie2 spreadsheet are available, free of charge, without technical support at ([www.buildingsmartalliance.org/index.php/projects/ifccobie](http://www.buildingsmartalliance.org/index.php/projects/ifccobie)).

COBie addresses the normal submittals required for handover at the end of a construction project, but puts them in a structured form, amenable to computer-based management. It includes the sections outlined in Table 3–2.

COBie2 has been developed to support the initial data entry into a Computerized Maintenance and Management System (CMMS); MAXIMO, TOCMO, Onuma, and Archibus support COBie2 as well as several European FM and design applications. It has been adopted as a required deliverable by VA hospitals, the U.S. Army Corps of Engineers, NASA, as well as several university systems. It is also being adopted by Statsbygg and Senatti, the respective Norwegian and Finnish government property acquisition and management organizations.

#### 3.4.4 XML-Based Schemas

Extensible Markup Language (XML) provides alternative schema languages and transport mechanisms, especially suited for Web use. In the same way that

## XML Schemas in AEC Areas

**OpenGIS®**, the Geographic Objects (GO) Implementation Specification has been developed by the OGC (Open Geospatial Consortium). It defines an open set of common, language-independent abstractions for describing, managing, rendering, and manipulating geometric and geographic objects within an application programming environment (OGC 2007).

**gbXML (Green Building XML)** is a schema developed to transfer information needed for preliminary energy analysis of building envelopes, zones, and mechanical equipment simulation (gbXML n.d.). Multiple platforms provide an interface.

**ifcXML** is a subset of the IFC schema mapped to XML, supported by IAI. It also relies on XML Schema, XSD, derived from the IFC EXPRESS release schema for its mapping. The language binding, for instance, the method of how to translate the IFC EXPRESS model into the ifcXML XSD model follows the international standard ISO 10303-28ed2 "XML representation of EXPRESS schemas and data." The ISO/CD 10303-28ed2 version of 05-04-2004 is used for the language binding.

**aecXML** is administered by FIATECH, a major construction industry consortium supporting AEC research, and the IAI. It initially developed an integration framework that attempted to harmonize ifcXML and aecXML, as an umbrella schema, that could support multiple subschemas. It relied on XML business technology developed by the United Nations Centre for Trade Facilitation and Electronic Business. The integration schema is called Common Object Schema (COS) that consists of level XML structures of names, addresses, amounts, and other base information units. aecXML was initiated to represent resources such as contract and project documents [Request for Proposal (RFP), Request for Quotation (RFQ), Request for Information (RFI), specifications, addenda, change orders, contracts, purchase orders], attributes, materials and parts, products, equipment; meta data such as organizations, professionals, participants; or activities such as proposals, projects, design, estimating, scheduling, and construction. It carries descriptions and specifications of buildings and their components, but does not geometrically or analytically model them. Bentley was an early implementer of aecXML. Recent activity is unknown (FIATECH 2007).

**agcXML** The Associated General Contractors (AGC) developed agcXML in 2007, a schema that supports construction business processes, based on the COS master schema of the aecXML effort. Its schemas include the exchange of information commonly included in the following document types:

- Request for Information
- Request for Pricing/Proposals
- Owner/Contractor Agreements

*(Continued)*

- Schedule of Values
- Change Order
- Application for Payment
- Supplemental Instructions
- Change Directive
- Bid, Payment, Performance, and Warranty Bonds
- Submittals

agcXML is free and can be downloaded from: [http://iweb.agc.org/iweb/Purchase/ProductDetail.aspx?Product\\_code=AGCXML](http://iweb.agc.org/iweb/Purchase/ProductDetail.aspx?Product_code=AGCXML). It has been implemented by a few companies, including VICO and Newforma.

**BIM Collaboration Format (BCF)** is an XML format for person-to-person to go with other forms of exchange. It is called an Information Takeoff format. During design reviews, various action items are identified. These are then acted upon by the various members of the project team. But how should these action items be transmitted? The answer comes from clash detection tools that identify a clash in 3D coordinates, associates an offset camera position to display the condition, then appends the action item to be taken, as identified by the parties involved. Originally this capability was limited to the clash detection application, such as Navisworks. However, transmitted in XML, the action item can be imported into any BIM platform and displayed for the user to act on. The use can be much wider than clash detection; it can be used for any type of review, whether automated [such as generated by Solibri Model Checker (Solibri 2010)] or carried out manually through an in-person meeting or Web conference. The benefit of BCF is that it directly loads and runs in the BIM design platform that generated the component of interest. BCF was proposed and defined by Tekla and Solibri, and has received commitments for support from Autodesk, DDS, Eurostep, Gehry Technologies, Kymdata, MAP, Prozman, and QuickPen International.

**CityGML** is a common information model for the representation of 3D urban objects. It defines classes and relations for relevant topographic objects in cities and regional models with respect to their geometrical, topological, semantic, and appearance properties. Included are generalization hierarchies between thematic classes, aggregations, relations between objects, and spatial properties. This thematic information goes beyond graphic exchange formats and supports virtual 3D city models for sophisticated analysis tasks in different application domains like simulation, urban data mining, facility management, and thematic inquiries. The underlying model differentiates five levels of detail (LOD). CityGML files can (but don't have to) contain multiple representations for each object in different LOD simultaneously. For more information, see [www.citygml.org/1523/](http://www.citygml.org/1523/).

some exchange formats are strictly file-oriented, some of the new exchange formats are only XML-based. XML is an extension to HTML, the language used to send information over the Web. HTML has a fixed set of tags (a tag tells what kind of data follows and is a primitive schema) that define presentation formats, different kinds of media, and other types of fixed format Web data. XML expands upon HTML by providing user-defined tags to specify an intended meaning for data transmitted. XML has become very popular for exchange of information between Web applications, for example, to support e-commerce transactions or collect data.

There are multiple methods for defining custom tags, including Document Type Declarations (DTDs) that are developed for mathematical formulas, vector graphics, and business processes, among many others. There are multiple ways to define XML schemas, including XML Schema ([www.w3.org/XML/Schema](http://www.w3.org/XML/Schema)), RDF (Resource Description Framework) ([www.w3.org/RDF/](http://www.w3.org/RDF/)), and OWL Web Ontology Language ([www.w3.org/TR/2004/REC-owl-features-20040210/](http://www.w3.org/TR/2004/REC-owl-features-20040210/)). These are shown in Figure 3-2. Research is proceeding to develop even more powerful tools around XML and ever more powerful schemas, based on precise semantic definitions called *ontologies*. Practical results for these more advanced approaches have thus far been limited.

Using current readily available schema definition languages, some effective XML schemas and processing methods have been developed in AEC areas. Five of them are described in the previous box.

Each of these different XML schemas defines its own entities, attributes and relations, and rules. They work well to support work among a group of collaborating firms that implement a schema and develop applications around it. However, each of the XML schemas is different and incompatible. ifcXML provides a global mapping to the IFC building data model, for cross-referencing. Efforts are underway to harmonize the OpenGIS schema with IFC. Translators do exist for mapping IFC models to CityGML. XML formatting takes more space than, say, IFC clear text files (between 2 and 6 times more space). However, it can be processed significantly faster than a text file and thus works more effectively than file exchanges in many cases. The longer-term issue is to harmonize the other XML schemas with equivalence mappings between them and with data model representations. The analogy is when the railroads in the United States all rapidly built tracks over the country, each with their own gage; they worked fine within their own community, but could not link up.

Two important XML formats for publishing building model data are DWF and 3D PDF. These provide lightweight mappings of building models for limited uses. They are reviewed in Chapter 2.

### 3.5 THE EVOLUTION FROM FILE-BASED EXCHANGE TO BUILDING MODEL REPOSITORIES

This chapter reviews the technology already developed or being developed to support the reuse of information created in one application in other applications. But a basic point made in the introduction is that buildings require multiple models for their full design, engineering, and construction. We now return to that point to examine its implications.

Production use of IFC or XML file exchanges and other XML-based e-business exchanges has begun with application-to-application exchanges. Typically, one person in each department or consulting team is responsible for managing versions within a project; when the architect or engineer releases an update to the design, it is passed to the consultant organizations for their reconciliation and model synchronization. As projects grow, and project file structures get more complex, this style of coordination becomes increasingly complex. Project management at each firm, which is the historical way of doing it, is not effective when exchanges need to be processed rapidly. This management task can explode if the management of files is replaced with the management of objects.

The technology associated with the resolution of these types of data management issues is a *building model repository*. A building model repository (or BIM repository) is a server or database system that brings together and facilitates management and coordination of all project-related data. It is an adaptation and expansion of existing project data management (PDM) systems and Web-based project management systems. PDM systems have traditionally managed a project as a set of files and carry CAD and analysis package project files. BIM repositories are distinguished by providing object-based management capabilities, allowing query, transfer, updating, and management of model data partitioned and grouped in a wide range of ways to support a potentially heterogeneous set of applications. The evolutionary change in the AEC field from managing files to the managing of information objects has only begun to take place.

BIM repository technologies are a new technology that has different requirements than the equivalent systems developed for manufacturing. Their functional requirements are only now being sorted out. We provide an overview of their desired functionality, as now understood. We then survey the major current products at the end of this section.

#### 3.5.1 Project Transactions and Synchronization

An important concept in databases is the definition of *transaction*. Transactions are what protect a database and also in-memory applications from



## Base Requirements for a BIM Repository

The base requirements for a BIM repository are fairly straightforward. Some are common to most database management systems. Others are basic needs articulated within the AEC industries and can be summarized as follows:

- *User access control* provides access and read/write/create capability for different levels of model granularity. Granularity of model access is important, since it identifies how much model data must be impounded for a user to revise it.
- *Represent users associated with a project*, so their involvement, access, and actions can be tracked and coordinated with workflows.
- *Read, store, and write* both all-native data models of platforms and also the derived data models used by other various BIM tools.
- *Read, store, and write open standard model data models* for some interoperability workflows and for project management.
- *Manage object instances* and read, write, and delete them based on update transaction protocols.
- *Support product libraries* for incorporating product entities into BIM models during design or fabrication detailing.
- *Support storing product specifications* and other product maintenance and service information, for linking to as-built models for owner handover.
- *Store e-business data*, for costs, suppliers, orders shipment lists, and invoices for linking into applications.
- *Provide model exchange capabilities for remote users*, for example, Web access, FTP file exchange, PDF, and XML.
- *Manage unstructured forms of communication*: email, phone records, notes from meetings, schedules, photographs, faxes, and videos.

These provide basic content capabilities of a BIM server. However, these capabilities do not address how complex object models and all their ancillary data should be managed.

corruption. First, all operations in an application are logically taken on a copy of the current dataset. If the dataset was good, that is, in database terms had “integrity,” we do not want to overwrite it until we have achieved integrity in the copied version. When that state is achieved in the eyes of the user, an application can ask to SAVE the modification, or in a database, we execute a COMMIT. In both of these cases the initial write is done first to a new place in

storage (in case there is a power outage during the write), then the directory reference is shifted from the old to the new version of the file. This transaction approach is designed to address power outages, disk corruption, errors in programs, and other issues that can corrupt a dataset (but not user error). Most applications today rely on this protocol.

Transactions are easy for single-user applications and for updates that can address the whole file. Of course your bank's database and soon your project's database has no notion of a whole file but rather varying levels of granularity upon which transactions apply—at the project, building, object, or potentially even attribute set levels of granularity. Also, we may have dozens of users. ATMs make bank database transactions using simple locking mechanisms that only allow access to your account information serially. That is, you and others who share your account can only act on it one at a time. This works because your transactions—involving both read (current balance) and write (withdrawal or deposit)—take only a few seconds. The recognition that the time between reading engineering data and later writing it may take several hours or a day introduced new transaction problems, classified as “long transactions” (Gray and Reuter 1992). In general, guaranteeing the integrity of design, engineering, and construction transactions with a building model server using concurrent, long transactions is a fundamental requirement for a building or product model server. Transaction capabilities are fundamental, and apply to single, parallel, or “cloud” configurations of servers.

A transaction is both the unit of change and also a unit of consistency management (or synchronization). A system's transaction management system determines how concurrent work is undertaken and managed, for example, by managing partitions of the building model at different levels of granularity (which might be a file, a floor level, or a set of objects). The information granules may be locked allowing only single users to write, or allowing sharing by multiple users to write data but with automatic notification of updates, and other concurrency management policies. These will become more important as we move to object-level management of data, potentially allowing high levels of concurrency. Today, most transactions are directly initiated by human users and only apply to a file system or server. But many engineering database transactions will become *active*, in that they may fire automatically, for example, to identify a change in read-only objects being used by others, or to update a report when the data the report was based on has been updated.

An important goal capability of a BIM server is *project synchronization*. While change management means that manual or interactive methods identify when files may not be consistent and may require revision as the result of other changes, synchronization means that all the various heterogeneous

project files are maintained so as to be consistent with one another. It is a fundamental aspect of model integrity, but is now largely managed manually.

While a single parametric model platform and the generation of multiple 2D drawing views and schedules resolves synchronization among a set of drawings derived from the same model, it does not resolve the case involving multiple functionally different models running on tools that are derived from the platform model. Even less easily synchronized are multiple platforms' models, say, used in different fabrication processes on the same project. Here, synchronization addresses all the coordination issues among the different systems, including spatial clashes, intersystem connections and load transfers between systems (energy loads, structural loads, electrical or fluid flow loads). Synchronization across heterogeneous models is largely carried out manually but is one of the major benefits of an effective BIM repository. Manual methods of data consistency management have been relied on, but are onerous, as they help only a little when it is known that the information in one file depends on the contents of another file. Human management based on objects (carried in one's head) does a better job. But if synchronization is to be realized at the object level, with millions of objects, manual maintenance is not practical and automatic methods will have to be implemented and relied upon. It should be noted that the updating associated with synchronization cannot yet be fully automated, as many revisions to achieve consistency involve design decisions; some aspects of synchronization require person-to-person collaboration. So automatic synchronization can only now be achieved in degrees.

A framework that allows object-level coordination across heterogeneous project models generated by different products is required to achieve any level of synchronization, manual or automated. Such a framework has implications for the modeling tools integrated. All objects need to carry timestamps and global IDs. Global Unique IDs (GUIDs) identify an object regardless of what application is using it, so that updates can be synchronized across heterogeneous applications and potentially allow aspects of objects to be updated by different users, a sometimes important requirement. Consider a collaborating architect and energy analyst; the analyst is likely to be assigning material properties to a model prepared by the architect. The analyst is changing data that may affect other model properties, such as those for acoustic assessment. GUIDs allow reliable tracking and management of such changes. The timestamps are updated whenever a file is modified and allows tracking of the most recent version. GUIDs and timestamps are examples of the metadata carried in a building model. *Metadata* was coined as a term to address "the data about the data," allowing it to be managed.

**Table 3–3** Synchronization of Object Metadata for a Selected Set of BIM Platforms

<b>BIM Platform</b>	<b>Manage Unique IDs</b>	<b>Manage Timestamp</b>
Revit, Release 2011	Has a tag object that can carry ID at the object instance level	At the file level
Bentley	At the object instance level	Modification marks carried in object
ArchiCad	At the object instance level	At the object instance level
Vectorworks	No support	No support
Digital Project, V1, R4, SP 7	At the object instance level	At the object instance level
Tekla	At the object instance level	At the object instance level

These capabilities require that any application that can create, modify, or delete the design or engineering data must support:

- Creation of new GUIDs and timestamps, whenever a new object is created (or stored) or exported
- Reading the GUIDs and timestamps with imported objects and carrying this data for later export
- Exporting the timestamp and GUID data with other exported data and objects that have been created, modified, or deleted

In Chapter 2 we listed the information needed for object-level version management—here, what we have called synchronization. In Table 3–3 we identify the ability of the BIM authoring tools to support object-level change management.

These criteria apply to all data that will be managed by a server, whether using IFC or not. That means that it applies to most BIM tools, as well as platforms. If a quantity takeoff application extracts a set of quantities from a BIM model, the timestamps on the quantities will determine their later version validity. When a product specification is changed in a spec-writing application for some component, say, a set of windows, that change may affect quantities of different window types, installation requirements, detailing, and other aspects. The change needs to propagate to all affected information. Given the tracking of the version of all object instances makes it possible for automatic management of synchronization.

Synchronization guarantees that all data has been checked to be consistent up to the most recent timestamp. Synchronization is not addressed in the middle of some design activity, such as when one temporarily saves current files at

dinner time. It applies only when changes are considered adequate for external sharing and review. These are when Commits are made. Objects that are not current, not synchronized, should not have their data exported to other systems. This may result in propagating erroneous data; only fully synchronized objects should be the basis for exchanges. Status flags are often carried at the object level in order to distinguish temporary updates from complete transactions, and also objects lacking synchronization. Based on such status information, a background transaction identifies what objects have been created, modified, or deleted, and identifies what other files have those objects within them. Alternative mechanisms can be applied to flag the affected objects in the different application datasets. After identifying the potential inconsistencies, the type of synchronization transaction determines which are manual and which are automated:

1. **Automatic Partial Updates:** Many derived object views are simple and can be updated automatically. This class of synchronization transaction automatically updates those objects whose view is inconsistent with the exchange capabilities within the BIM server. These would apply to geometric changes of B-rep shapes, the generation of BOMs and other schedules, and attribute changes. The updated objects would also have their timestamps updated, possibly leading to additional automated or manual updates.
2. **Assigned Action Items:** Where automatic updates are not deterministic, a manual update transaction is required, such as for some types of clash detection. Here, each user receives a list of objects he or she is responsible for that need to be reviewed because of clash checks and possibly updated. After the corrections have been made, the transaction is considered complete. This is the lowest level of synchronization enforcement.

Initially, synchronization will be mostly manual, but as time progresses, methods will be developed to automatically derive updated views of modified objects. Synchronization can be extended, for example, to include automatic clash detection, where the clash is between a clearly dominant object and a subsidiary one. This is likely to be an early example of an automated synchronization transaction.

### 3.5.2 Functionality of BIM Servers

All BIM servers need to support access control and information ownership. They need to support the range of information required of its domain of

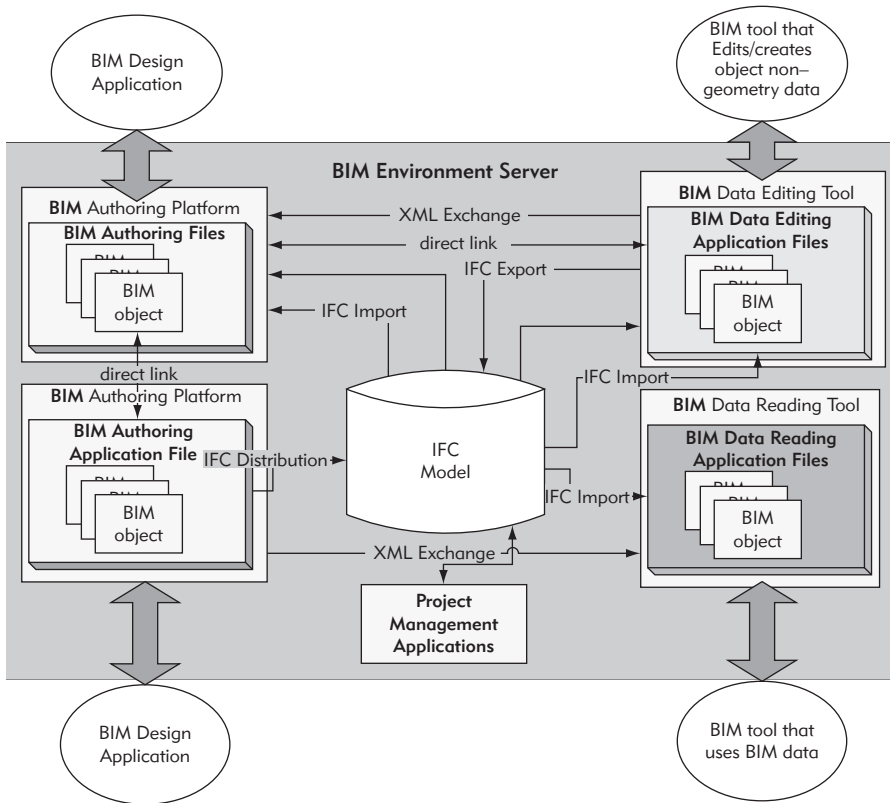
application. We believe that the BIM server market consists of multiple markets, at least three, based on their different functionality:

1. A design-engineering-construction project-oriented market; this is the kernel market and will be developed in more detail below; it is project-oriented, needs to support a wide range of applications, and be able to support change management and synchronization.
2. A made-to-order plant-management market, primarily applied to engineered-to-order products, such as steel fabrication, curtain walls, escalators, and other prefabricated units for a given project. However, this system must track multiple projects and facilitate production coordination across them. This market is similar to the small business Product Lifecycle Management (PLM) systems market.
3. A facilities operation and management product, addressing the monitoring of facility operations, possibly capturing sensor data from one or more facilities, with real-time monitoring and lifetime commissioning.

Each of these markets will grow to maturity in the next decade, responding to their different uses and functionality, responsible for managing different types of data.

Here, we address the needs of the first of the three uses listed above: a project-centric design, engineering, and construction server. It is probably the most challenging, with many diverse applications. In practice, each design participant and application is not involved with the complete representation of the building's design and construction. Each participant is interested in only a subset of the building information model, defined as particular views of the building model. Similarly, coordination does not apply universally; only a few users need to know reinforcing layouts inside concrete or weld specifications. Drawings were naturally partitioned and model servers will follow that tradition, with model views as their specifications where synchronization must take place.

The general system architecture and exchange flows of an idealized BIM server are shown in Figure 3–10. BIM server services are complicated by the challenges of storing the required data in the appropriate format to archive and recreate the native project files required by the various BIM authoring and user tools. Neutral formats are inadequate to recreate the native data formats used by applications, except in a few limited cases. These can only be recreated from the native application datasets themselves, due to the basic heterogeneity of the built-in behavior in the parametric modeling design tools (described in Chapter 2 Section 2.2.1. Thus any neutral format exchange information, such

**FIGURE 3-10**

Example internal structure of exchanges supported by a BIM server.

In order to support synchronization, all BIM tools must be able to be accessible and checked by the server. Active transactions communicate between applications to define project/user action items. In some cases, active transaction may initiate updates. The synchronization management system is controlled by the BIM administrator.

as IFC model data, must be augmented by or associated with the native project files produced by the BIM authoring tools. The requirements and exchanges shown in Figure 3-10 reflect the mixed formats that have to be managed.

Future areas where repositories are expected to provide important automated synchronization services include: dataset preparation and pre-checking for multiple types of analyses, such as energy analyses of building shell, of interior energy distribution and mechanical equipment simulation; bills of material and procurement tracking; construction management; building commissioning; and facility management and operations. Also, these server capabilities will also be able to check project models to determine if they fulfill information requirements to meet various milestones, such as construction tendering model or owner pass-off upon completion.

While potential candidate BIM servers can be assessed in terms of the above capabilities, other considerations, regarding application integration, training, and support required, are all part of the ROI calculation.

### 3.5.3 BIM Server Review

Some of the existing BIM server products are young and their systems architectures and functionality are still developing. Most do not yet respond to the BIM server needs of object-level management. Other server products are being adapted from other application domains for the AEC market. As a result their functionality is changing with each release. A broad list and quick overview of most products in this industry are listed below. We start with the BIM design tool products.

**Autodesk Collaborative Project Management** incorporates Buzzsaw and ConstructWare, both Web-based accessible on-demand project management systems, developed in 2000. Together they support document management with project-related document and contract tracking; version control and search capabilities; design management with automatic notifications of design changes; reference file management; cost management with budget and expenditure tracking and forecasting; data exchange with accounting systems to enable tracking of individual projects; construction management with notification of RFIs, transmittals, meeting minutes, change orders, and reporting; and project management dashboards. Data is managed at the file level and does not support object-level management.

**Bentley ProjectWise Integration Server** is a well-developed and popular base server platform that provides central capabilities for a single office or distributed services for an enterprise or team project. For distributed services, it relies on cached servers providing fast local services for project files. The ProjectWise Server provides version control of reference files so that any XREF files are flagged if not up to date. Web versions are also available. Unit of management is a file, not an object. Integration Server can be augmented with additional services defined below.

**i-Model** is an extensible XML format with its own schema for publishing DGN and other Bentley data. A plug-in for generating i-Model data from Revit is also available. i-Model data can be derived from STEP models including CIS/2, IFC, and ISO 15926, as well as DWG and DGN file formats. This provides a platform for markup and review, and for integrating applications within Bentley and with their System Development Kit (SDK) and for third-party applications. It also includes generation of 3D PDF format.

**ProjectWise Navigator** provides an overlay display capability for dealing with heterogeneous project files. Handles DGN, i-Model, PDF, DWG, and DGN overlays; uses indices to key files for access and viewing. Incorporates internal applications for multiproduct clash detection, allows grouping for



managing product data, for purchases, review, and so forth. It supports 4D simulation, rendering, and markups for review but only limited editing. The ProjectWise products do not yet provide object-level management of data, although Bentley has had earlier products with this capability.

**BIM Server** (an open source server)—from TNO Netherlands and TU of Eindhoven, [www.bimserver.org/](http://www.bimserver.org/)—supports import/export of IFC which is the basis of the BIMserver open standards. This includes incremental updates and change management. It provides an easy-to-use (Web) user interface with an IFC viewer client ([www.ifcbrowser.com/](http://www.ifcbrowser.com/)). It provides IFC versioning, and can go back in time and see who made what changes and when. It supports Filter & Query such as “get only the windows from a model,” or “get one specific wall” using direct Objectlinks. It has a Web service client for exploration of the BIMserver. It has SOAP (Simple Object Access Protocol) and REST (which supports URL-based object access) for the Web service interface. Mostly written in java, it currently runs on Oracle, using BerkeleyUnix. RSS feeds are provided for real-time change alerts. It includes some support for IFD. It is developing a clash detection embedded application. It supports CityGML export of IFC Models to CityGML ([www.citygml.org/](http://www.citygml.org/)), including the BIM/IFC-Extension ([www.citygmlwiki.org/index.php/CityGML\\_BIM\\_ADE](http://www.citygmlwiki.org/index.php/CityGML_BIM_ADE)). Several client applications are based on BIM Server: clash detection, rendering, gbXML energy interface, KML, and SketchUp export to Google Earth, XML export, and COBie export for construction operations handover. This is a true shareware system with a user development team and source code access.

**Drofus** is a Web-accessible SQL database that addresses the spaces within any building and the equipment within the spaces. It is thus not a complete building model server addressing all aspects of a project, but rather a model view dealing with spaces, their furnishings and finishes. It can start with the programming phase to define the requirements for equipment and furniture, then the design and layout, in quantitative terms. It supports spatial program review by two-way exchanges with BIM authoring tools through IFC. Equipment, finishes, and material definitions can be linked to automatic ordering and tracking, including procurement. At the end, the system can be used for operations and facility management. Drofus carries object IDs and supports synchronization between itself and the building model ([www.drofus.no/](http://www.drofus.no/)). Drofus has been used in production for several years and is quite mature and is especially relevant for building types where equipment support is a fundamental part of the design program, such as hospitals and laboratories.

**EuroSTEP Share-A-Space Model Server** is a model server initially developed for aerospace, being adapted to AEC; uses Oracle (soon also Windows SQL Server) as its host database. It is an object model server that relies on IFC as internal representation but also supports native models at the file level; it applies ISO10303-239 STEP and the OGC Product Life Cycle Support (PLCS) schema for change management, versioning, consolidation, requirements, status, and so forth. It uses MS Biztalk for XML-based communication and incorporates a Web client portal. It supports strong business process capabilities, for part and product entities, testing, and requirements, status, and people-tracking. It includes email services and has interesting workflow capabilities; it includes a Mapper function that translates one object view to another, implemented in XML and C#; its imports can have associated rules that apply to change updates that can be automatic, partial, or manual. It incorporates Solibri Model Checker, for applications and requirements checking; also uses VRML for visualization. This PLM-type system is being adapted to AEC applications.

**Graphisoft ArchiCad BIM Server.** ArchiCad Version 13 and 14 provides Web server project management with simple project access control, version and change management for ArchiCad and IFC-based projects. It is the first major BIM design platform with a backend database whose unit of management is objects rather than files. This allows selecting objects to work on, while the BIM server manages those accesses and access locks. In most cases, object reading and use of reference objects for context greatly reduces the scope of each transaction. Updates then are limited to those objects actually modified, reducing file transfer size and the time it takes to make the updates. All users can graphically see what other users have reserved. Updates are trimmed of unchanged objects and called Delta updates. Synchronization is an important issue—when are the changes to one object propagated to others that may not be reserved? ArchiCad provides three options: real-time and automatic when objects are selected and worked on without checking them out; semi-automatic synchronization for the objects checked out and modified, only for those objects requested; or on-demand. It supports the use of 2D DXF files for coordination.

**Horizontal Glue™** is a Web-based server with its own lightweight geometry viewer that can automatically translate and view objects from multiple BIM platforms (currently Revit, and IFC; Bentley is coming). This greatly facilitates collaboration. It supports management of IFC and native files. It supports both its own and Navisworks' clash detection; its particular strength is providing open communication links and change record

tracking; it incorporates cost estimation and project tracking through Prolog, and Proliance® for lifecycle management. This is a young startup, with much ambition.

**Jotne EDM Model Server** supports any Express language schema, with a full implementation of Express and any EXPRESS schema, such as IFC and CIS/2. It includes multilanguage support (spoken language) with IFD. It supports Express-X, an ISO model mapping language that allows mapping between EXPRESS schemas. This could be used to map between model views or ISO-15926, for example. Express-X also supports rule checking and interfaces to applications on the server. It uses MVDs as one of multiple query/access modes. It supports both TCP and HTTP, for direct and Web interfaces. It has limited version control, allows object-level access and updates; updates always overwrite the stored version. Selection for checkout is limited (Jørgensen et al. 2008).

**Oracle Primavera and AutoView** ([www.oracle.com/us/products/applications/autovue/index.htm](http://www.oracle.com/us/products/applications/autovue/index.htm)) Primavera on Oracle enables organizations running Primavera P6 project cost, schedule, and resource requirements with Oracle's project and portfolio system and plant maintenance information. It supports storage of native platform files for check-out and check-in. It is not an object-level BIM manager. It addresses multiple markets including production plant management for engineered-to-order products (steel and precast fabrication, curtain wall systems) (see Chapter 7). It supports 3D PDF and AutoView, a lightweight 2D drawing and 3D model viewer for review and walkthroughs. It supports accurate spatial measurements and 3D identification of clashes.

Other industries have recognized the need for product model servers. Their implementation in the largest industries—electronics, manufacturing, and aerospace—has led to a major industry involving Product Lifecycle Management (PLM). These systems are generally adapted through custom software engineered for a single company and typically involve system integration of a set of tools including product model management, inventory management, material and resource tracking and scheduling, among others. They rely on supporting model data in one of a few proprietary native formats, possibly augmented by ISO-STEP-based exchanges. Examples include Dassault V6 2.0 PLM, SAP PLM, and SmarTeam, adapted for construction by Technia. These have penetrated only the largest businesses, because the current business model of PLM is based on system integration services. What is lacking is a ready-to-use product that can support medium- or small-scale organizations that dominate the

makeup of construction industry firms. Thus the medium and small industries—in both construction and manufacturing—are waiting for PLM systems that can be easily tailored for various kinds of use.

---

### 3.6 SUMMARY

The AEC field is learning what kind of information is needed for different tasks, what is important for effective workflows, and how to document the required information. Second, it has learned that most applications rely on fixed (noneditable) geometry and only a few need to create or edit geometry data. We are learning that interoperability in most cases can be made straightforward. Various XML schemas are being used for a growing number of businesses and some analysis exchanges, and these are also expanding into design-type exchanges. We expect to see these exchanges grow, especially for incremental updates. The need for explicit exchange standards is becoming recognized and such standards will become used in the definition of project-scale business practices. The BIM platform developers will continue to offer packaged solutions, while reliance on IFC will grow to provide workflows not well supported by the software vendors. The trend to IFC will hopefully grow as robust MVDs are defined and implemented. In parallel, the need to gain help managing heterogeneous data from diverse platforms in complex projects is increasingly recognized as a major productivity problem. BIM servers are becoming a new market. With BIM servers, different exchanges, whether proprietary, through open standards, or manual, become steps in the workflow for the project. All approaches are expected to coexist, with different mappings being adopted as small technology increments.

---

## Chapter 3 Discussion Questions

---

1. What are the major differences between DXF as an exchange format and an object-based schema like IFC?
2. Choose a design or engineering application that has no effective interface with a BIM design tool you use. Identify the types of information the BIM design tool needs to send to this application.
3. Extend this to think what might be returned to the BIM design tool, as a result of running this application.

4. Take a simple design of some simple object, such as a Lego® sculpture. Using IFC, define the IFC entities needed to represent the design. Check the description using an EXPRESS parser, such as the free EXPRESS-O checker available from the Sourceforge open software Web site.
5. For one or more of the coordination activities below, identify the information that needs to be exchanged in both directions:
  - a. Building design that is informed by energy analysis of the building shell
  - b. Building design that is informed by a structural analysis
  - c. Steel fabrication level model that coordinates with a shop scheduling and materials tracking application
  - d. Cast-in-place concrete design that is informed by a modular formwork system
6. What are the distinguishing functional capabilities provided by a building model repository and database as compared to a file-based system?
7. Explain why file exchange between design systems using IFC can result in errors. How would these errors be detected?
8. You are manager of a BIM repository that has both a structural analysis model and an energy analysis model. You make a change in placement to the physical (architectural intent) model. How should the synchronization process work so as to make the BIM environment model consistent?



# CHAPTER 4

---

## BIM for Owners and Facility Managers

---

### 4.0 EXECUTIVE SUMMARY

Owners can realize significant benefits on projects by using BIM processes and tools to streamline the delivery of higher quality and better performing buildings. BIM facilitates collaboration between project participants, reducing errors and field changes and leading to a more efficient and reliable delivery process that reduces project time and cost. There are many potential areas for BIM contributions. Owners can use a building information model to:

- **Increase building performance** through BIM-based energy and lighting design and analysis to improve overall building performance
- **Reduce the financial risk** associated with the project using the BIM model to obtain earlier and more reliable cost estimates and improved collaboration of the project team
- **Shorten project schedule** from approval to completion by using building models to coordinate and prefabricate design with reduced field labor time

- **Obtain reliable and accurate cost estimates** through automatic quantity takeoff from the building model, providing feedback earlier in a project when decisions will have the greatest impact
- **Assure program compliance** through ongoing analysis of the building model against owner and local code requirements
- **Optimize facility management and maintenance** by exporting relevant as-built building and equipment information to start the systems that will be used over the lifecycle of the facility

These benefits are available to all types of owners on almost all types of projects, however, it is clearly the case that owners have yet to realize all of the benefits associated with BIM or employ all of the tools and processes discussed in this book. Significant changes in the delivery process, selection of service providers, and approach to projects are necessary to fully realize BIM's benefits. Today, owners are rewriting contract language, specifications, and project requirements to incorporate the use of BIM-based processes and technologies into their projects as much as possible. Most owners that have initiated and/or participated in BIM efforts are reaping advantages in the marketplace through the delivery of higher value facilities and reduced operational costs. In concert with these changes, some owners are actively leading efforts to implement BIM tools on their projects by facilitating and supporting BIM education and research.

---

#### 4.1 INTRODUCTION: WHY OWNERS SHOULD CARE ABOUT BIM

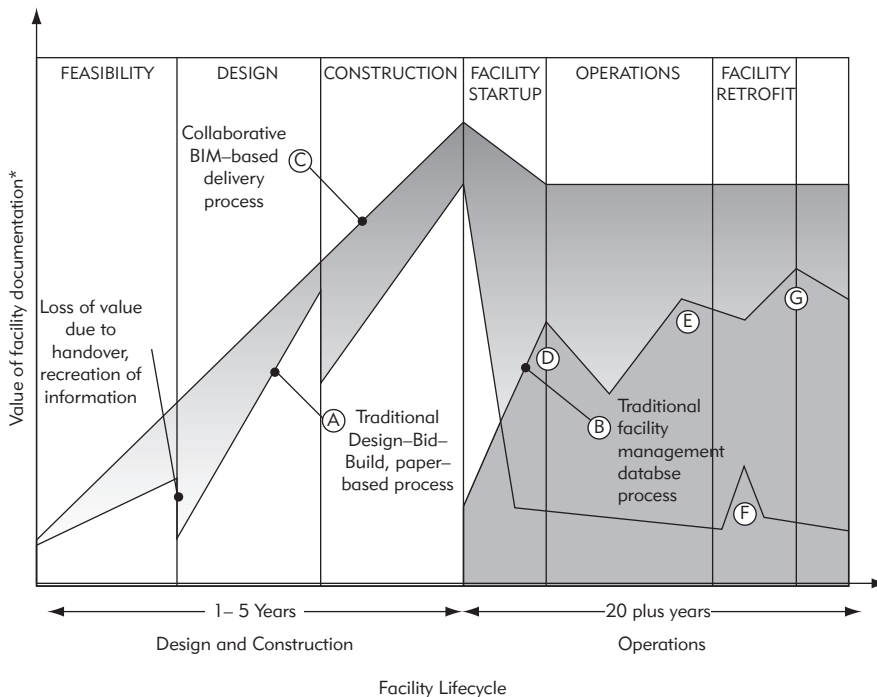
Lean processes and digital modeling have revolutionized the manufacturing and aerospace industries. Early adopters of these production processes and tools, such as Toyota and Boeing, have achieved manufacturing efficiencies and commercial successes (Laurenzo 2005). Late adopters were forced to catch up in order to compete; and although they may not have encountered the technical hurdles experienced by early adopters, they still faced significant changes to their work processes.

The AEC industry is facing a similar revolution, requiring both process changes and a paradigm shift from 2D-based documentation and staged delivery processes to a digital prototype and collaborative workflow. The foundation of BIM is one or more coordinated and information-rich building models with capabilities for virtual prototyping, analysis, and virtual construction of a project. These tools broadly enhance today's CAD capabilities with an improved ability to link design information with business processes, such as estimating,



sales forecasts, and operations. These tools support a collaborative rather than fragmented approach to project procurement. This collaboration builds trust and common goals that serve the owner rather than competitive relationships where each team member strives to maximize their individual goals. In contrast, with drawing-based processes, analyses must be done independently of the building design information, often requiring duplicate, tedious, and error-prone data entry. The result is loss of value in information assets across phases, many more opportunities for errors and omissions, and increased effort to produce accurate project information, as the conceptual diagram in Figure 4–1 shows. Consequently, such analyses can be out of sync with design information and lead to errors. With BIM-based processes, the owner can potentially realize a greater return on his or her investment as a result of the improved integrated design process, which increases the value of project information in each phase and allows greater efficiency for the project team. Simultaneously, owners can reap dividends in project quality, cost, and future operation of the facility.

The new Integrated Project Delivery (IPD) approach to procuring construction projects (introduced in Chapter 1, Section 1.2.4) aims to achieve close collaboration among all members of a project team. BIM has proved to



**FIGURE 4-1**

(A) Traditional single-stage drawing-based deliverables, (B) traditional facility management database system, (C) BIM-based deliverables throughout the project delivery and operation process, (D) setup of facility management (FM) database, (E) integration of FM with back-office systems, (F) use of "as-built" drawings for retrofit, and (G) update of FM database.

\* slope of line communicates effort to produce and maintain information

- D) Setup of facility management database
- E) Integration of FM with back-office systems
- F) Use of 'as-built' drawings for retrofit
- G) Update of facility management database

be a key enabling technology for IPD teams. The owner's role in initiating and sustaining IPD projects is central and critical, and starts with the first project contract, sometimes called the "Integrated Agreement for Lean Project Delivery" (IFOA) (Mauck et al. 2009). There are also standard IPD contracts published by the AIA and ConsensusDocs (ConsensusDocs 300 series). An excellent discussion of how IPD can support owners' needs with an analysis of contractual issues can be found in a paper by a team of lawyers who have considerable experience with this form of project procurement (Thomsen et al. 2009).

The IPD contract usually defines the BIM software tools the various team members will use, and the information-sharing server solutions the project will support for the benefit of the project as a whole. Under IPD contracts, the owner plays an active role through the life of the project, taking part in decision-making at all levels. BIM tools are essential for owners to understand the intent and the considerations of the designers and builders who make up the IPD team. IPD is discussed further in Chapters 5, 6, and 8 (Sections 5.2.1, 6.11, and 8.3, and are described in detail in the Sutter Medical Center case study in Chapter 9.

This chapter discusses how owners can use BIM to manage project risk, improve project quality, and deliver value to their businesses. It also shows how facility managers can use BIM to better manage their facilities. Owners here are the organizations that initiate and finance building projects. They make strategic decisions in the facility delivery process through the selection of service providers and the type of delivery processes they use. These decisions ultimately control the scope and effectiveness of BIM on a project.

The chapter begins with a discussion of BIM applications for all types of building owners and facility managers. Section 4.3 provides a guide to BIM tools that are suitable or better oriented for owners. Most of the BIM tools available today are targeted toward service providers, such as architects, engineers, contractors, and fabricators; they are not specifically targeted for owners. Other tools are discussed in Chapters 5, 6, and 7, and references are provided for those sections. Section 4.4 discusses the owner's building information model and how the owner's perspective of it and the scope and level of detail may differ from those discussed in subsequent chapters.

Owners play a significant education and leadership role in the building industry. They are the purchasers and often the operators of the AEC industry's products. Section 4.5 discusses different ways for owners to implement BIM applications on their projects, including prequalification of service providers, education and training seminars, guidelines for developing contractual requirements, and changing their internal processes. Section 4.6 follows with a discussion of the risks and the process and technology barriers associated with

BIM implementation. The chapter concludes with guidelines for successful implementation.

---

## 4.2 BIM APPLICATION AREAS FOR OWNERS

Traditionally, owners have not been agents of change within the building industry. They have long been resigned to typical construction project problems, such as cost overruns, schedule delays, and quality issues (Jackson 2002). Many owners view construction as a relatively small capital expenditure compared to the lifecycle costs or other operational costs that accrue over time. Changing marketplace conditions, however, are forcing owners to rethink their views and place greater emphasis on the building delivery process and its impact on their business (Geertsema et al. 2003; Gaddie 2003).

The firms that provide services to owners (AEC professionals) often point to the short-sightedness of owners and the frequent owner-requested changes that ultimately impact design quality, construction cost, and schedule.

Because of the considerable potential impact that BIM can have on these problems, the owner is in the position to benefit most from its use. Thus, it is critical that owners of all types understand how BIM applications can enable competitive advantages and allow their organizations to better respond to market demands and yield a better return on their capital investments. In those instances in which service providers are leading the BIM implementation—seeking their own competitive advantage—educated owners can better leverage the expertise and know-how of their design and construction team.

In the following sections, we provide an overview of drivers that are motivating all types of owners to adopt BIM technologies, and we describe the different types of BIM applications available today. These drivers are:

- Design assessment early and often
- Complexity of facilities
- Time to market
- Cost reliability and management
- Product quality, in terms of leakages, malfunctions, unwarranted maintenance
- Sustainability
- Asset management

Table 4–1 summarizes the BIM applications reviewed in this chapter from the owner’s perspective and the respective benefits associated with those

**Table 4–1** Summary of BIM Application Areas and Potential Benefits to All Owners, Owner-Operators, and Owner-Developers; and a Cross-Reference to Case Studies Presented in Chapter 9

<b>Book Section</b>	<b>Specific BIM Application Areas for Owner (referenced in this chapter)</b>	<b>Market Driver</b>	<b>Benefits to All Owners</b>	<b>Relevant Case Study (CS) or Reference</b>
Chapter 5: Designers and Engineers	Space planning and program compliance	Cost management; marketplace complexity	Ensure project requirements are met	Helsinki Music Hall
	Energy (environmental) analysis	Sustainability	Improve sustainability and energy efficiencies	Marriott Hotel Renovation Helsinki Music Hall
	Design configuration/ scenario planning	Cost management; complexity of building infrastructure	Design quality communication	Aviva Stadium Coast Guard Facility Planning
	Building system analysis/simulation	Sustainability	Building performance and quality	Marriott Hotel Renovation Helsinki Music Hall 100 11th Ave., New York City
	Design communication/ review	Marketplace complexity and language barriers	Communication	All case studies
Chapters 5 and 6: Designers, Engineers, Contractors	Quantity takeoff and cost estimation	Cost management	More reliable and earlier estimates during the design process	Hillwood Commercial Project, Dallas Sutter Medical Center
	Design coordination (clash detection)	Cost management and infrastructure complexity	Reduce field errors and reduce construction costs	Sutter Medical Center One Island East Office Tower, Hong Kong
Chapters 6 and 7: Contractors and Fabricators	Schedule simulation/4D	Time to market, labor shortages, and language barriers	Communicate schedule visually	One Island East Office Tower Crusell Bridge, Finland
	Project controls	Time to market	Track project activities	Sutter Medical Center
	Prefabrication	Time to market	Reduce onsite labor and improve design quality	Sutter Medical Center 100 11th Ave., New York City Aviva Stadium, Dublin Crusell Bridge, Finland
Chapter 4: Owners	Pro forma analysis	Cost management	Improve cost reliability	Hillwood Commercial Project, Dallas
	Operation simulation	Sustainability/Cost management	Building performance and maintainability	Sutter Medical Center Helsinki Music Hall
	Commissioning and asset management	Asset management	Facility and asset management	Coast Guard Facility Planning, various locations Maryland General Hospital, Philadelphia

applications. Many of the applications referenced in this chapter are elaborated on in greater detail in Chapters 5, 6, and 7, and in the case studies presented in Chapter 9.

### 4.2.1 Design Assessment

Owners must be able to manage and evaluate the scope of the design against their own requirements at every phase of a project. During conceptual design, this often involves spatial analysis. Later on, this involves analyses for evaluating whether the design will meet its functional needs. Today, this is a manual process, and owners rely on designers to walk through the project with drawings, images, or rendered animations. Requirements often change, however, and even with clear requirements, it can be difficult for an owner to ensure that all requirements have been met.

Additionally, an ever increasing proportion of projects involve either the retrofit of existing facilities or building in an urban setting. These projects often impact the surrounding community or users of the current facility. Seeking input from all project stakeholders is difficult when they cannot adequately interpret and understand the project drawings and schedule. Owners can work with their design team to use a building information model to:

#### **Integrate development of programmatic requirements**

During the programmatic and feasibility phase, owners, working with their consultants, develop programs and requirements for projects. They often perform this process with little feedback with respect to feasibility and costs of various programmatic features or project requirements. One potential tool to facilitate this process is BIMStorm, an environment and process developed by Onuma Systems, which allows owners and multiple participants and stakeholders to conceptualize a project, solicit input from multiple sources, and assess in real time various design options from cost, time, and sustainability perspectives. Figure 4–2, for example, shows one of these sessions. The team develops a conceptual building model to develop in real time a realistic program.

#### **Improve program compliance through BIM spatial analyses**

Owners such as the United States Coast Guard are able to do rapid spatial analyses with BIM authoring tools (See Coast Guard Facility Planning case study in Chapter 9). The case study includes figures demonstrating how a building model can communicate in real time both spatially and in data form, to check compliance with requirements. Different colors are automatically assigned to rooms based on their dimensions and function.

**FIGURE 4-2**

A team working remotely with other teams via the Web to quickly develop and assess design alternatives using the Onuma System (OS) during a BIMStorm event. OS allows participants to provide input, develop alternatives, and assess a proposed design from multiple perspectives to develop more realistic programmatic requirements that align with the owner's budget and overall project requirements.

Image provided courtesy of Onuma Systems and the Computer Integrated Construction Research Program at Penn State.



In some cases, the color-coding can alert designers or owners of rooms that exceed or don't meet existing requirements. This visual feedback is invaluable during conceptual and schematic design. Thus, the owner can better ensure that the requirements of their organization are met and that operational efficiencies of the program are realized.

#### **Receive more valuable input from project stakeholders through visual simulation**

Owners often need adequate feedback from project stakeholders, who either have little time or struggle with understanding the information provided about a project. Figure 4-3 is a snapshot of judges reviewing their planned courtroom. Figure 4-7 shows a 4D snapshot of all floors of a hospital to communicate the sequence of construction for each department and get feedback on how it will impact hospital operations. In both projects, the building information model and rapid comparison of scenarios greatly enhanced the review process. The traditional use of real-time and highly rendered walkthrough technologies are one-time events, whereas the BIM and 4D tools make what-if design explorations far easier and more viable economically.

#### **Rapidly reconfigure and explore design scenarios**

Real-time configuration, however, is possible either in the model generation tool or a specialized configuration tool. Figure 4-4 shows an



example from the Jacobs Facilities project, where BIM was used to quickly evaluate scenarios and to analyze requirements, needs, budget, and owner feedback (McDuffie 2007).

Another approach specifically targeted to help owners rapidly assess the feasibility of alternative building designs is provided by the DProfiler system developed by Beck Technology. This system provides cost, pro forma, and energy analyses based on conceptual designs. It is discussed in detail in Section 2.6.7 and in further examples in this chapter.

### **Simulate facility operations**

Owners may need additional types of simulations to assess the design quality beyond walkthroughs or visual simulations. These may include crowd behavior or emergency evacuation scenarios. Figure 4–8 shows an example crowd simulation for a typical day at a metro station with related analysis. The simulations used the building information model as a starting point for generating these scenarios. Such simulations are labor intensive and involve the use of specialized tools and services. For facilities where such performance requirements are critical, however, the initial investment in a building information model can pay off due to the more accurate 3D input that these specialized tools require.

## **4.2.2 Complexity of Building Infrastructure and Building Environment**

Modern buildings and facilities are complex in terms of the physical infrastructure and the organizational, financial, and legal structures used to deliver them. Complicated building codes, statutory issues, and liability issues are now common in all building markets and are often a bottleneck or a significant hurdle for project teams. Often, owners must coordinate the design and approval efforts simultaneously. Meanwhile, facility infrastructures have grown increasingly complex. Traditional MEP systems are being integrated with data/telecom, building sensors or meters, and in some cases sophisticated manufacturing or electrical equipment.

BIM tools and processes can support owners' efforts to coordinate the increasingly complex building infrastructure and regulatory process by:

### **Coordinating infrastructure through fully integrated 3D models of MEP, architectural, and structural systems**

A building information model enables virtual coordination of a building's infrastructure across all disciplines. The owner of a facility can include its own representatives from its maintenance and operations staff to provide input and review of the model. Rework due to design flaws can



potentially be avoided. The Crusell Bridge, Sutter Medical Center, and the Helsinki Music Hall projects demonstrate how an owner can work with a construction team to coordinate complex concrete and MEP systems using digital 3D models.

#### **Producing higher-quality and maintainable infrastructure through interactive review of coordinated models**

Many owners need to go beyond typical MEP coordination to ensure that the MEP, data/telecom, and equipment are accessible and maintainable. This is particularly crucial for companies that depend heavily on these systems, such as biotech and technology companies, which demand reliable 24/7 service. Interactive review of the model allows owners to virtually access and simulate maintenance procedures.

#### **Preventing litigation through collaborative creation and sign-off of building information models**

Today, many projects invoke litigation to resolve payment issues due to changes. These issues include: designers citing owner-initiated changes; owners arguing that designers did not meet contractual requirements; and contractors arguing about scope of work and lack of information or inaccurate project documentation. Processes that center on a building model can mitigate such situations simply due to the level of accuracy and resolution necessary for creating a model; the collaborative effort of creating the model often leads to better accountability among project participants.

### **4.2.3 Sustainability**

The green building trend is leading many owners to consider the energy efficiency of their facilities and the overall environmental impact of their projects. Sustainable building is good business practice and can lead to greater marketability of a facility. Building models provide several advantages over traditional 2D models due to the richness of object information needed to perform energy or other environmental analyses. Specific BIM analysis tools are discussed in detail in Chapters 2 and 5. From the owner's perspective, BIM processes can help:

#### **Reduce energy consumption through energy analysis**

On average, energy accounts for \$1.50 to \$2.00 per square foot of operational costs (Hodges and Elvey 2005). For a 50,000 square foot facility, this amounts to \$75,000 to \$100,000 annually. Investment in an energy-saving building system, such as enhanced insulation, reduces energy consumption by 10 percent and translates to \$8,000 to \$10,000 annual savings. The breakeven point for an up-front investment of \$50,000

would occur by the sixth year of operation. The challenge when making such assessments is to compute the actual reduction in energy consumption achievable by any specific design. There are many tools for owners to evaluate the payoff and return on energy-saving investments, including lifecycle analysis, and these are discussed in Chapter 5. While these analysis tools do not absolutely require the use of a building information model for input, a model greatly facilitates their use. The Helsinki Music Hall case study in Chapter 9 demonstrates the kinds of energy conservation analyses that can be integrated using BIM tools.

#### **Improve operational productivity with model creation and simulation tools**

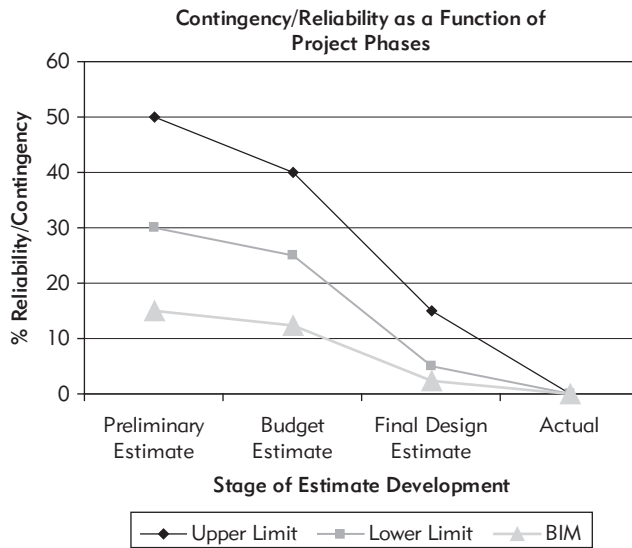
Sustainable design can greatly impact overall workplace productivity. Ninety-two percent of operating costs are spent on the people who work in the facility (Romm 1994). Studies suggest that day-lighting in retail and offices improves productivity and reduces absenteeism (Roodman and Lenssen 1995). BIM technologies provide owners with tools needed for assessing the appropriate tradeoffs when considering the use of day-lighting and the mitigation of glare and solar heat gain, as compared with project cost and overall project requirements. The Helsinki Music Hall case study compared different scenarios to maximize the potential benefits of different glazing systems.

Once the facility is complete, owners can use the building model and design data to monitor energy consumption and compare real-time use.

#### **4.2.4 Cost Reliability and Management**

Owners are often faced with cost overruns or unexpected costs that force them to either “value engineer,” go over budget, or cancel the project. Surveys of owners indicate that up to two-thirds of construction clients report cost overruns (Construction Clients Forum 1997; FMI/CMAA 2005, 2006). To mitigate the risk of overruns and unreliable estimates, owners and service providers add contingencies to estimates or a “budget set aside to cope with uncertainties during construction” (Touran 2003). Figure 4–5 shows a typical range of contingencies that owners and their service providers apply to estimates, which vary from 50 to 5 percent depending on the project phase. Unreliable estimates expose owners to significant risk and artificially increase all project costs.

The reliability of cost estimates is impacted by a number of factors, including market conditions that change over time, the time between estimate and execution, design changes, and quality issues (Jackson 2002). The accurate and computable nature of building information models provides a more reliable source for owners to perform quantity takeoff and estimating and



**FIGURE 4-5** Chart showing the upper and lower limits that an owner typically adds to the contingency and reliability of an estimate over different phases of a project (data adapted from United States 1997; Munroe 2007; Oberlander and Trost 2001) and the potential targeted reliability improvements associated with BIM-based estimating.

provides faster cost feedback on design changes. This is important because the ability to influence cost is highest early in the process at the conceptual and feasibility phase, as shown in Figure 4-6. Estimators cite insufficient time, poor documentation, and communication breakdowns between project participants, specifically between owner and estimator, as the primary causes of poor estimates (Akintoye and Fitzgerald 2000).

Today's use of BIM is typically limited to the late phase of design and engineering or early phases of construction. Use of BIM earlier in the design process will have greater influence on cost. Improving overall cost reliability is a key motivator for employing BIM-based cost estimating methods.

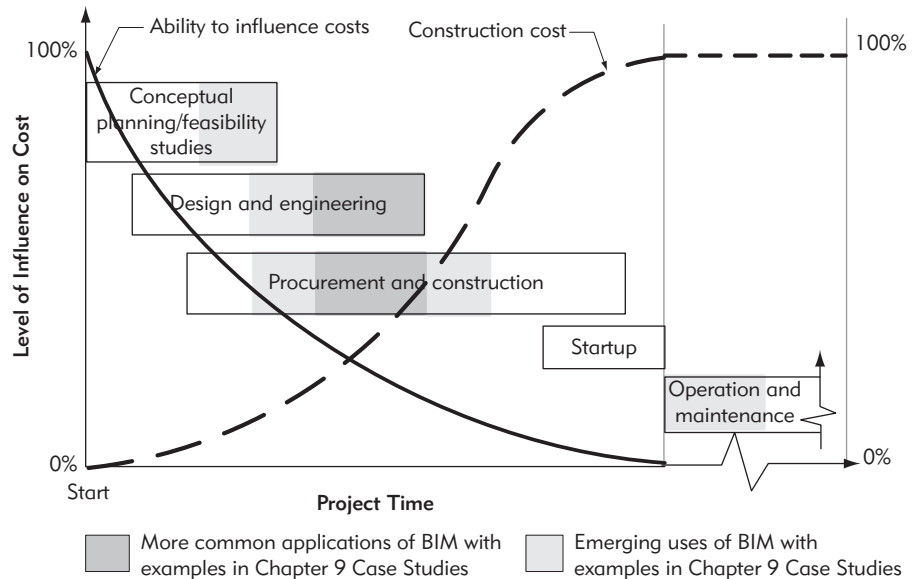
Owners can manage cost with BIM applications to provide:

**More reliable estimates early in the process with conceptual BIM estimating**

Estimates that use conceptual building information models consisting of components with historical cost information, productivity information, and other estimating information can provide owners with quick feedback on various design scenarios. Accurate estimates can be very valuable early in the project, particularly for assessing a project's predicted cash flow and procuring finance. The Hillwood Commercial project case study, discussed in Chapter 9, demonstrates how owners working with a service provider employing a conceptual BIM-based estimating tool called DProfiler are able to reduce overall contingency and reliability and ultimately save money by borrowing less.

**FIGURE 4-6**

Influence of overall project cost over the project lifecycle.



### Faster, better-detailed, and more accurate estimates with BIM quantity takeoff tools

Both owners and estimators struggle with the ability to respond to design and requirement changes and understand the impact of those changes on the overall project budget and estimate. By linking the design model with the estimating processes, the project team can speed up the quantity takeoff and overall estimating process and get faster feedback on proposed design changes (see Chapters 5 and 6). For example, owners can automatically derive accurate quantities and in turn streamline and verify estimates of designers and subcontractors (Rundell 2006). The Hillwood Commercial project case study in Chapter 9 cites evidence that estimating with BIM early in design can result in a 92 percent time reduction to produce the estimate with only a 1 percent variance between the manual and BIM-based processes. In the One Island East Office Tower case study in Chapter 9, the owner was able to set a lower contingency in their budget as a result of the reliability and accuracy of the BIM-based estimate. In the Sutter Medical Center case study, the team performed model-based cost estimating every two to three weeks during design to ensure that the design was kept within the budget.

Owners, however, must realize that BIM-based takeoff and estimating is only a first step in the whole estimating process; it does not thoroughly address the issue of omissions. Additionally, the more accurate derivation

of components that BIM provides does not deal with specific site conditions or the complexity of the facility, which depend on the expertise of an estimator to quantify. BIM-based cost estimation strategically helps the experienced cost estimators but does not replace them.

#### 4.2.5 Time to Market: Schedule Management

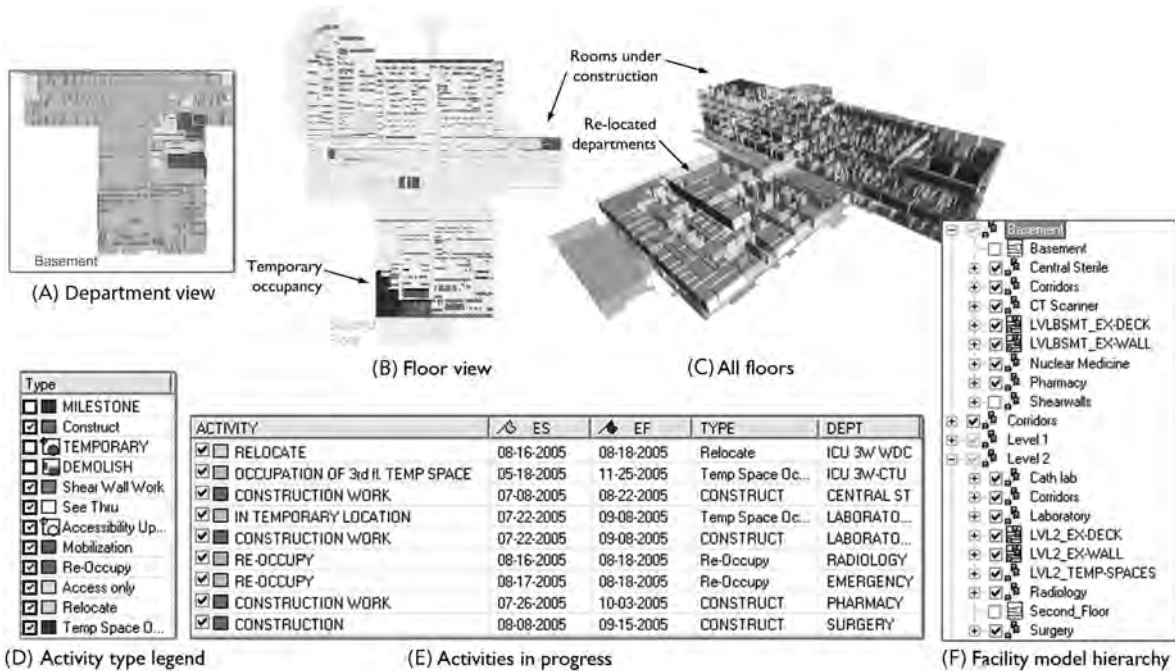
Time to market impacts all industries, and facility construction is often a bottleneck. Manufacturing organizations have well-defined time-to-market requirements, and must explore methods and technologies that enable them to deliver facilities faster, better, and cheaper. BIM provides owners and their project teams with tools to partially automate design, simulate operations, and employ offsite fabrication. These innovations—initially targeted toward manufacturing or process facilities—are now available to the general commercial facility industry and its service providers. The innovations provide owners with a variety of BIM applications to respond to the following time to market needs:

##### **Reduce time to market through the use of parametric models**

Long building cycles increase market risk. Projects that are financed in good economic times may reach the market in a downturn, greatly impacting the project's ROI (Return on Investment). BIM processes, such as BIM-based design and prefabrication, can greatly reduce the project duration, from project approval to facility completion. The component parametric nature of the BIM model makes design changes easier and the resulting updates of documentation automatic. The Flint Global V6 Engine Plant Expansion project was an excellent example of a parametric-based design used to support rapid scenario planning early in a project (it is described in the first edition of the *BIM Handbook*, Section 9.1). This large complex project was designed and built in 35 weeks, which is roughly half of what would have been required for a conventional design-build approach.

##### **Reduce schedule duration with 3D coordination and prefabrication**

All owners pay a cost for construction delays or lengthy projects, either in interest payments on loans, delayed rental income, or other income from sales of goods or products. In the Sutter Medical Center case study in Chapter 9, the owner was under a legal requirement to complete a new hospital that met earthquake standards by the end of 2012. The application of BIM to support early coordination, constructability analysis, and prefabrication led to improved design and field productivity, reduced field effort, and significant reductions in the overall construction schedule, which resulted in a confident forecast of on-time delivery.



**FIGURE 4-7** Views of a 4D model for a nine-floor hospital facility showing concurrent retrofit activities across departments and floors: (A) 4D view of a department; (B) 4D view of a floor; (C) 4D view of all floors; (D) activity type legend showing the types of activities the construction management team and owner communicated in the 4D model; (E) the activities in progress; and (F) the 4D hierarchy showing the organization by floor and department.

Image provided courtesy of URS.

### Reduce schedule-related risk with BIM-based planning

Schedules are often impacted by activities involving high risk, dependencies, multiple organizations, or complex sequences of activities. These often occur in projects such as renovations of existing facilities, where construction must be coordinated with ongoing operations. For example, a construction manager representing the owner used 4D models (see Chapter 6 and Figure 4-7) to communicate a schedule to hospital staff and mitigate the impact of activities on their operations (Roe 2002).

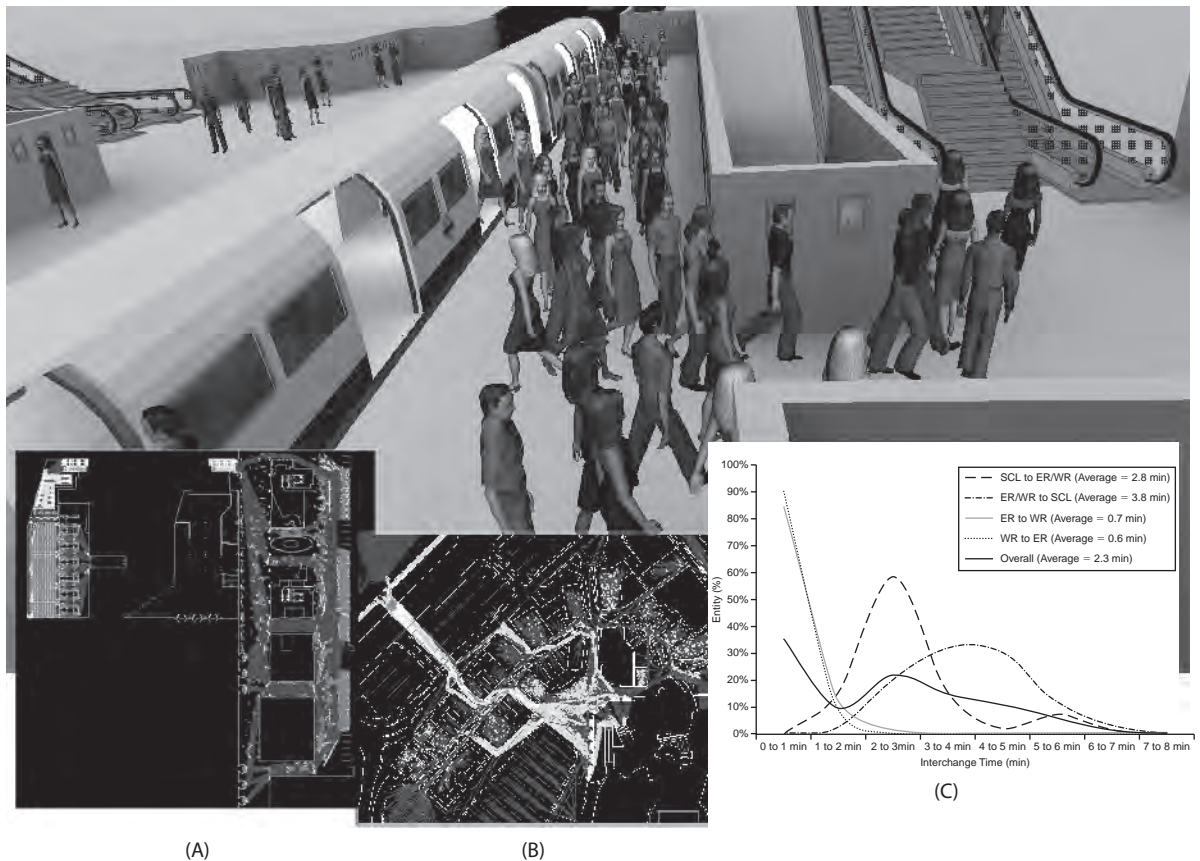
### Quickly respond to unforeseen field conditions with 4D-coordinated BIM models

Owners and their service providers often encounter unforeseen conditions that even the best digital models cannot predict. Teams using digital models are often in a better position to respond to unforeseen conditions and get back on schedule. For example, a retail project was slated to open before Thanksgiving for the holiday shopping season. Three months into

the project, unforeseen conditions forced the project to stop for three months. The contractor used a 4D model (see Chapter 6) to help plan for the recovery and open the facility on time (Roe 2002).

#### 4.2.6 Facility and Information Asset Management

Every industry is now faced with understanding how to leverage information as an asset; and facility owners are no exception. Today, information is generated during each project phase and often reentered or produced during hand-offs between phases and organizations, as shown in Figure 4–1. At the end of most



**FIGURE 4-8** Examples of Legion Studio's visual and analytical outputs based on 2D and 3D building information data. The main 3D rendering shows a simulation of a metro station during a weekday morning peak. (A) A map of an airport uses color to show average speed, with red indicating slow movement and blue indicating free-flowing movement; (B) a map of a stadium with access routes and adjacent retail facilities showing mean density, with red and yellow indicating the locations of highest density; and (C) a graph comparing passenger interchange times between several origin-destination pairs. (See color insert for full color figure.)

Images provided courtesy of Legion Limited.

projects, the value of this information drops precipitously, because it is typically not updated to reflect as-built conditions or in a form that is readily accessible or manageable. Figure 4–1 shows that a project involving collaborative creation and updating of a building model potentially will see fewer periods of duplicate information entry or information loss. Owners who view the total lifecycle ownership of their projects can use a building model strategically and effectively to:

**Commission a building more efficiently**

According to the Building Commissioning Association (see [www.bcxa.org/](http://www.bcxa.org/)), “Building commissioning provides documented confirmation that building systems function according to criteria set forth in the project documents to satisfy the owner’s operational needs.” The Maryland General Hospital case study (see Chapter 9) describes how the team used a building model, tablet PCs, and custom software to record equipment data and perform the commissioning activities.

**Quickly populate a facility management database**

In the Coast Guard Facility Planning case study, the team realized a 98 percent time savings by using building information models to populate and edit the facility management database. These savings are attributed to a reduction in labor needed to enter the spatial information.

**Manage facility assets with BIM asset management tools**

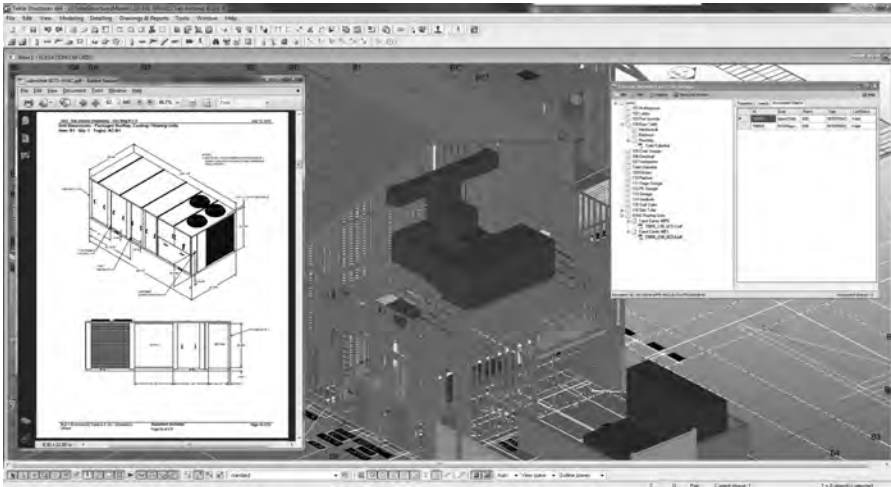
The United States Coast Guard is integrating BIM into its portfolio and asset management, as discussed in the Coast Guard Facility Planning case study. Blach Construction developed a BIM model for a school client to manage and maintain all of their MEP systems across their campuses (Figure 4–9). Another example is a 4D financial model shown in Figure 4–9.

Another example is a 4D financial model shown in Figure 4–10 that associates each building object or objects with a condition assessment over time. The owner can view the facility or facilities periodically to get a “big picture” view of its condition assessment.

**Rapidly evaluate the impact of retrofit or maintenance work on the facility**

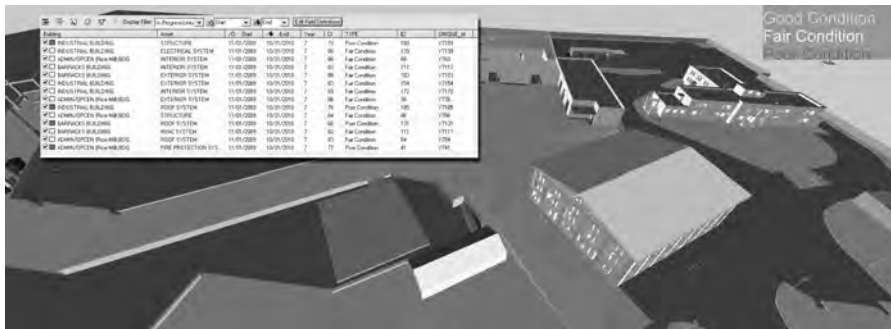
Another example is the use of visual and intelligent models to help facility managers assess the impact of retrofit or maintenance work. For example, a BIM-based FM system was applied during maintenance work on the Sydney Opera House (Mitchell and Schevers 2005). The maintenance team used the model to visually assess which areas would be affected when power was cut to a specific room.





**FIGURE 4-9** Example of using a building model to manage facility assets such as MEP systems. Blach Construction developed a model of the existing school to a “construction part” level—every stud, block, and bolt. The FM deliverable on the project included loading of the model with all submittal data for the MEP systems as well as linking of the 2D plan set to the model. The end user can quickly access documents such as maintenance manuals by simply selecting the desired piece of equipment in the model for which they need information. The documents open in their native format so they can be printed, emailed, or modified and saved back to the database.

Image provided courtesy of Blach Construction.



**FIGURE 4-10** A 4D financial model showing how the “assessed” condition of facilities, ranging from good (green) to fair to poor (red) as indicated by different colors, changes over time. (See color insert for full color figure.)

Image provided courtesy of PBS&J, Common Point, Inc., AEC Infosystems, Inc., and MACTEC, Inc.

## 4.3 BIM TOOL GUIDE FOR OWNERS

In the previous sections, we reference several BIM technologies that owners and their service providers are employing. In this section, we provide an overview of BIM tools or features of those tools intended to fulfill owners’ needs and other owner-specific BIM applications. Chapter 3 discussed model servers

and Chapters 5 through 7 discuss the specific BIM design and construction technologies, such as model generation tools, energy analysis, 4D, and design coordination. Here, the discussion addresses specific tools targeted to owners.

### 4.3.1 BIM Estimating Tools

Owners use estimates to baseline their project cost and perform financial forecasting or pro forma analyses. Often, these estimates are created early in design before the team develops a fully detailed building model. Estimates are created using square foot or unit cost methods, by an owner representative or estimating consultant. The Hillwood case study in Chapter 9 discusses the use of DProfiler to use the building model to generate conceptual and pro forma estimates.

Some estimating software packages, such as U.S. Cost Success Estimator (U.S. Cost 2010), are designed specifically for owners. Microsoft® Excel, however, is the software most commonly used for estimating. In 2007, U.S. Cost provided their customers with functionality to extract quantity takeoff information from a building model created in Autodesk Revit®. Another product targeted to owners is Exactal's CostX® product (Exactal 2010), which imports building models and allows users to perform automatic and manual takeoffs. Chapter 6 provides a more detailed overview of BIM-based estimating tools.

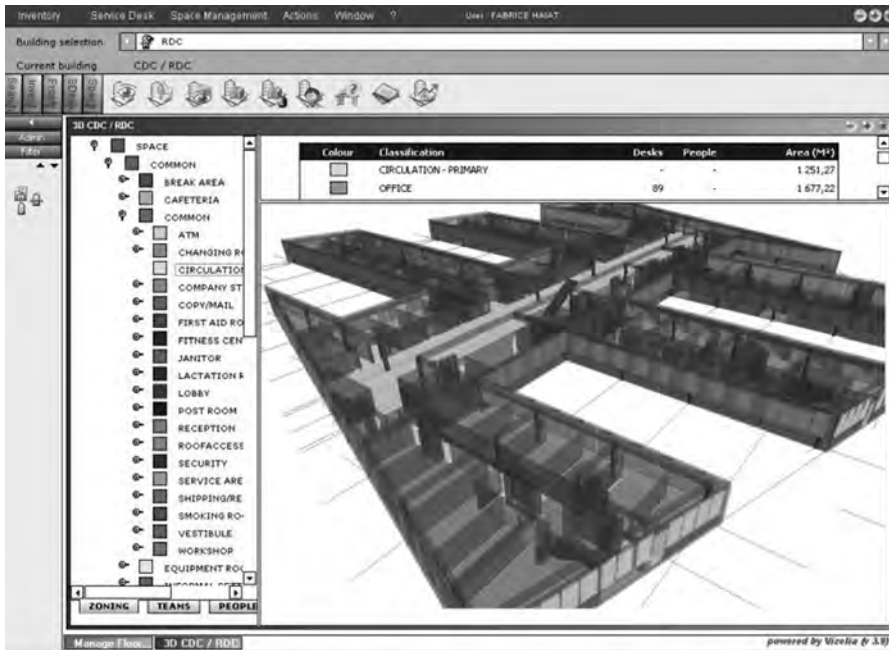
### 4.3.2 Facility and Asset Management Tools

Most existing facility management tools either rely on polygonal 2D information to represent spaces or numerical data entered in a spreadsheet. From most facility managers' perspectives, managing spaces and their related equipment and facility assets does not require 3D information; but 3D, component-based models can add value to facility management functions.

Building models provide significant benefits in the initial phase of entering facility information and interacting with that information. With BIM, owners can utilize "space" components that define space boundaries in 3D, thus greatly reducing the time needed to create the facility's database, since the traditional method involves manual space creation once the project is complete. The Coast Guard Facility Planning case study in Chapter 9 recorded a 98 percent reduction in time and effort to produce and update the facility management database by using a building information model.

Today, few tools exist that accept the input of BIM space components or other facility components representing fixed assets. Some of the tools that are currently available are:

- ActiveFacility ([www.activefacility.com](http://www.activefacility.com))
- ArchiFM ([www.graphisoft.co.uk/products/archifm/](http://www.graphisoft.co.uk/products/archifm/))



**FIGURE 4-11**  
Screenshot of Vizelia FACILITY Space showing the 3D, color-coded (shaded) view of spaces by type.

Image provided courtesy of Vizelia, Inc.

- ONUMA Planning System™ ([www.onuma.com](http://www.onuma.com))
- Vizelia suite of FACILITY management products ([www.vizelia.com](http://www.vizelia.com)) (see Figure 4-11)

In addition to the general features that any FM system should support, owners should consider the following issues with respect to the use of such tools with building models:

- **Space object support.** Does the tool import “space” objects from BIM authoring tools, either natively or via IFC? If so, what properties does the tool import?
- **Merging capabilities.** Can data be updated or merged from multiple sources? For example, MEP systems from one system and spaces from another system?
- **Updating.** If retrofit or reconfiguration of the facility takes place, can the system easily update the facility model? Can it track changes?
- **Sensor and control monitoring.** Are sensors and control systems part of the FM system? Can they be monitored and managed within the system?

Leveraging a building information model for facility management may require moving to specific BIM facility tools, or to third-party BIM add-on tools,

such as that demonstrated in the Maryland General Hospital case study. This project illustrates how the owner's maintenance team worked with the construction team to handover building model and use it to support commissioning and maintenance by integrating the BIM tool, Tekla Construction Management, with its Computerized Maintenance Management System (CMMS) tool.

One of the challenges with the handover from BIM to the CMMS is the standards and file formats common in BIM tools are not readily accepted by CMMS tools. One standard effort, COBie2 (see Chapter 3), is aimed to support the exchange of maintenance information.

The use of BIM to support facility management is in its infancy and the tools have only recently become available in the marketplace. Owners should work with their facility management organizations to identify whether current facility management tools can support BIM data or whether a transition plan to migrate to BIM-capable facility management tools is required.

### **4.3.3 Operation Simulation Tools**

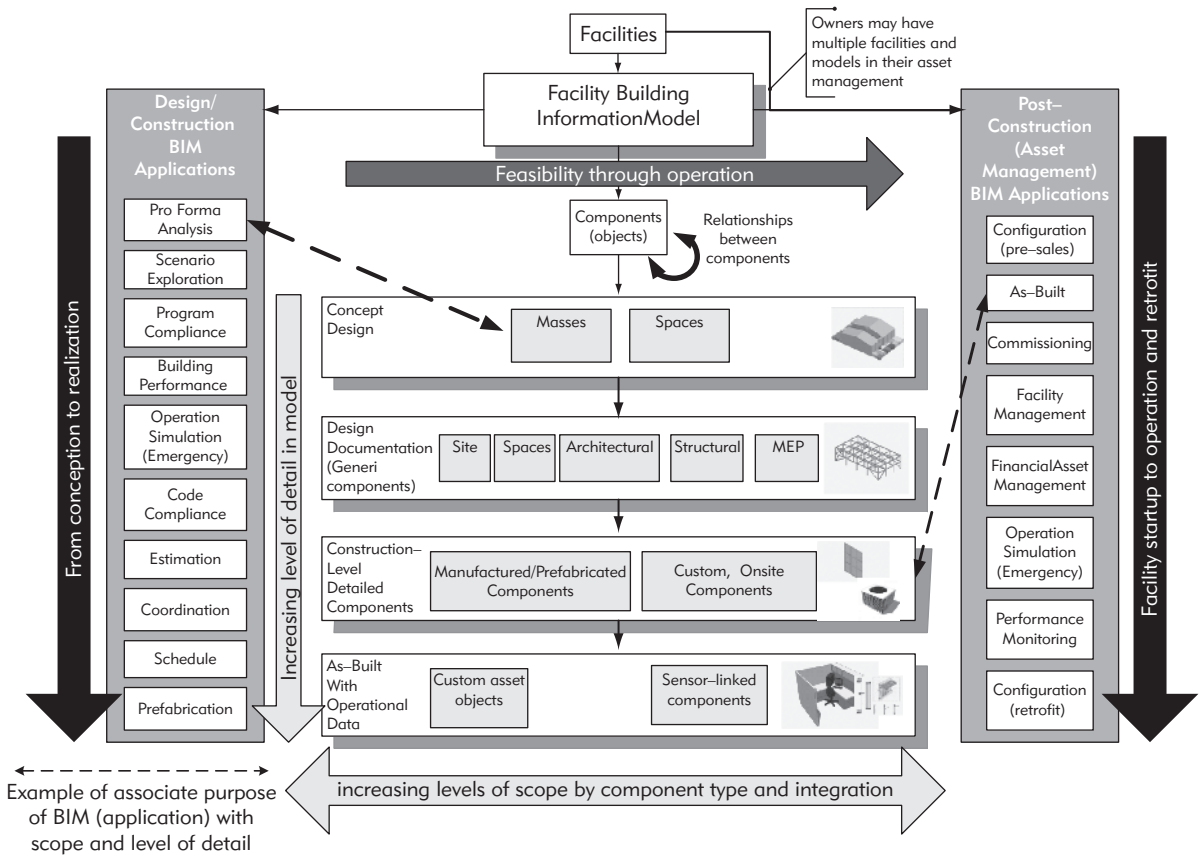
Operation simulation tools are another emerging category of software tools for owners that use data from a building information model. These include crowd behavior tools, such as Legion Studio, ViCrowd eRena, and Crowd Behavior; hospital procedure simulation, and emergency evacuation or response simulations, such as IES Simulex or building Exodus. Many of them are provided by firms that also offer the services to perform the simulations and add necessary information. In all cases, the tools require additional input of information to perform the simulations; and in some cases, they only extract the geometric properties from the building information model.

More typical examples of operation simulation tools do not involve specialized simulations but the use of real-time visualization or rendering tools that take the building information model as input. For example, one author participated in the development of a 3D/4D model for Disney California Adventure. With specialized tools and services, the same model was used to simulate emergency scenarios for the rollercoaster ride (Schwegler et al. 2000). Likewise, the Letterman Lucas Digital Arts center team used their model to evaluate evacuation and emergency response scenarios (Boryslawski 2006; Sullivan 2007).

---

## **4.4 AN OWNER AND FACILITY MANAGER'S BUILDING MODEL**

Owners need not only be conversant in the kinds of BIM tools available but also understand the scope and level of detail they desire for a building model



**FIGURE 4-12** Conceptual diagram showing the relationship between various BIM applications during the facility delivery process; postconstruction and their relationship to the level of scope and detail in the model.

of their project. In Chapters 5, 6, and 7, we discuss the types of information that designers, engineers, contractors, and fabricators create and add to building information models to support many of the BIM applications. To take advantage of post-construction BIM applications, as discussed in Section 4.2 and listed in Figure 4-12, owners need to work closely with their service providers to ensure that the building model provides adequate scope, level of detail, and information for the purposes intended. Figure 4-12 provides a framework for owners to understand the relationship between the level of detail in a model—masses, spaces, and construction-level detail (see vertical direction)—and the scope of a model, including spatial and domain-specific elements such as architectural and detailed MEP elements.

Often, each service provider defines the scope and level of detail required for their work. The owner can mandate the scope and level of detail required for

**Table 4–2** Owner’s Building Information Model

Purpose	Type of Model Information
To support program compliance and facility management. In a typical design process, the spatial information is defined to meet program compliance and support code-checking analysis. These are critical for program compliance and use of the BIM for facility management.	Spaces and functions
To support commissioning activities such as performance specifications	Performance specifications for HVAC and other facility operation equipment
For postconstruction analysis and tracking as well as data for future forecasting	As-built schedule and cost information
To budget and schedule maintenance	Manufactured product information
For replacement costs and time periods and assessment information (See Coast Guard Facility Planning case study)	Financial asset management data
To plan and prepare for evacuation and other emergency crises	Emergency information
To monitor and track progress of design, construction, or maintenance activities	Activity status
To monitor building sensors and real-time control of building systems	Sensor data

post-construction use of the model. For example, at the feasibility stage, masses and spaces are sufficient to support most BIM applications for conceptual design. If the owner requires more integrative BIM applications, then both the level of integration in the model (horizontal) and level of detail (vertical) are increased in the effort to produce the model.

Table 4–2 provides a partial list of some key types of information that the building model needs to support for post-construction use. Some of this information is represented in the IFC schema, as discussed in Chapter 3, and there is a working group within the IAI, the “Facility Management Domain” ([www.buildingsmart.com/content/fm\\_handover\\_view\\_aquarium](http://www.buildingsmart.com/content/fm_handover_view_aquarium)) that addresses facility-specific scenarios, such as move management, work order flows, costs, accounts, and financial elements in facility management. The IAI focuses on the representation of this information within the building model.

Other resources for owners with respect to understanding and defining building information requirements are:

- **OSCRE**® (Open Standards Consortium for Real Estate, [www.oscre.org](http://www.oscre.org)). This nonprofit organization is defining information requirements

and standards for transaction-based scenarios, including appraisal, commercial property information exchange, and facilities management work orders.

- **Capital Facilities Information Handover Guide** (NIST and FIATECH 2006). This document defines information handover guidelines for each phase of facility delivery and the building's lifecycle and elaborates many of the information issues discussed in this section.
- **OGC** (Open Geospatial Consortium, [www.opengeospatial.org](http://www.opengeospatial.org)). This nonprofit standards organization is developing standards for geospatial data and has a specific working group looking at the integration of GIS and building model data.

COBie2 (Construction Operations Building Information Exchange, [www.wbdg.org/resources/cobie.php](http://www.wbdg.org/resources/cobie.php)). COBie2 simplifies the work required to capture and record project handover data. The COBie2 approach is to enter the data as it is created during design, construction, and commissioning. Designers provide floor, space, and equipment layouts. Contractors provide make, model, and serial numbers of installed equipment. Much of the data provided by contractors comes directly from product manufacturers who can also participate in COBie2 (<http://www.wbdg.org/resources/cobie.php>).

---

## 4.5 LEADING THE BIM IMPLEMENTATION ON A PROJECT

Owners control the selection of design service providers, the type of procurement and delivery processes, and the overall specifications and requirements of a facility. Unfortunately, many owners accept the current status quo and may not perceive their ability to change or control how a building is delivered. They may even be unaware of the benefits that can be derived from a BIM process.

Owners cite challenges with changing standard design or construction contracts produced by governing associations such as the American Institute of Architects (AIA) or the Association of General Contractors (AGC). The federal government, for example, faces many barriers to changing contracts since these are governed by agencies and legislatures. These challenges are real and the AIA, AGC, and federal agencies such as the GSA and Army Corps of Engineers are working toward instituting the contracting methods necessary to support more collaborative and integrated methods of procurement

(see Chapters 5 and 6 for a discussion of these efforts). Yet, the case studies and the various projects cited in this book demonstrate a variety of ways in which owners can work within current contractual arrangements and overcome the barriers presented in Section 4.6. Owner leadership and involvement is a prerequisite for optimal use of BIM on a project.

Owners can deliver maximum value to their organization by reviewing and developing BIM guidelines, building internal leadership and knowledge, by selecting service providers with BIM project experience and know-how, and by educating the network of service providers and changing contractual requirements.

#### **4.5.1 Develop Guidelines for BIM on Projects**

Many organizations, particularly owners that build and manage multiple facilities, have developed guidelines for BIM. These include government agencies, such as the GSA, Coast Guard, U.S. Army Corps of Engineers, and State of Texas and Wisconsin, and schools, such as Los Angeles Community College District (LACCD), and Indiana University. The real estate owners, Senate Properties, have its BIM Guidelines which contain the following key components:

- Identification of goals for BIM use and its alignment with organizational goals
- Scope and use of BIM across phases of project (for example, a checklist of BIM applications, such as use of BIM for energy analysis or clash detection)
- Scope of standards or formats related to BIM and the exchange of BIM
- Roles of participants in the BIM process and handovers between all participants

Owners should review these guidelines as a starting point and over time develop guidelines that fit their project goals.

#### **4.5.2 Build Internal Leadership and Knowledge**

The owner-led BIM efforts in presented in Chapter 9 (Sutter Medical Center; One Island East Office Tower; and Coast Guard Facility Planning) share two key processes: (1) the owner first developed internal knowledge about BIM technologies; and (2) the owner dedicated key personnel to lead the effort. For example, in the Sutter Medical Center project, the owner examined internal work processes intensively and identified the tools and lean methods that



could deliver the facilities more efficiently. On these projects, the owners did not develop the full knowledge of how to implement various BIM applications but created a project environment where service providers could constructively apply appropriate BIM applications.

The One Island East Office Tower case study shows a slightly different approach to building that knowledge. The owner, Swire Properties Inc., had done extensive research to improve the company's ability to better deliver and manage their facilities and properties. They identified barriers related to the management of 2D information and the wide variety of project information. When they were presented with the concepts of building information modeling, they had the internal knowledge to know where to apply and leverage available BIM technologies.

The U.S. Coast Guard is building its internal knowledge and defining a roadmap for implementing BIM, as discussed in the Coast Guard Facility Planning case study (Brucker et al. 2006). This roadmap is a phased approach to implementing BIM across their organization and various facility projects. The knowledge necessary to build such a roadmap was the result of pilot projects and a significant investigation and research effort led by various groups within the U.S. Coast Guard. The roadmap includes both milestones related to specific BIM technology applications for managing project information and facility assets as well as milestones for procuring and delivering facilities using various BIM applications.

All of these cases demonstrate owners that developed knowledge through an exploration of their own internal business models and work processes related to delivering and operating facilities. They understood the inefficiencies inherent in their current work processes and how they impacted the bottom line. In so doing, key members of the staff were equipped with the knowledge and skills to lead the BIM effort.

### 4.5.3 Service Provider Selection

Unlike the case in global manufacturing industries, such as that of automobiles or semiconductors, no single owner organization dominates the building market. Even the largest owner organizations, which are typically government agencies, represent only a small fraction of the overall domestic and global facility markets. Consequently, efforts to standardize processes, technologies, and industry standards are far more challenging within the AEC industry than in industries with clear market leaders. With no market leaders, owners often look at what their competition is doing or to industry organizations as guides for best practice or latest technology trends. In addition, many owners build or

initiate only one project and lack expertise to take a leadership position. What all owners share, though, is the control over how they select service providers and the format of project deliverables.

Owners can use a number of methods to ensure that the service providers working on their project are conversant in BIM and its related processes:

### **Modifying job skill requirements to include BIM-related skills and expertise**

For internal hires, owners can require prospective employees to have specific skills, such as 3D and knowledge of BIM or component-based design. Many organizations are now hiring employees with BIM-specific job titles such as *BIM Specialist*, *BIM Champion*, *BIM Administrator*, *4D Specialist*, and *Manager, Virtual Design and Construction*. Owners may hire employees with these titles or find service providers that bear similar ones. Some examples of job skill requirements are detailed in the box titled “Examples of Job Skill Requirements” (J.E. Dunn 2007).

### **Including BIM-specific prequalification criteria**

Many Requests for Proposals (RFPs) by owners include a set of prequalification criteria for prospective bidders. For public works projects, these are typically standard forms that all potential bidders must fill out. Commercial owners can formulate their own prequalification criteria. An excellent example is the qualification requirements formulated by hospital owner Sutter Health that are described in the Medical Building case study in Chapter 9. These include explicit requirements for experience and the ability to use 3D modeling technologies.

### **Interviewing prospective service providers**

Owners should take the time to meet designers face-to-face in the prequalification process, since any potential service provider can fill out a qualification form and note experience with specific tools without having project experience. One owner even prefers meeting at the designer’s office to see the work environment and the types of tools and processes available in the workplace. The interview might include the following types of questions:

- What BIM technologies does your organization use and how did you use them on previous projects? (Perhaps use a modified list of BIM application areas from Table 4–1 as a guide.)
- What organizations collaborated with you in the creation, modification, and updating of the building model? (If the question is asked to an architect, then find out if the structural engineer, contractor, or

## Examples of Job Skill Requirements

- Minimum three to four years' experience in the design and/or construction of commercial buildings structures
- B.S. Degree (or equivalent) in construction management, engineering, or architecture
- Demonstrated knowledge of building information modeling
- Demonstrated proficiency in one of the major BIM applications and familiarity with review tools
- Working knowledge and proficiency with any of the following: Revit, ArchiCAD, Navisworks, SketchUp, Autodesk® Architectural Desktop, and Building Systems (or other specific BIM applications that your organization uses)
- Solid understanding of the design, documentation, and construction processes and the ability to communicate with field personnel

prefabricator contributed to the model and how the different organizations worked together.)

- What were the lessons learned and metrics measured on these projects with respect to the use of the model and BIM tools? And how were these incorporated into your organization? (This helps to identify evidence of learning and change within an organization.)
- How many people are familiar with BIM tools in your organization and how do you educate and train your staff?
- Does your organization have specific job titles and functions related to BIM (such as those listed previously)? (This indicates a clear commitment and recognition of the use of BIM in their organization.)
- How will you turn over the BIM model(s) used on this project and how can I transfer the information needed for my facility management system?

### 4.5.4 Build and Educate a Qualified Network of BIM Service Providers

One of the challenges for owners is finding service providers proficient with BIM technologies within their existing network. This has led several owners to lead proactive efforts to educate potential service providers, internal and

external, through workshops, conferences, seminars, and guides. Here are three examples:

**Formal education.** The United States General Services Administration has established a National 3D/4D BIM Program (General Services Administration 2006). Part of this effort includes educating the public and potential service providers and changing how they procure work (see Section 4.5.5). The educational efforts include working with BIM vendors, professional associations such as the AIA and AGC, as well as standards organizations and universities, by sponsoring seminars and workshops. Each of the ten GSA regions has a designated BIM “champion” to push adoption and application to projects in their respective regions. For example, the authors have each been invited to present BIM concepts to various owners’ groups, both in the United States and other parts of the world. Unlike some commercial organizations, the GSA does not view its BIM expertise and knowledge as proprietary and recognizes that for the GSA to ultimately benefit from the potential of BIM, all project participants need to be conversant with BIM technologies and processes.

**Informal education.** Sutter Health’s educational efforts are largely centered around implementing lean processes and BIM technologies on their projects. Sutter invited service providers to attend informal workshops with presentations on lean concepts, 3D, and 4D. Sutter also supports project teams using BIM technologies to conduct similar workshops open to industry professionals. These informal workshops provide ways for professionals to share experiences and learn from others and ultimately to widen the number of service providers available to bid on future Sutter projects.

**Training support.** A critical part of education, beyond teaching BIM concepts and applications, is related to technical training for specific BIM tools. This often requires both technical education of BIM concepts and features for transitioning from 2D- to 3D-component parametric modeling as well as software training to learn the specific features of the BIM tools. For many service providers, the transition is costly, and it is difficult to justify initial training costs. Swire Properties (see One Island East Office Tower case study in Chapter 9) recognized this as a potential barrier and paid for the training of the design team to use specific BIM tools on their project.

#### 4.5.5 Change Deliverable Requirements: Modify Contracts and Contract Language

Owners can control which BIM applications are implemented on their projects through the type of project delivery process they select and with BIM-specific

contractual or RFP requirements. Changing the delivery process is often more difficult than changing the requirements. Many owners first start with changes in the RFP and contracts in three areas:

### **1. Scope and detail of the model information**

This includes defining the format of project documentation and changing from 2D paper to a 3D digital model. Owners may choose to forego specific requirements pertaining to the 3D format and the types of information service providers include in the model (see Figure 4–12 and Section 4.4); or owners can provide detailed language for those requirements (see the Sutter Medical Center case study in Chapter 9). As owners gain experience, the nature of these requirements will better reflect the types of BIM applications an owner desires and the information that the owner team demands throughout the delivery process and subsequent operation of the facility. Table 4–3 provides a reference for the types of information an owner should consider relative to desired BIM applications.

### **2. Uses of model information**

This includes specifying services more readily performed with BIM tools, such as 3D coordination, real-time review of design, frequent value engineering using cost estimating software, or energy analysis. All of these services could be performed with traditional 2D and 3D technologies; but providers using BIM tools would most likely be more competitive and capable of providing such services. For example, 3D coordination is greatly facilitated through BIM tools. Tables 4–1, 4–2, and 4–3 provide a summary of the BIM applications owners can use as a basis to describe the services relevant to their specific projects.

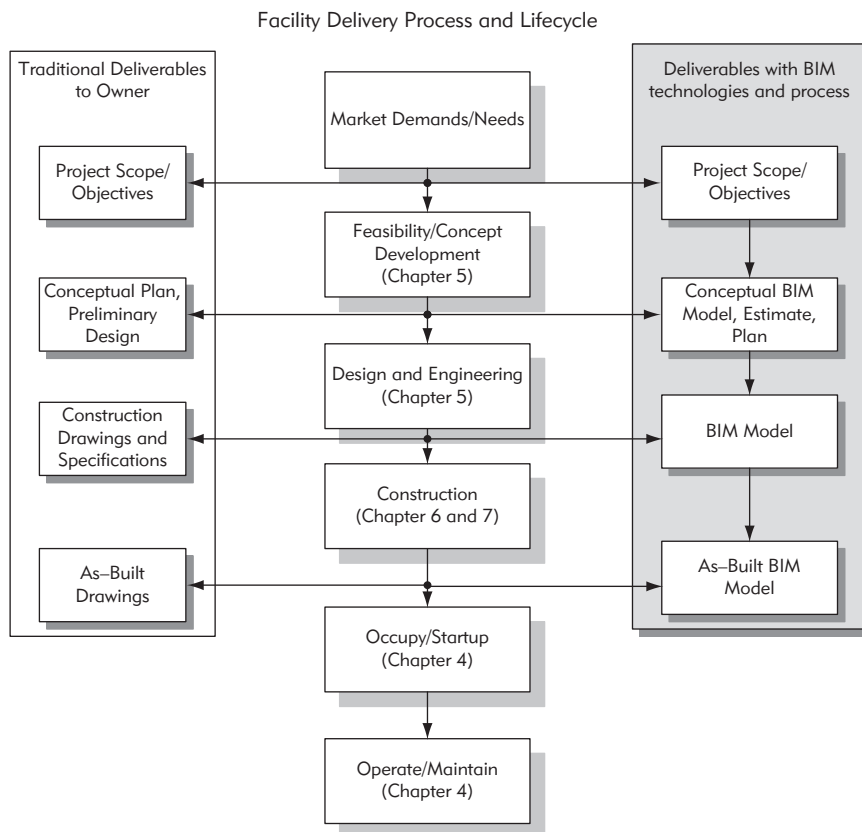
### **3. Organization of model information.**

This includes project work breakdown structure and is discussed in Section 4.3.1. Many owners overlook this type of requirement. Today, CAD layer standards or Primavera activity fields are templates for how designers organize the project documentation and the building information. Similarly, owners or the project team need to establish an initial information organization structure. This may be based on the geometry of the project site (Northeast section) or the building structure (East wing, Building X). The One Island East case study discusses the project work breakdown structure that the teams employed to facilitate the exchange of building BIM and project documentation. Efforts are underway to establish building model standards, such as the National Building Information Model Standard. This standard should provide much-needed definition



and a useful resource for owners to define the project work breakdown structure. The U.S. Coast Guard, for example, references these within their milestones.

These requirements, however, are often difficult to meet without some modifications to the fee structure and relationships between project participants or without the use of incentive plans that define the workflow and digital hand-offs between disciplines. Often, these are more difficult to define in a workflow centered on a digital model, as opposed to files and documents. Additionally, approval agencies still require 2D project documentation as do a majority of professional contracts. Consequently, many owners maintain the traditional document and file-based deliverables (see Figure 4–13); and they insert digital 3D workflows and deliverables into the same process. That is, each discipline works independently on their scope and BIM applications and hands-off the 3D digital model at specified times. Clearly, this is not a desirable approach to using BIM to its maximum advantage.



**FIGURE 4–13**

Typical contract deliverables resulting from the traditional design-bid-build process as compared to the types of deliverables that result from a collaborative BIM-based process such as IPD.

Owners will need to change contracts and language to promote the use of BIM.

**Modified design-build delivery.** The GM Production Plant project (see Section 9.1 of the first edition of the *BIM Handbook*) demonstrates a collaborative process achieved through modifications to the design-build delivery process. GM hired the design-build team and then participated in the selection of subcontractors and additional design consultants. The goal was to form the team as early as possible and engage them from the outset.

**Performance-based contracts.** Performance-based contracts or performance-based acquisition (PBA) focus on results, are typically fixed-fee, and allow service providers to deliver a facility or their services using their own best practices (Department of Defense 2000). This emphasizes the outcome, as defined by the owner, rather than intermediate milestones or deliverables. Many government agencies are moving to this approach, targeting 40 to 50 percent of new work using this approach (General Services Administration 2007). This type of contract typically requires that the owner spend more time early in the project to define the facility requirements and structure the contracts to accommodate such an approach. This approach may seem a contradiction to the previous recommendations; but service providers utilizing BIM will most likely be more competitive and requirements can be BIM-based.

**Shared incentive plans.** Performance-based contracts are often implemented with shared incentive plans. When all members collaborate on most phases of building, there is no clear partitioning of organization contributions. This is the intent of IPD arrangements, introduced in Section 4.1. The Sutter Medical Center case study in Chapter 9 provides an example of a shared incentive plan designed to distribute cost savings to the project team. It provides financial incentives based on the overall project performance and not solely on individual organizational performance. These plans are often difficult to define and implement, as the case study demonstrates. Nonetheless, shared incentive plans reward teams for collaborative performance rather than local optimization of discipline-specific performance.

These different procurement methods do not address situations where owners perform some or all of the design, engineering, or construction services. Outsourcing is a common trend for many owners (Geertsema et al. 2003). There are some owner organizations that have construction management and construction superintendents on staff. In such cases, as discussed in Section 4.7, the owner must first assess their internal capabilities and work processes. The “wall” of deliverables can exist internally, and defining model handover requirements between internal groups is just as critical. The owner must ensure that



all participants, internal or external, can contribute to the creation, modification, and review of the building model. This may involve the owner requiring the use of specific software or data formats to exchange data.

Outsourcing, however, does have an impact on the overall BIM effort, and owners who choose to hire a third party to produce the building information model independent of the project's internal and external team of service providers should carefully consider full outsourcing of the model. Typically, the outsourcing effort leads to a building information model that is underutilized, outdated, and of poor quality. This occurs for several reasons. First, the internal or external team has to reach a specified point in the project to hand over the traditional documentation. Second, the outsource team must spend significant time, often with little contact since the team is now busy working toward the next deliverable, to understand and model the project. Finally, the outsource team does not typically have highly skilled or experienced staff with building knowledge. Thus, outsourcing should be done with considerable attention and management oversight or be used as an effort to support the BIM effort, not replace it. The One Island East Office Tower case study is an excellent example of working with external resources to develop the building model while integrating its resources into the project team both physically and virtually. Another example is the Letterman Digital Arts project in San Francisco, where the owner hired an outside firm to build and maintain the building model (Sullivan 2007). In both cases, the critical success factor was attributed to bringing the resources onsite and mandating participation by all project participants.

---

## 4.6 BARRIERS TO IMPLEMENTING BIM: RISKS AND COMMON MYTHS

There are risks associated with any changes to work processes. Realistic and perceived barriers and changes related to implementing BIM applications on projects are no exception. These barriers fall into two categories: process barriers to the business, including legal and organizational issues that prevent BIM implementation; and technology barriers related to readiness and implementation. These are summarized below.

### 4.6.1 Process Barriers

**The market is not ready—it's still in the innovator phase.** Many owners believe that if they change the contracts to require new types of deliverables, specifically 3D or building information models, they will not receive competitive bids, limiting their potential pool of bidders and ultimately increasing the price

of the project. Recent surveys, however, do indicate that a majority of service providers are using BIM technologies (to various extents) on their projects. The degree of adoption varies from just using BIM to generate drawings to full participation in IPD teams.

- **Adoption among architects, engineers, and contractors has moved well beyond the “early adopters” stage.** By 2009, more than 50 percent of each of these groups reported using BIM at moderate levels or higher (Young et al. 2009). In 2007, only 34 percent of architects claimed they used 3D/BIM tools for “intelligent modeling” (i.e., not simply for the generation of 2D drawings and visualizations) (Gonchar 2007). In 2000, the use of intelligent modeling was rare.
- Adoption of BIM by regulatory agencies for review of proposed new buildings or modifications to existing buildings is negligible in the United States, but there is some progress in other countries e.g., CORENET, 2010.

The case studies in this book, and many of its bibliographical references, indicate a transition from innovator to early adopter phase for design-related BIM applications. As the use of BIM increases, owners will find increasing numbers of service providers capable of using BIM.

### ***The Project Is Already Financed and Design Is Complete—It’s Not Worth It to Implement BIM***

As a project nears construction, it’s true that owners and the project team will miss valuable opportunities available through the use of BIM applications, such as conceptual estimating and program compliance. There is still ample time and opportunity, however, to implement BIM in the latter stages of design and through the early phases of construction. For example, the BIM implementation in the One Island East Office Tower case study began after construction documents were started. The BIM implementation on the Letterman Digital Arts Center, driven by the owner, began postdesign and resulted in significant identification of design discrepancies and estimated cost savings of \$10 million (Boryslawski 2006). The team, however, recognized that had the effort started earlier even more cost savings and benefits would have been realized.

### ***Training Costs and the Learning Curve Are Too High***

Implementing new technologies such as BIM technologies is costly in terms of training and changing work processes and workflows. The dollar investment in software and hardware is typically exceeded by the training costs and initial

productivity losses. This can be seen clearly in the adoption cash flow example in Chapter 7. Often, most service providers are not willing to make such an investment unless they perceive the long-term benefit to their own organization and/or if the owner subsidizes the training costs. In the One Island East Office Tower case study, the owner understood that the potential gains in productivity, quality, and asset management outweighed the initial costs and paid for the training.

#### ***Everyone Must Be on Board to Make the BIM Effort Worthwhile***

It is often difficult to ensure that all project participants have the know-how and willingness to participate in the creation or use of the building information model. Many of the case studies in Chapter 9 demonstrate the benefits of BIM implementation without full participation but also highlight challenges with recreating information from organizations not participating in the modeling effort.

#### ***Too Many Legal Barriers Exist and They Are Too Costly to Overcome***

Contractual and legal changes are required on several fronts to facilitate the use of BIM and more collaborative project teams. Even the digital exchange of project information is sometimes difficult today, and teams are often forced to exchange only paper drawings and rely on old-fashioned contracts. Public institutions face even greater challenges, since they are often governed by laws that take considerable time to change. Nonetheless, several government agencies and private companies have overcome these barriers and are working toward contract language that not only changes the nature of how information is exchanged within the project team but the liability and risks associated with a more collaborative effort. The Sutter Medical Center is an example of this.

The primary challenge is the assignment of responsibility and risk. BIM implementation centralizes information that is “broadly accessible,” depends on constant updating, and subjects designers to increased potential liability (Ashcraft 2006). The legal profession recognizes these barriers and the necessary risk-allocation changes that need to take place. This is a real barrier, one that will continue to persist and will depend on professional organizations such as the AIA and AGC to revise standard contracts and/or owners to revise their own contract terms.

#### ***Issues of Model Ownership and Management Will Be Too Demanding on Owner Resources***

BIM potentially requires insight across multiple organizations and aspects of the project. Typically, a construction manager (CM) provides the oversight by managing communication and reviewing project documentation. The CM also

oversees that the process is aligned with specific deliverables and milestones. With BIM, issue discovery and problem identification occur early and more frequently, enabling teams to resolve issues early; but this often requires owner input, which should be seen as a benefit and not a drawback. The current slack in the delivery process is significantly reduced, demanding more direct owner involvement. The process is more fluid and interactive. Owner-requested changes will become less transparent and the impacts of these changes will demand ongoing participation. Managing this process and the related management of the model will become critical to the project. Owners need to establish clear roles and responsibilities and methods to communicate with the project team and ensure that an owner representative is available as needed.

#### **4.6.2 Technology Risks and Barriers Technology Is Ready for Single-Discipline Design but Not Integrated Design**

It is true that two to five years ago the creation of an integrated model required extensive effort on the part of a project team and dedicated technical expertise to support that integration. Today, many of the BIM design tools reviewed in Chapter 2 have matured and provide integration capabilities between several disciplines at the generic object level (see Figure 4–13). As the scope of the model and number and types of building components increase, however, performance issues also increase. Thus, most project teams choose to use model review tools to support integration tasks, such as coordination, schedule simulation, and operation simulation. The Castro Valley Medical Center and the Crusell Bridge projects, for example, used the Navisworks model review tool to perform clash detection and design coordination. Currently, BIM design environments are typically good for one- or two-discipline integration. The integration of construction-level detail is more difficult, and model review tools are the best solution to achieve this.

A greater barrier is related to work process and model management. Integrating multiple disciplines requires multiuser access to the building information model. This does require technical expertise, establishment of protocols to manage updates and edits of the model, and establishing a network and server to store and access the model. It also provides an excellent context for new users to learn from more experienced ones.

Owners should perform audits with their project teams to determine the type of integration and analysis capabilities that are desired and currently available and prioritize accordingly. Full integration is possible but does require expertise, planning, and proper selection of BIM tools.

### ***Standards Are Not Yet Defined or Widely Adopted—So We Should Wait***

Chapter 3 discusses the various standards efforts, such as IFCs and the National BIM Standards, which will greatly enhance interoperability and widespread BIM implementation. The Crusell Bridge and Helsinki Music Hall case studies (Chapter 9), both in Finland, illustrate the effective use of IFC-based model exchange. Although software companies have improved their IFC import and export functions, designers have not yet learned to make optimal use of the exchange standards, and many organizations use proprietary formats for model exchange. For owners, this may pose a risk to the short- and long term-investments in any building information modeling effort. There are owner-specific standardization efforts related to real estate transactions and facility management, as discussed previously; however, the case studies in this book demonstrate that a variety of successful BIM implementations have been achieved without reliance on these standards; and it is not a barrier to implementation.

---

## **4.7 GUIDELINES AND ISSUES FOR OWNERS TO CONSIDER WHEN ADOPTING BIM**

Adopting BIM alone will not necessarily lead to project success. BIM is a set of technologies and evolving work processes that must be supported by the team, the management, and a cooperative owner. BIM will not replace excellent management, a good project team, or a respectful work culture. Here are some key factors an owner should consider when adopting BIM.

### **Perform a pilot project with a short time frame, small qualified team, and a clear goal**

The initial effort should use either internal resources or trusted service providers that your organization has worked with. The more knowledge an owner builds with respect to the implementation and application of BIM, the more likely future efforts will succeed, as the owner develops core competencies to identify and select qualified service providers and forge cooperative teams.

### **Do a prototype dry run**

When doing a pilot project, it's always best to do a dry run and make sure the tools and processes are in place to succeed. This may be as simple as giving the designer a small design task that showcases the desired BIM applications. For example, the owner can ask the design team to design a conference room for twenty people, with specific targets for budget and

energy consumption. The deliverable should include a building information model (or models to reflect two or three options) and the related energy and cost analyses. This is an example of a design task that is achievable in one or two days. The architect can build the model and work with an MEP engineer and estimator to produce a set of prototype results. This requires that the project participants work out the kinks in the process, so to speak, and also allows the owner to provide guidance regarding the types of information and formats of presentation that provide clear, valuable, and rapid feedback.

### **Focus on clear business goals**

While this chapter cites many different benefits, no single project has yet achieved all of these benefits. In many cases, the owner started with a specific problem or goal and succeeded. The GSA's pilot project efforts (Dakan 2006), for example, each involved one type of BIM application for nine different projects. The application areas included energy analysis, space planning, laser scanning to collect accurate as-built data, and 4D simulation. The success in meeting focused and manageable goals led to expanded use of multiple BIM applications on projects such as the evolving use of BIM on the Crusell Bridge case study in Chapter 9.

### **Establish metrics to assess progress**

Metrics are critical to assessing the implementation of new processes and technologies. Many of the case studies include project metrics, such as reduced change orders or rework, variance from baseline schedule or baseline cost, and reduction in typical square footage cost. There are several excellent sources for metrics or goals relevant to specific owner organizations or projects, including:

- **Construction Users Roundtable (CURT)**. This owner-led group holds workshops and conferences and issues several publications on their Web site ([www.curt.org](http://www.curt.org)) for identifying key project and performance metrics.
- **CIFE Working Paper on Virtual Design and Construction** (Kunz and Fischer, 2007). This paper documents specific types of metrics and goals along with case study examples.

Also, see Section 5.5.1 for the development of assessment metrics related to design.

### **Participate in the BIM effort**

An owner's participation is a key factor of project success, because the owner is in the best position to lead a project team to collaborate in ways that exploit BIM to its fullest benefit. All of the case studies in which

owners took leadership roles demonstrate the value of the owner's participation in proactively leading the BIM implementation. They also highlight the benefits of ongoing involvement in that process. BIM applications, such as those for BIM design review, enable owners to better participate and more easily provide the necessary feedback. The participation and leadership of owners is critical to the success of the collaborative project teams that exploit BIM.

---

## Chapter 4 Discussion Questions

---

1. List three types of procurement methods and how these methods do or do not support the use of BIM technologies and processes.
2. Imagine you are an owner embarking on a new project and have attended several workshops discussing the benefits of BIM. What issues would you consider when deciding whether you should support and promote the use of BIM on your project?
3. If the owner did decide to adopt BIM, what types of decisions would be needed to ensure the project team's success in using BIM at each stage of the building lifecycle?
4. With respect to the application and benefits of BIM technologies and processes, what are the key differences between an owner who builds to sell a facility versus an owner who builds to operate?
5. Imagine you are an owner developing a contract to procure a project using a collaborative approach through the use of BIM. What are some of the key provisions that the contract should include to promote team collaboration, the use of BIM, and project success?
6. List and discuss three risks associated with using BIM and how they can be mitigated.
7. List two or three processes or project factors that influence the success of BIM implementation.
8. Imagine you are an owner building your first project and plan to own and occupy the facility for the next 15 to 20

years. You do not plan to build another facility and will outsource its design and construction. Should you consider BIM? If so, list two or three reasons why BIM would benefit your organization, and describe what steps you might take to achieve the benefits you cite. If you believe that BIM would not benefit your project, explain why.

9. List three market trends that are influencing the adoption and use of BIM and how BIM enables owners to respond to those market trends.



# CHAPTER 5

---

## BIM for Architects and Engineers

---

### 5.0 EXECUTIVE SUMMARY

Building Information Modeling (BIM) can be considered an epochal transition in design practice. Unlike CADD, which primarily automates aspects of traditional drawing production, BIM is a paradigm change. By partially automating the detailing of construction-level building models, BIM redistributes the allocation of effort, placing more emphasis on conceptual design. Other direct benefits include easy methods guaranteeing consistency across all drawings and reports, automating spatial interference checking, providing a strong base for interfacing analysis/simulation/cost applications and enhancing visualization/communication at all scales and phases of the project.

This chapter examines the impact of BIM on design from three viewpoints:

- *Conceptual design* addresses the conceptual and spatial organization of the project and determines its parti. BIM potentially makes easier generation of complex building shells and potentially supports more thorough

exploration and assessment of preliminary design, but the workflows to support this are only partially in place.

- *The integration of engineering services.* BIM supports new information workflows and integrates them more closely with existing simulation and analysis tools used by consultants.
- *Construction-level modeling* includes detailing, specifications, and cost estimation. This is the base strength of BIM. This phase also addresses what potentially can be achieved through a collaborative *design-construction process*, such as with design-build and Integrated Project Delivery (IPD).

The contractual provisions under which design services are offered are changing. New arrangements, such as design-build and IPD, affect communication and collaboration, altering the processes of design. Different design projects can be categorized according to the level of information development required for realizing them, ranging from predictable franchise-type buildings to experimental architecture. The information development concept facilitates distinguishing the varied processes and tools required for designing and constructing all varieties of buildings.

This chapter also addresses issues of adoption of BIM into practice, such as: the evolutionary steps to replace 2D drawings with 3D digital models; automated drawing and document preparation; managing the level of detail within building models; the development and management of libraries of components and assemblies; and new means for integrating specifications and cost estimation. The chapter concludes with a review of the practical concerns that design firms face when attempting to implement BIM, including: the selection and evaluation of BIM authoring tools; training; office preparation; initiating a BIM project; and planning ahead for the new roles and services that a BIM-based design firm will evolve toward.

---

## 5.1 INTRODUCTION

In 1452, Renaissance architect Leon Battista Alberti in his *De re aedificatoria* (1987, *The Ten Books of Architecture*) distinguished architectural “design” from “construction” by proposing that the essence of design lay in the thought processes associated with conveying lines on paper. His goal was to differentiate the intellectual task of design from the craft of construction. Prior to Alberti, in the first century BC, Vitruvius, in his *Ten Books of Architecture*, discussed the value inherent in using plans, elevations, and perspectives to

convey design intent. Throughout architectural history, drawing has been the dominant mode of representation and fundamental to its self-identification. Even now, contemporary writers critique how different architects use drawings and sketches to enhance their thinking and creative work (Robbins 1994). The extent of this time-honored tradition is further apparent in the way that computers were first adopted in architecture, as CADD—computer-aided design and drafting.

Because of this history, building information modeling is revolutionary in the way it transforms architectural representation by replacing drawings with 3D virtual building models. It changes the way that a representation is constructed, fundamentally changing the line-by-line layout of old and the thought processes that go with it. Learning the tools of BIM is just the first-level step, leading to how design concepts are generated, refined, and evaluated. These changes suggest major rethinking regarding the degree that designs are generated conceptually in a designer's head and recorded externally, or whether they emerge from an internal dialog between the designer and their external representations, or emerge through a shared set of design documents that provide a scaffold for different specialists' thought processes—or all three. The point is that the current intellectual task is being transformed, along with the representation. Chapter 2 provides a general overview of the technology and its ability to support these kinds of processes.

A change in representation is, in the end, only an instrumentality for achieving the ends, in this case, the development and realization of an architectural project. Does BIM facilitate designing for sustainability? Does it facilitate more efficient construction methods? Does it support higher quality design? These are the value questions that this chapter attempts to address. Design, though not adequately taught this way, is a team effort, involving the owner/client, the architect and specialist designers and engineers, and with growing recognition, others involved in the project's fabrication and erection. A project's realization involves prodigious levels of coordination and collaboration.

Coordination and collaboration involve multiple levels of communication. At one level, it involves communication between people regarding values, intent, context, and procedures. At another level, it also involves different tool representations and the need for data exchange between tools. Different members of a project team use different digital tools to support their particular work. BIM significantly benefits both of these. The 3D models that are the basis of BIM provide major improvements in the communication of spatial layouts for people. 3D layouts not in the orthogonal plane could only be approximated on 2D planar projections. Recent practice came to rely on onsite correction of complex layouts because the paper-based representations

## Outline of Traditional Architectural Services

### Feasibility Study

Nonspatial quantitative and textual project specification, dealing primarily with cash flows, function or income generation; associates areas and required equipment; includes initial cost estimation; may overlap and iterate with predesign; may overlap and iterate with production or economic planning.

### Predesign

Fixes space and functionality requirements, phasing and possible expansion requirements; site and context issues; building code and zoning constraints; may also include updated cost estimation based on added information.

### Schematic Design (SD)

Preliminary project design with building plans, showing how the predesign program is realized; massing model of building shape and early rendering of concept; identifies candidate materials and finishes; and identifies all building subsystems by system type.

### Design Development (DD)

Detailed floor plans including all major construction systems (walls, façades, floor, and all systems: structural, foundation, lighting, mechanical, electrical, communication and safety, acoustic, etc.) with general details; materials and their finishes; site drainage, site systems and landscaping.

### Construction Detailing (CD)

Detailed plans for demolition, site preparation, grading, specification of systems and materials; member and component sizing and connection specifications for various systems; test and acceptance criteria for major systems; all chaises, block-outs, and connections required for intersystem integration.

### Construction Review

Coordination of details, reviews of layouts, material selection, and review; changes as required when built conditions are not as expected or due to errors.

were fundamentally inadequate. Those issues are eliminated with virtual 3D modeling of the project's systems' layouts. Everyone can easily see how their work relates to others'. At the data exchange level, building models, because of the machine readability and explicit coding, support automatic translation of building model data, improving the availability of design information for other uses throughout the design and later construction processes. While the current realization of this goal is inadequate, as described in Chapter 3, the goal will see its realization, possibly using BIM model views.

These new communication capabilities provide new opportunities for improving what designers produce. It potentially supports automatic interfaces with analysis and simulation programs that provide feedback to the design development process. Earlier coordination with fabricators through building models is expanding the level of coordination with construction. These changes will, in turn, affect the way designers think and the processes they undertake. These changes have only just begun. But even at this early stage, BIM is redistributing the time and effort designers spend in different phases of design.

This chapter addresses how BIM influences the entire range of design activities, from the initial stages of project development, dealing with feasibility and concept design, to design development and construction detailing. In a narrow sense, it addresses building design services however this role is realized: carried out by autonomous architectural or engineering firms; as either part of a large integrated architecture/engineering (AE) firm or through a development corporation with internal design services. Within these varied organizational structures, a wide variety of contractual and organizational arrangements may be found. This chapter also introduces some of the new roles that will arise with this technology and considers the new needs and practices that BIM supports.

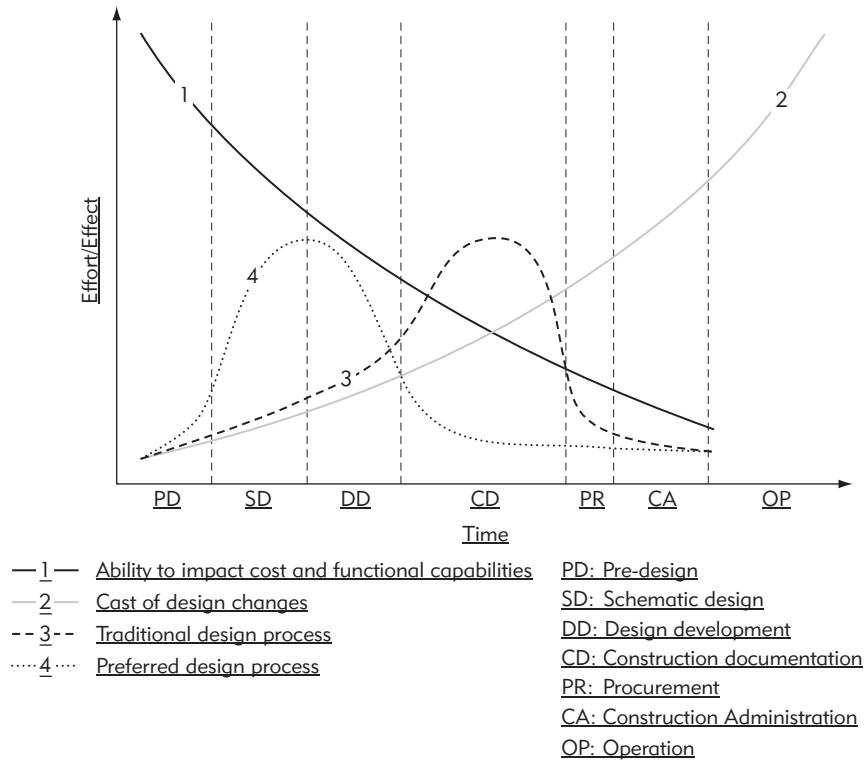
---

## 5.2 SCOPE OF DESIGN SERVICES

Design is the activity where a major part of the information about a project is initially defined. A summary of the services provided within the traditional phases of design is shown in Figure 5-1. Antitrust laws prohibit the AIA publishing standard fee structures, but the earlier traditional contract for architectural services suggests a payment schedule (and thus the distribution of effort) to be 15 percent for schematic design, 30 percent for design development, and 55 percent for construction documents and project supervision (AIA 1994). This distribution reflects the weight traditionally required for the production of construction drawings.

**FIGURE 5-1**  
 Value added, cost of changes, and current compensation distribution for design services.

Attributed to Patrick MacLeamy, CURT (2007).



Due to its ability to automate standard forms of detailing, BIM significantly reduces the amount of time required for producing construction documents. Figure 5-1 illustrates the general relationship between design effort and time, indicating how effort is traditionally distributed (line 3) and how it can be redistributed as a result of BIM (line 4). This revision aligns effort more closely with the value of decisions made during the design and build process (line 1) and the growth in the cost of making changes within the project lifetime (line 2). The chart emphasizes the impact of early design decisions on the overall functionality, costs, and benefits of a building project. The fee structure in some projects is already changing to reflect the value of decisions made during schematic design and the decreased effort required for producing construction documents. The change in distribution of effort also makes assumptions about delivery method and contracting. Here we explore some of these implications.

### 5.2.1 Collaborative Forms of Project Delivery

Traditional forms of contract rely on two major partitions of the procurement process, called design-bid-build. Such projects typically involve the design of

the project, followed by procurement of the contractor through an open bidding process, often to obtain the lowest cost bid. For a fuller review, see Chapters 1, 4, and 6.

From a design perspective, the design-bid-build procurement process is based on the following now-discredited assumptions:

- Buildings are constructed using standard construction practices, well understood by both architects and contractors. Construction methods can be fully anticipated by the architects and engineers, who can optimize designs for cost and construction duration.
- Construction relies primarily on management practices that are not affected by design details.
- Design changes during construction have well-defined, discrete, and measurable impacts on the construction process.
- Design-bid-build and the lowest responsible bid provide the lowest cost project.

The inherent need to merge the expertise of architectural and engineering design with the expertise of construction in the final production documentation has led to distortion of the services offered. Current practice has been to specify the architect's drawings being limited to "design intent," with all aspects of construction detailing and coordination being resolved in an additional set of drawings, called construction coordination documents (for managing building system coordination) and shop drawings for fabrication of the actual built elements. "Design intent" drawings exist to isolate the intellectual contribution of architects and engineers from that of fabricators and constructors, and to indemnify designers from liability for design coordination and other problems.

This partition and redundant process is inefficient of time and dollars. It has also resulted in a high level of litigation on construction projects. The potential for litigation leads architects to withhold information useful for the contractor and reduce communication and collaboration because the information is not covered in the architect's liability coverage. It also results in contractors relying on design and documentation errors as a basis for profit on a project through costing of change orders. The resulting processes are dysfunctional, in the sense that they are not in the owner's interest and do not contribute to the success of a project.

Design-build contracts establish a commercial relationship between the owner/client and a single legal entity for execution of the project, which covers both design and construction. A downside of this approach is that architecture

firms, because of their low levels of capitalization, are almost always junior partners in such undertakings, which are usually led by contractors with generally greater capitalization. A related phenomenon is the coalescing of design services into large corporate entities, such as AECOM, URS, HDR, Gensler, and HOK. One of the reasons for this evolution is to address the capitalization limitation and become able to lead on large integrated projects.

Integrated Project Delivery (IPD) is a new option, quite different than both design-bid-build and design-build. In IPD projects the owner, designers, and leading contractors and suppliers enter into a single collaborative contract. The key goal of IPD is to form a cohesive team, by carefully defining common and interdependent commercial interests and the technical and social means of communication and collaboration. Another important aspect of IPD is its designation of how risks, time, and costs are allocated (see the Sutter Medical Center case study in Chapter 9). In IPD contracts architects and engineers are full partners, accepting potential costs and benefits within the project. This is an important change because it potentially provides a financial mechanism for designers to benefit from any contribution of design performance to construction performance. If the project is completed early, or below the target cost, the designer benefits with the other members of the collaborative team. These construction performance aspects open the door to measurement of other forms of design performance, such as energy use, organizational performance within the facility, and sustainability. These will become central to the development of design services in the future.

Collaborative single unit contracting for projects offers a new basis for contracting for services by architects. These changes to design practices, project contracting, methods of delivery, and of roles, transform architecture in fundamental ways. Yet the design services provided do not disappear, but rather become more articulated and sharpened.

### **5.2.2 The Concept of Information Development**

Building projects begin at different levels of information development, including definition of the building's function, style, and method of construction. At the low end of the information development spectrum are franchise buildings, including warehouses and roadside service stations, often called "big boxes," and other buildings with well-defined functional properties and fixed building character. Sometimes the building is even predesigned and only needs adaptation to a particular site. With these, minimal information development is required, and the client knows ahead of time what is going to be delivered. Knowledge of the expected outcome is prescribed, including design detailing, construction methods, and environmental performance analyses.



At the other end of the spectrum—involving the highest level of information development—are owners interested in developing facilities for new social functions or attempting to rethink existing functions, such as combining an airport with a seaport, an undersea hotel, or a theater for experimental multimedia performances. Other instances of high information development involve agreements between the owner and designer to explore the application of nonstandard materials, structural systems, or environmental controls. One of the case studies in Chapter 9—the Aviva Stadium—is an excellent example of a high information development project. Their respective functions led to the development of new and untried systems that were generated from first principle analyses. For some time, progressive architecture firms and students have expressed an interest in fabricating buildings using nonstandard materials and forms, following the inspiration of Frank Gehry, Sir Norman Foster, and others. These projects involve higher levels of information development in the short term, until such cladding or construction practices become part of the arsenal of standard practices. The development of initial master designs for projects that will be replicated as branch buildings of a chain also often involve high information content.

In practice, most buildings are functionally and stylistically a composition of well-understood social functions, with some variations in detail practices and procedures, styles, and image. On the construction side, most architecture conforms to well-understood construction practices, with only occasional innovations regarding materials, fabrication, and onsite or offsite assembly. That is, they are largely conventional projects with a few areas of new information development, often reflecting site conditions. Owners are just beginning to understand the issues of level of information development in contracting for design services. In projects with well-defined data for function and construction, the initial phase may be abbreviated or omitted, with design development (DD) and construction detailing (CD) being the main tasks. In other instances, feasibility, predesign, and schematic design (SD) may be of critical importance, where the major costs and functional benefits are determined. Different levels of information development justify different levels of fees.

The scope of design services, considered from the level of information development, can be simple or elaborate, depending on the needs and intention of the client. Traditionally, the level of information development is conveyed in the scope of contracts that define architectural services, as shown in the highlighted box on the next page, “Range of Often Used Technical Services” and the range of special services, some of which are listed above. While some of the services listed in this box are carried out by the primary design firm, they often are undertaken by external consultants. In a study of collaborative

## Range of Often Used Design Technical Services

Financial and cash flow analyses

Analysis of primary functions including services in hospitals, rest homes, airports, restaurants, convention centers, parking garages, theater complexes, and so forth

Site planning, including parking, drainage, roadways

Design and analysis/simulation of all building systems, including:

- Structure

- Mechanical and air handling systems

- Emergency alarm/control systems

- Lighting

- Acoustics

- Curtain wall systems

- Energy conservation and air quality

- Vertical and horizontal circulation

- Security

Cost estimation

Accessibility assessment

Landscaping, fountains, and planting

External building cleaning and maintenance

External lighting and signage

architectural services (Eastman et al. 1998) with the firm of John Portman and Associates in Atlanta, a large building project in Shanghai was found to include over twenty-eight different types of consultants.

From this overview, we can appreciate that building design is a broad and collaborative undertaking, involving a wide range of issues that require technical detailing and focused expertise. It is in this broad context that BIM must operate, supporting collaboration at both the human and social scale, and at the computation and model level. We can also see from the diversity of contributors that the main challenge in adopting BIM technology is getting all parties of a design project to engage in the new methods of working, and for documenting and communicating their work in this new representation. In the end, everyone will have to adapt to the practices associated with this

new way of doing business; it will be the new standard practice. This point is emphasized—implicitly and explicitly—in the case studies in Chapter 9.

---

### 5.3 BIM USE IN DESIGN PROCESSES

The two technological foundations of building information modeling reviewed in Chapters 2 and 3—parametric design tools and interoperability—together with the growing array of BIM tools for specific functions, offer many process improvements and information enhancements within traditional design practices. These benefits span all phases of design. Some new uses and benefits of BIM have yet to be conceived, but several tracks of development have evolved far enough to demonstrate significant payoffs. Here, we consider the role and process of design from three of those viewpoints which apply in varying degrees to different projects, depending on their level of information development.

The first viewpoint addresses **conceptual design**, as it is commonly conceived. The importance and refocus on concept design is well articulated in the MacLeamy curves presented in Figure 5–1. Concept design determines the basic framework of the design to be developed in later stages, in terms of its massing, structure, general spatial layout, approach to environmental conditioning, and response to site and other local conditions. It is the most creative part of the design activity. It brings to bear all aspects of the project, in terms of its function, costs, construction methods and materials, environmental impacts, building practices, cultural and aesthetic considerations, among others. It anticipates and considers the full range of expertise of the design team.

A second viewpoint addresses the **use of BIM for design and analysis** of building systems. *Analysis* in this respect may be thought of as operations to measure the fluctuations of physical parameters that can be expected in the real building. Analysis covers many functional aspects of a building's performance, such as structural integrity, temperature control, ventilation and air flows, lighting, pedestrian circulation, acoustics, energy distribution and consumption, water supply and waste disposal, all under varied use or external loads. These simulations and assessments are carried out by the specialists on the design team, using detailed analysis models with technical input requirements. This viewpoint concerns collaboration with the various professions involved supported by integration of the analysis software those professions utilize. They, in turn, produce the design layouts that are used to plan and coordinate the various systems. The collaborations span from late concept design through to construction-level modeling. In exceptional cases involving high-level information development, the early design process can involve experimental analyses

of structure, environmental controls, construction methods, use of new materials or systems, detailed analyses of user processes, or other technical aspects of a building project. In these cases, a design in need of analysis is not provided, but rather problems are defined as the design of newly conceived system components, responding to a new or more articulated set of performance requirements.

The third viewpoint is the conventional BIM viewpoint of its use in **developing construction-level information**. Building modeling software includes placement and composition rules that can expedite the generation of standard or predefined construction documentation. This provides the option of both speeding up the process and enhancing quality. Construction modeling is a basic strength of current BIM authoring tools. Today, the primary product of this phase is construction documents. But this is changing. In the future, the building model itself will serve as the legal basis for construction documentation. This last viewpoint involves design and construction integration. At the more obvious level, this view applies to well-integrated design-build processes in conventional construction, facilitating fast, efficient construction of the building after design, or possibly in parallel with it. This phase also addresses generating input for fabrication-level modeling. In its more ambitious aspect, this view involves working out nonstandard fabrication procedures, working from carefully developed detailed design models supporting what mechanical designers call “design for fabrication.”

In the sections that follow, these viewpoints are described in greater detail. In lieu of the milestones in traditional design contracts, we consider these three broad areas with an understanding of the fluidity of changes inherent in current design development sequences. We also address a number of practical issues: model-based drawing and document preparation; development and management of libraries; integration of specifications and cost estimation. The chapter concludes with some practical issues of design practice: selecting a BIM authoring tool, training and introduction into projects, and issues of staffing.

### 5.3.1 BIM-Based Concept Design

Conceptual design typically involves development and refinement of the building program—the specification of the project in terms of spatial area, functions, types of construction, and the basic assessment of its functional and economic viability. Architects are sometimes involved in the development of the building program; more often, they are provided with an initial one that needs elaboration. After building program elaboration, the core of conceptual design is generated in the project’s basic building layout in floor plans, its massing and general appearance, determining the building’s placement and

orientation on the site, its structure and its internal environmental quality, and how the project will realize the basic building program, taking into account its social, neighborhood, and site context.

These initial decisions of program and concept are of tremendous importance to the overall project, as shown in Figure 5–1. They largely determine the cost, utilization, complexity of construction, time to deliver, and other critical aspects. They are now becoming properly recognized as fundamental and present a direct challenge to the traditional processes used in concept design.

Concept design has in the past almost completely relied on the experience and expertise of the lead designer, working from her or his knowledge and intuition, with feedback from the other members of the design team. At this stage, because of the requirement of quick generation and assessment of alternatives, assessment has been made primarily intuitively, from recall. The thought process has been analogical and case related. Quickness of exploration and low cognitive demands of the tool have kept the pencil (or other paper marker) as the dominant concept design tool. Freehand sketches have been the main documentation for recording and internal communication. In the same vein, some architects argue that BIM does not support conceptual design, because of its complexity and cognitive load. We partially accept this critique. Most current BIM design applications require too much of a learning curve, have many state-dependent operations, and require attention to object-dependent behaviors. The cognitive attention demanded of their operations and user interface almost prohibit “creative exploration.”

Lightweight tools such as SketchUp®, Rhinoceros, and Bonzai3d, however, have been accepted as concept design tools. These tools focus on quick 3D sketching and form generation. They facilitate communication of spatial and visual considerations by the design team. They do not have building object types and have no object type behavior, so geometry operations apply to all shapes, reducing complexity to the user. Some limit their surfaces to NURBS (Non-Uniform Rational B-Splines), a freeform surface type that can represent a very broad range of surfaces, including simple planar and spherical surfaces. These tools support reasonable object complexity and quick feedback allowing intuitive visual assessment. With repeated use they can be learned so as to become “invisible” in the designer’s thinking process. As standalone tools, they only partially responded to the challenge to concept design, of empowering the quality of decision-making. These limitations are changing, however. They have evolved significantly since the release of the previous version of this book and the tools have growing features and capabilities.

Other software tools support concept design focusing on a particular approach to development, such as spatial programming or energy usage or

financial feasibility. The companies providing BIM platforms are also aware of the perceived limitations of their tools and have included concept design capabilities that can compete with the sketch-level tools in this market area. This section reviews each of these types of products to examine their perceived role in concept design.

### ***3D Sketching Tools***

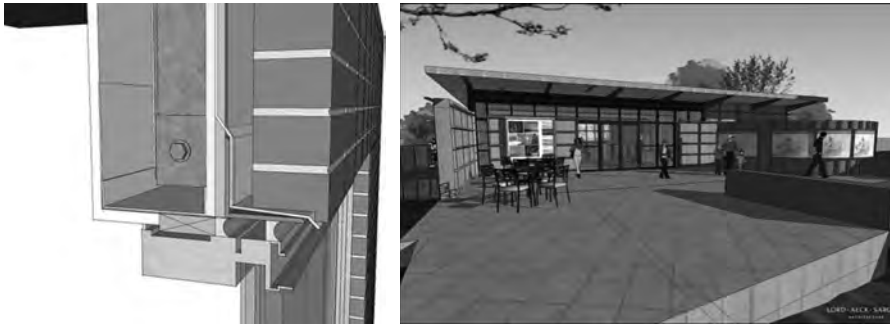
Here we offer quick overviews of SketchUp, Rhino, and BonZai, paying special attention to the workflows that are developing around them to support BIM functionality.

#### *SketchUp*

Google SketchUp® is a favorite sketch and exploration tool for many architects. It started as a startup in 1999 and made a strong name for itself before being acquired by Google in 2006. It began as a surface modeler with a very intuitive user interface. Its entry-level system is free but its nonfree professional version has increasingly powerful functional capabilities. It runs on both Windows and the Mac. Its current release is Version 8. We focus this review on the Pro version.

The base capability of SketchUp is its ease for defining a 3D line and stretching it into a surface that aligns with other points in space, supporting easy-to-use direct manipulation. Lines can be used to define a polygon on a surface that can be extruded into or above the surface, to punch holes or define new shapes. Dimensioning feedback allows a user to be precise or vague. SketchUp allows 3D shapes and buildings to be defined quite simply, with minimal or no training. See Figure 5–2. There are large libraries of predefined shapes, in Google 3D Warehouse and Form Fonts. The free SketchUp Viewer supports display of SketchUp models. SketchUp supports Ruby Script and a SketchUp System Development Kit (SDK) for creating plug-ins. There are over 100 plug-ins that greatly extend SketchUp functionality, most of which work with both basic SketchUp and Pro. Building Maker is a free extension for defining and uploading 3D photo-textured building models to Google Earth.

SketchUp Pro provides both 2D drawing generation from a model and interfaces to other applications through various file formats. The free Layout 3 plug-in supports the generation of dimensioned drawings from a 3D model SketchUp model, while StyleBuilder provides filters that stylize a model rendering in terms of drawing style. It supports Dynamic Components that allows associating attributes with entities. Collections of faces can be defined as “objects.” With Version 8, well-formed groups of surfaces can be turned into solid—and can have associated properties. The uses of these solid objects and their export into other tools will surely become fuller in succeeding releases.

**FIGURE 5-2**

SketchUp Layout, style, and editing examples. (See color insert for full color image.)

Left image: Copyright JE Dunn Construction Company. Right image: Chattochochee Nature Center–Discovery Center. Image courtesy of Lord Aeck & Sargent Architecture.

An important plug-in is IES VE. It allows the simple construction of a building, as single-line or double-line walls (actually thermal zones) on slabs that are used for the energy analysis and carbon assessment. These are assigned properties to designate their thermal behavior and with location and orientation, IES uses APACHE-Sim to run quick “indicative” energy performance for both heating and cooling. Other IES tools address solar gain, sun shading, water, and carbon use. Another similar application is OpenStudio that provides a similar interface to EnergyPlus mapped through the IDF input representation. The new OpenStudio Version 1.0.5 supports smart matching of zonal interfaces, assignment of internal space loads, and other enhancements. A third option is Greenspace Research’s Demeter plug-in. It responds to the gEnergyEPC requirements in the United Kingdom. It generates a common gbXML input interface, similar to ones developed for Revit, ArchiCAD, and Microstation. It appears that all three plug-ins reported here require a custom-developed version of the SketchUp model to support energy interfacing and manual assignment of properties for undertaking the simulations.

SketchUp Pro can read as background DXF, DWG, and IGES geometry input. It can also import IFC geometry—for some types. SketchUp Pro also supports export of 3DS, AutoCAD DWG, AutoCAD DXF, FBX, OBJ, XSI, and VRML (for the functionality of these file formats, see Chapter 3). Some of these can be read into BIM platforms and the geometry recreated from the imported background.

The workflows around SketchUp are not yet very extensive or user-friendly, limited to the geometry input for energy analysis. Each step requires data entry and manual manipulation. But these incremental steps show they are filling in a path for smooth flows into building models.

### Rhinoceros

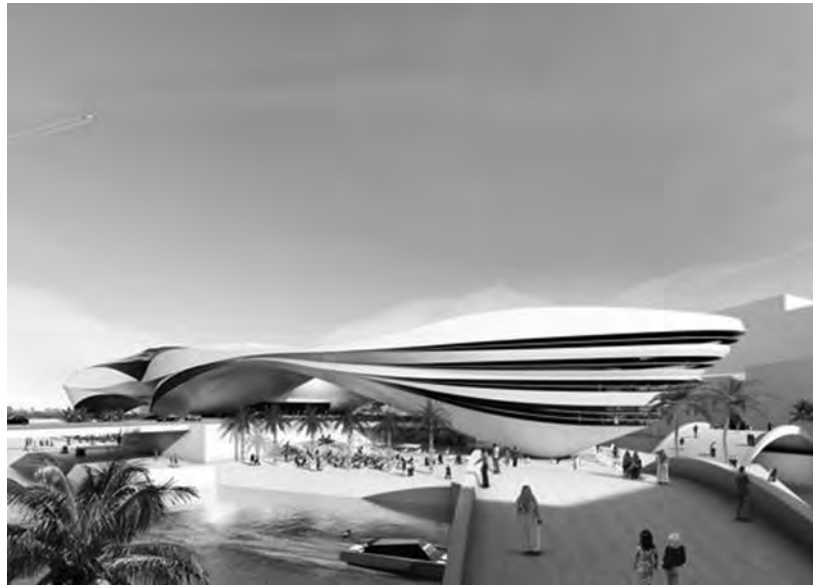
Rhinoceros® is a popular, employee-owned NURBS geometric surface modeling tool by McNeel ([www.en.na.mcneel.com/default.htm](http://www.en.na.mcneel.com/default.htm)). Rhino is a very

attractive system for architects, industrial designers, animators, jewelry makers, and others interested in 3D freeform modeling. Rhino supports many surface modeling capabilities, for generating, editing, viewing, combining, and analyzing simple or complex surface forms. See Figure 5–3. It supports operations for creating and editing of curves and joining surfaces. These are used for

**FIGURE 5–3**

Design can be freeform or structured in Rhino.

Images of external skin and interior circulation in project for Museum of Middle Eastern Modern Art, Abu Dhabi, UAE, by UNStudio, Amsterdam, the Netherlands. Rendered by Render-taxi, Aachen, Germany.





designing many types of complex forms, including building skins, cast concrete forms, and various interior forms and fixtures. Rhino supports generating solid primitives and combining sets of surfaces into solids. Solids can be edited with Boolean operations and by extracting surfaces. Surfaces can be converted to meshes. Surfaces and shapes may be analyzed and dimensioned. Rhino supports reasonable projection of forms to a plane and adding drafting annotation. With care, users can define large and complex building forms.

Rhino is a very open system, allowing easy user customization with both Rhinoscript, a version of Visual Basic scripting language, and Grasshopper, a Rhino-specific scripting language, that requires little or no computing background. An easy beginning in scripting is to capture operations in a history file of operations, then automatically repeating them. In addition to making your own scripts, there is a large library of several hundred plug-ins, many supporting architectural use. This includes Paracloud Modeler and Paracloud Gem that enable generative workflows for managing arrays of objects parametrically ([www.paraclouding.com](http://www.paraclouding.com)). Savannah3D provides libraries of architectural interior objects for populating models. Rhino supports a wide range of rendering engines, as plug-ins, including V-ray, Lightworks, Maxwell, and others. Geometry Gym (<http://ssi.wikidot.com/examples>) provides interfaces to structural modeling applications. Available analysis model formats include OasysGSA, Robot, SAP2000, Sofistik, SpaceGASS, and Strand7. Neutral detailing format SDNF is available, with development on CIS/2 and IFC (for the functionality of these file formats, see Chapter 3). Other proprietary formats such as REVIT are underway.

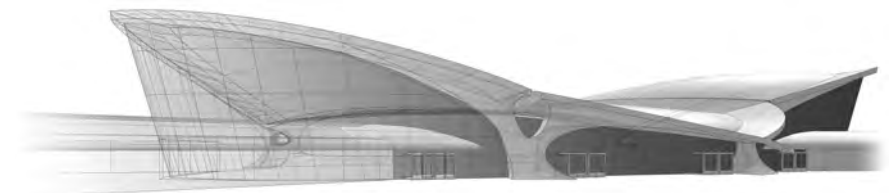
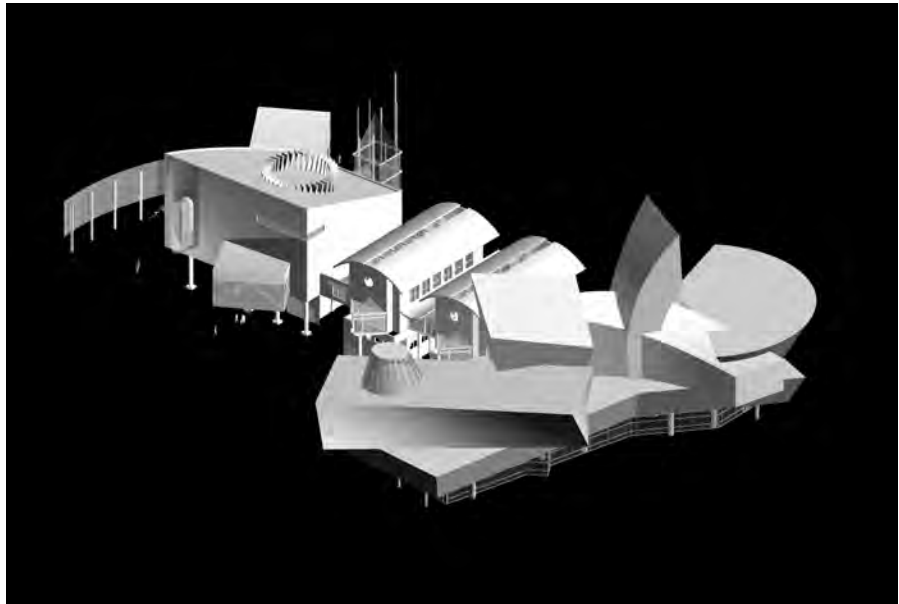
A particularly interesting tool is VisualARQ. It supports turning Rhino objects into BIM objects, of the following classes: Wall, Slab and Roof, Column, Door and Window, and Space. Spaces can be reported in a Table, for space program validation. VisualARQ also provides default parametric object classes for the different types described here. Currently in development and beta release is an IFC Export Module. It supports converting the six object classes in VisualARQ into IFC models for importing into production BIM tools or to analysis applications that accept IFC input.

With the plug-ins, Rhino appears to provide capabilities for exploratory architectural design, followed by the incremental conversion of Rhino's surfaces into solids and on into VisualARQ's building elements and Geometry Gym's structural elements. These can then be exported into IFC for production work. This provides a potentially very attractive workflow.

IFC interfaces are supported with the following concept-level design applications: For cost estimation: Timberline, U.S. Costs, Innovaya; for spatial program validation: Solibri Model Checker and Trellegence. While there are Web listings for these interfaces, it is unclear whether they are supported in current releases.

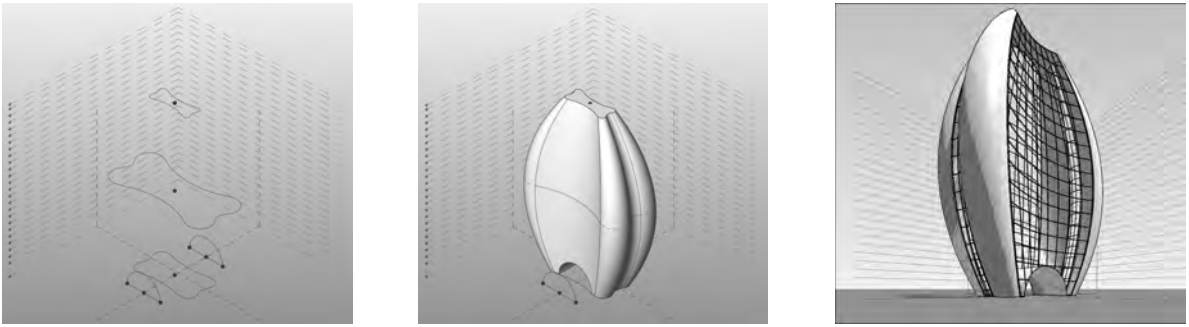
**FIGURE 5-4**

Vectorworks supports a wide variety of massing shapes and surfaces (upper image). A design can be freeform or planar in Bonzai (lower image).



### *Bonzai3d*

Bonzai3d® is a new-generation NURBS and faceted sketch modeling tool from AutoDesSys, the company that developed formZ. Its first release was in June 2009 and recently came out with its second full release. Bonzai3d is a solids modeling sketch tool that has very easy-to-use direct manipulation editing operations, like SketchUp. Indeed, much of the information about Bonzai3d discusses its style of operation as being like SketchUp. Being a solid modeling tool, however, many operations are easier, for instance, making thick walls with all the closing faces is managed automatically. Because it is NURBS-based, it supports many operations that are similar to Rhino, although the operations are different. Bonzai3d also supports surface modeling; an example is shown in Figure 5-4 (lower). For architects, it defines a few parametric assemblies: stairs, windows and doors, and roofs. It incorporates Renderzone for quick rendering and has



**FIGURE 5-5** Revit mass objects can have freeform shapes then become more detailed with added object types. Model images made available by David Light—Revit specialist, HOK London.

access to Lightworks, Maxwell, and others through external file formats. These formats include DWG, DXF, FACT, and OBJ, SAT and STL, and 3DS and COLLADA. At this time, a scripting language for Bonzai is not released.

### ***Sketching with BIM Applications***

The perceived limitations of BIM applications have been recognized by their developers. Several of them have developed concept-level design exploration tools using generic type objects, called “mass” or “proxy” objects. These can be parametrically customized to define families of shapes. They are meant to fill the void regarding BIM’s weakness to support freeform shapes, particularly as the basis for generating building skins which then can be refined in downstream design, or for the generation of grills and other types of screens. These freeform tools also support partitioning of these shapes into floor levels and into panels for “skinning.” For example, Revit 2011 added new capabilities to its massing tool allowing a greater range of freeform edit operations and ways to put grid on its surface and to assign parameterized objects or shapes to the grid (see Figure 5-5). ArchiCAD and Vectorworks both provide a similar capability using Cinema 3D. A Vectorworks example is shown in Figure 5-4 (upper). Bentley Architecture’s Generative Components is another but more powerful example. The Aviva Stadium case study in Chapter 9 is an outstanding example.

These sketching tools also have potential interfaces to energy analysis, for example Revit’s sketch design can be interfaced with Ecotect Analysis® and Green Building Studio®. Similarly, ArchiCAD supports its interfaces to EcoDesigner, an energy analysis and carbon use application, for conceptual design. Bentley also supports gbXML for online energy assessment. The capabilities of these environmental sketch models are shown in Table 5-1.

**Table 5-1** Analyses Supported from Environmental Sketch Modeling Platforms

---

<b>ECOTECT ANALYSIS—own building model plus direct link with Autodesk Revit®</b>	
DAYSIM	Lighting simulator
Radiance	Lighting simulator
CIBSE	Energy analysis
Energy+	Energy analysis
	Solar radiation analysis
	Reverberation time acoustic analysis
NIST-FDS, Fluent, and WinAir4	General interface for multiple computational fluid dynamic analyses
<b>IES—own building model plus direct link with Autodesk Revit®</b>	
ApacheCalc	Heat loss and gain
ApacheLoads	Heating and cooling loads
ApacheSim	Dynamic thermal simulation
ApacheHVAC	HVAC plant simulation
SunCast	Sun shading
MacroFlo	Simulates natural ventilation and mixed-mode systems
MicroFlo	Interior computational fluid dynamics application
Deft	Value engineering
CostPlan	Capital cost estimates
LifeCycle	Estimates lifetime operating costs
IndusPro	Ductwork layout and sizing
PiscesPro	Pipework systems
Simulex	Building evacuation
Lisi	Elevator simulation
<b>gbXML—XML link from Autodesk Revit®, Bentley Architecture, and ArchiCAD®</b>	
DOE-2	Energy simulation
Energy+	Energy simulation
Trane2000	Equipment simulation
	Building product information

---

***Sketching with Function-Specific Applications***

Other early design tools emphasize specific functional workflows. Trelligence (Trelligence 2010) provides space planning layouts with feedback on space programming against targets. Trelligence supports export and two-way links

with both Revit and ArchiCAD, and import into SketchUp. Vectorworks has its own space planning tool, as does Revit. Visio also supports space planning, in its Space Planner application. Ecotect Analysis and IES have their own standalone simple building models that allow quick schematic layout that interfaces to energy, solar gain analysis, lighting, and other forms of assessment relevant to conceptual design. gbXML provides another information flow for energy assessment. Another important area for conceptual design is cost assessment, which is offered by DProfiler (Beck Technology 2007, see Chapter 2).

Unfortunately, none of these programs provides the broad spectrum of functionality needed for general concept design, and workflows are currently rough, requiring rigid modeling conventions to be followed or alternatively restructuring of the model. A smooth workflow using these tools is not quite a reality. In practice, most users rely on one of the aforementioned software tools. Of these, few are able to interface easily and efficiently with existing BIM authoring tools.

Environmental analysis tools also require significant amounts of non-project-specific information, including details that may affect incident sunlight and any objects or effects that may restrict sunlight or views of existing structures, such as geographic location, climatic conditions, structures, or topography. This information is not typically carried within BIM design tools but by secondary analysis tools. These distributed datasets often introduce management-level problems, such as determining which analysis run gave which results and based on which version of the design. In this respect, BIM server repositories can play an important role (see Chapter 3).

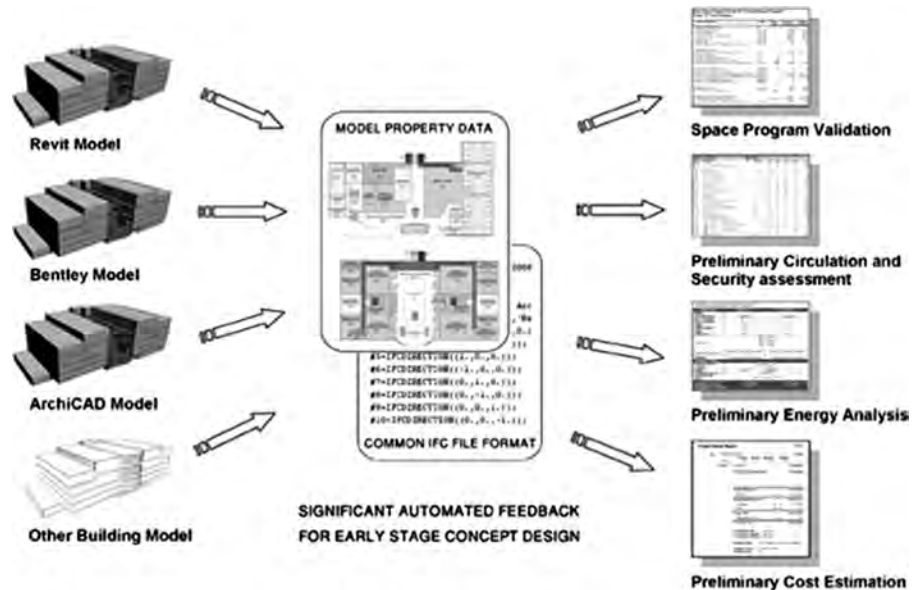
### ***An Example of Integrated Conceptual Design***

An example of preliminary concept design supported by multiple integrated assessments has been developed by work sponsored by the U.S. federal government's General Service Administration (GSA) with the College of Architecture at Georgia Institute of Technology. One of the major building type responsibilities of GSA is the construction of U.S. courthouses. The work of the Georgia Tech team specifically addressed courthouses.

The GSA has a well-defined design process, spelled out in the P-100 PBS Facilities Standards (P100 2005). The *GSA Design Guide* identifies many planning and feasibility steps prior to the selection and award of a project to an architectural design firm. Also provided is the building space program, called the Anycourt. It identifies the number and areas for the spaces within the planned building and the site. A particularly important information collection is the *U.S. Courts Design Guide*, a 400-page document (U.S. Courts Design Guide., 2007) that outlines spatial requirements, circulation, security, environmental requirements, communications, security, and other courthouse requirements.

**FIGURE 5-6**

The general configuration of the GSA Preliminary Concept Design Assessment Tool.



The first designs by the architects-engineers submitted for GSA review are called Preliminary Concept Designs. Based on one or more narratives, the architectural firm generates multiple design spatial concepts—at least three are required. More are usually generated, through refinements and iterations. In the pre-BIM world, the multiple concepts and the one or more narratives were presented in paper format, with drawings and renderings generated in varied formats. Either the architectural firm or GSA assesses each of the alternative preliminary concept designs in terms of their relation to the space program, codes, and standards, including fire and accessibility codes, fulfillment of the *U.S. Courts Design Guide* (for those matters that can be assessed at this stage), plus a preliminary cost and energy use estimate. These assessments were done by hand, by GSA staff or consultants. See Figure 5-6.

Recently, architects have begun to submit preliminary concept designs as 3D building models. Thus the opportunity to partially automate the reviews became possible. The preliminary concept designs can be generated using any of the GSA-approved BIM design tools, including Revit, Bentley Architecture, ArchiCAD, Digital Project, and Vectorworks. The model requirements for a BIM preliminary concept design are that the model consists of:

- Floor slabs defined with target thickness and floor-to-floor distances—also applied to depict roofs
- North arrow for building orientation
- Set of 3D space objects on each floor slab, defined at the departmental level without individual spaces, named at departmental level or with



**FIGURE 5-7**  
Example BIM model of a preliminary concept design for a two-story courthouse.

Credit Hugo Sheward

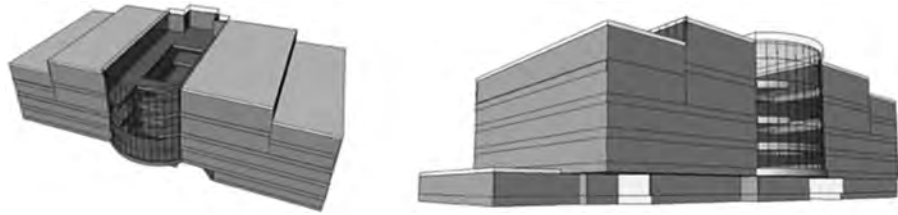
individual spaces, with space height designating ceiling height; walls as space separators are optional

- Security level for circulation spaces
- Stairs, elevators, and ramps defined by the spaces they occupy
- Exterior walls with no construction, but with percent glazing; wall thickness designates intent regarding mass and R-values
- Building entrances with doors

Example images of a preliminary concept design are shown in Figures 5-7 and 5-8.

**FIGURE 5-8**

Massing studies generated from the preliminary concept design model.



The above information provides the minimal building model information required to define a “preliminary design concept” but still detailed enough for generating meaningful performance predictions. The model information requirements are defined to be flexible and easy to produce. Each of the GSA-qualified BIM design tools support the export of a publicly readable data model of a building design, using the Industry Foundation Class (IFC) data format (IAI 2003). Given the output in IFC format, automated interfaces (shown in Figure 5–6) to that model have been developed for the following automated assessments:

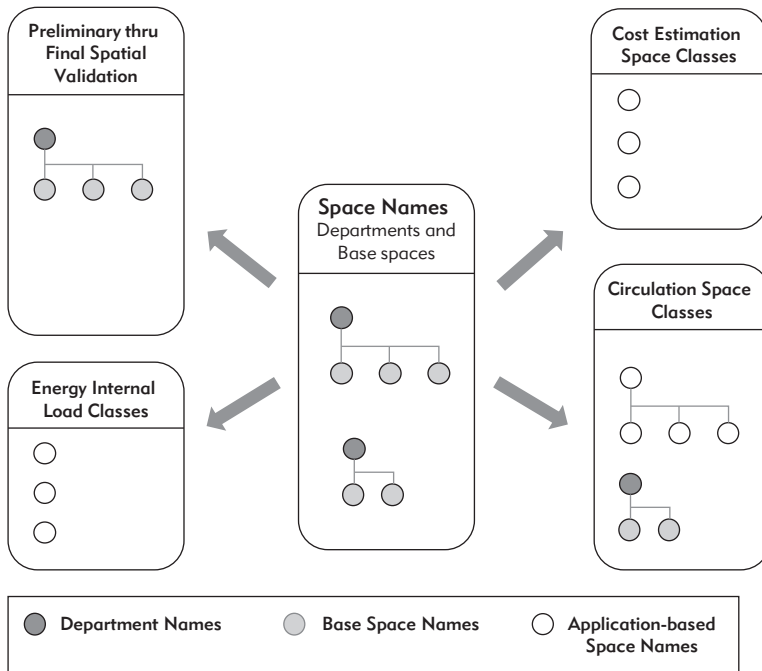
- Spatial validation of the layout, comparing target Anycourt space counts and areas with those in a concept alternative
- Circulation analysis of the building layout, based on rules extracted from the *U.S. Courts Design Guide*
- A preliminary energy assessment, using Energy-Plus
- A preliminary cost estimate, using the PACES cost estimating system

These four assessments are interfaced to the IFC model through plug-ins developed for the Solibri IFC platform. The four assessments can be undertaken in only a few minutes, greatly reducing the time needed to gain reliable feedback on design actions.

#### *Space Names for Assessment of Preliminary Concept Design*

Concept design is heavily concerned with building spaces, which are primarily identified by their names. Space layout is a fundamental decision at the concept design stage. But space names are complex, being differently named according to application fields and lifecycle stages; they have one name used in space programming, another for business rental assessment, another for cost estimating category, still others for internal energy loads, plus others. In order to address this range of uses, a master space name set was defined in our integration effort, defined on the basis of the *Courthouse Design Guide*. The master space name set is categorized into elementary and aggregation space





**FIGURE 5-9**  
Mapping relation of space names.

names, as shown in Figure 5-9. Instead of requiring the design team to explicitly assign all these different kinds of names to spaces, this master list associates all space-based space names with their other assignments, for rental category, energy load generation, and so forth. These are mapped upon interface export. This eliminates many human errors and allows preassignment for the duration of the project (Lee et al. 2010).

#### *Multiple Assessments from a Single Model*

A general syntax and content pre-check application verifies that the candidate building model has the correct objects, naming conventions, properties and other structures needed for full assessment. This pre-checker is so that an incorrect building model does not lead to meaningless analyses.

**Space program validation:** The Space Validation application checks GSA-specific rules for area calculation for comparison and reconciliation with the congressionally authorized Anycourt space program. It compares alternative layouts to the target space requirements of the space program. It also includes the efficiency and adequacy of parameters traditionally used by GSA to compare alternatives. The application generates seven different reports: summary of Anycourt comparison against actual, area summaries by tenant agencies, ANSI/BOMA areas by floor (for a description of the ANSI-BOMA space

**FIGURE 5-10**

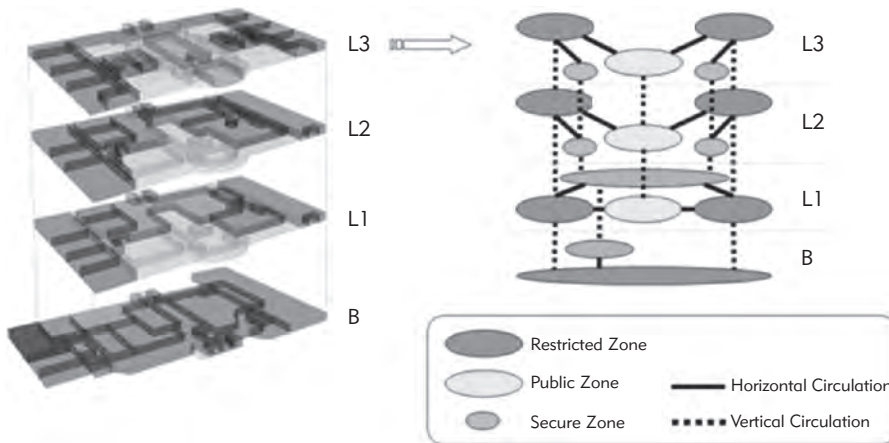
One of the space program validation reports, assessing a candidate design against the a priori space program.

Early Space Program Review for Concept Design Evaluation					
Project: GT Test Courthouse					
#	Design parameter	Type	Target Value	Concept 1 Actual Value	Concept 2 Actual Value
1	Number of Building Floors	EA		6	6
2	Total building gross area	Area (nsf)		197,269	201,005
3	Inside parking area	Area (nsf)		10,319	10,380
4	Total gross minus inside parking area	Area (nsf)		186,950	190,625
5	Total usable area	Area (usf)		159,317	161,100
6	Atrium area	Area (nsf)		622	622
7	Building Efficiency (USF/Total gross minus parking area)	Ratio (%)	67%	85%	82%
8	Number of Courtrooms	EA	9	9	9
9	Number of Special Proceedings/Appeals Courtrooms	EA	0	Not found	Not found
10	Number of Chambers	EA	11	11	11
11	Number of Inside Parking Spaces	EA	24	22	24
12	Number of Elevator Spaces on the 1st Floor	EA	TBD	6	6
13	Elevator Ratio (Total Gross Area / Number of Elevator Spaces)	Area (nsf)	25,000	32,878	32,878
14	Floor to Floor Height for Court room	Height (ft)	20	20	20
15	Maximum Ceiling Height of Courtroom	Height (ft)	16	14	16
16	Floor to Floor Height for Sp. Proceedings/Appeals Courtroom	Height (ft)	-	Not found	Not Found
17	Maximum Ceiling Height for Sp. Proceedings/Appeals Courtroom	Height (ft)	16	Not found	Not found
18	Floor to Floor Height for Office Space	Height (ft)	14	14	14
19	Maximum Ceiling Height Judges Chamber	Height (ft)	10	10	10
20	Building Skin Area	Area (nsf)		99,579	100,422
21	Total Gross Area to Building Skin Area	Ratio (%)	45-55%	50%	49%
22	Main Entrance's floor level (Ground Level)			Level 02	Level 02
23	USMS Administrative Office's floor level		2nd or upper	Not found	Not found
24	Gross Area of Prisoner Circulation and Holding Cell Area	Area (nsf)		14,902	14,902

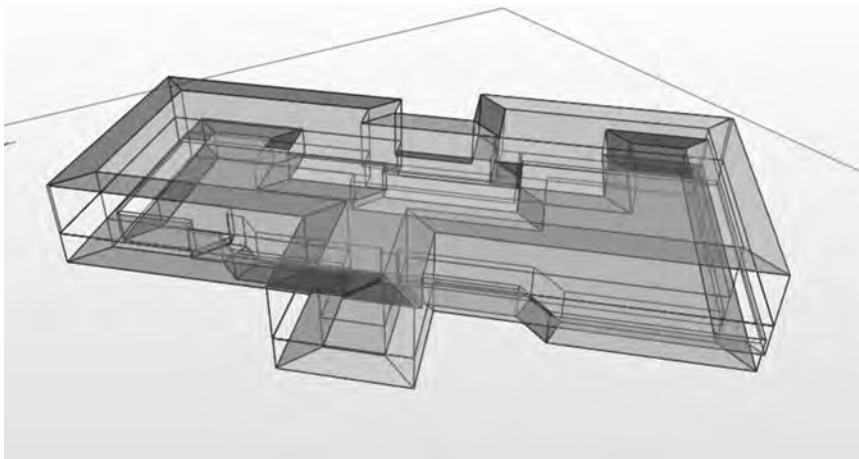
calculation method, see Section 5.3.2), GSA spatial evaluation (Figure 5-10), and circulation area by tenants.

**Preliminary circulation and security assessment:** A courthouse has three circulation systems. One is for the public (public zone), another for the judges, jury, and court staff (restricted zone), and the third is for defendants and U.S. Marshals (secure zone). They are supposed to be disjoint, so the three groups served only mix in courtrooms and a few other designated spaces. Circulation requirements are a major form determinant of a courthouse.

The *Courts Design Guide* has many circulation rules that require accessibility between two spaces in the same security zone. For instance, a rule regulates that “judge should be able to access courtroom through restricted circulation.” This rule means that the existence of a judge’s chamber and a courtroom should be in the same restricted zone. Among the circulation rules in the *Courts Design Guide*, 142 of them involve accessibility between two spaces through the same security zone. For checking the containment of spaces in a zone, the spaces adjacent and having the same security level are represented in an adjacency graph. Horizontal edges between zones are distinguished from the vertical adjacencies provided by elevators and stairs (see Figure 5-11). Tests are almost instantaneous.



**FIGURE 5-11**  
Abstraction used for  
concept design circulation  
analysis.



**FIGURE 5-12**  
Example of perimeter  
and core thermal zone  
modeling.

**Preliminary energy analysis:** An early concept design has features that significantly determine energy use. These include the building orientation; the building shell's external materials and mass, the value of insulation; and the inclusion of atria, courtyards, and skylights. At this stage designers are interested in the building's heating and cooling loads over the year, and thus the demands of HVAC to maintain human comfort. The assessment purpose is to identify any impacts of these and other features that may significantly affect energy usage and to support design decisions to improve energy performance.

In order to run a sophisticated energy simulation such as EnergyPlus with this limited information, default values are provided based on standard courthouse practices. Building zones are an important aspect of an energy model. For preliminary energy analysis, a perimeter and core thermal modeling approach is used to model the building's thermal zones (Figure 5-12). Values

for internal heat gains, such as occupant density, lighting, and equipment loads, are derived from the functional spaces in each of the building's thermal zones, such as courtroom, judge's chambers, and clerk offices.

The user has the option of making limited changes to these defaults, to test variations in the percentage fenestration of each wall, variations in the building shell's construction type, and changes in the orientation of the building. In addition, while there is minimal detail in the building model itself, the application offers preliminary means to assess various intentions. These include shading devices on different sides of the building, automatic rotation of the building to assess different orientations, external wall types, and window materials.

Results provide annual energy usage, month-by-month heating and cooling, and breakouts by energy load contributions. Some of these results are mapped to the external zone boundaries and color coded, for enhanced visualization.

**Preliminary cost estimate:** Similar to energy analysis, the intention in preliminary concept design is to determine the effect of particular design features and to gain insight into the value of and potential cost of specific design concepts. This is done by means of a cost estimation module that uses minimal the information available from building models at this early stage of design to build preliminary cost estimates.

The cost estimation module is dependent upon two main components: building model-based data and cost-driven text-based data. Data from the building model includes all IFC-related information, such as space names and their associated attributes, areas of floors, roofs and external walls, and the number of stairs and elevators. The automatic derivation of cost-relevant data is carried out in the Georgia Tech software based on inputs from the building model.

Georgia Tech uses the database developed by EarthTech's Parametric Cost Engineering System (PACES) software. Prices are then generated in Level 3 UniFormat™ categories, with quantities and in-place costs. Example output is shown in Figure 5–13. The assumed construction types and materials at the early concept design stage can then be tracked to see how the expected material quantities and costs vary as the design is detailed, providing a means of value tracking as the design progresses.

All the assessment tests rely on the space name database. These assessments have been used on several U.S. courthouse projects, including: Toledo, Jefferson City, and Bakersfield. The time that a review takes depends upon the types of energy analyses applied, which are selected by the user. Development of similar tests, for any owner/client or design firm wishing to gain better control over multiple projects, could benefit from this emerging technology.

United States Courts—Gt test courthouse						
Cost Report by UniFormat™ Level 3 Category*						
	UniFormat™ Level 1	UniFormat™ Level 2	UniFormat™ Level 3	Quantity	Unit Cost**	Cost
	A SUBSTRUCTURE					
		A10 Foundations				
			A1010 Standard Foundations			\$190,480
			A1020 Special Foundations			\$0
			A1030 Slab On Grade			\$5,639,813
		A10 TOTAL		218583	\$26.67	\$5,830,293
		A20 Besement Construction				
			A2010 Besement Excavation			\$337,523
			A2020 Besement Walls			\$1,711,276
		A20 TOTAL		218583	\$9.37	\$2,048,799
	A TOTAL			218583	\$36.05	\$7,879,092
	B SHELL					
		B10 Superstructure				
			B1010 Floor Construction			\$2,894,639
			B1020 Roof Construction			\$1,286,159
		B10 TOTAL		218583	\$19.13	\$4,180,798
		B20 Exterior Enclosure				
			B2010 Exterior Walls			\$4,133,056
			B2020 Exterior Windows			\$345,127
			B2030 Exterior Doors			\$36,341
		B20 TOTAL		218583	\$20.65	\$4,514,524
		B20 Roofing				
			B3010 Roof Coverings			\$416,234
			B3020 Roof Openings			\$116,578
		B30 TOTAL		218583	\$1.9	\$532,812
	B TOTAL			218583	\$40.11	\$9,228,134
	C INTERIORS					
		C10 Interior Construction				
			C1010 Partitions			\$3,087,582
			C1020 Interior Doors			\$1,136,998
			C1030 Specialties			\$934,193
		C10 TOTAL		218583	\$23.6	\$5,158,774

**FIGURE 5-13** Example output for cost estimation.

The Automated Preliminary Concept Design system reviewed here was the work of a team of PhD students at Georgia Tech’s College of Architecture. They include: Sherif Abdelmohsen, Jaemin Lee, Jin-kook Lee, Paola Sanguinetti, Hugo Sheward, and post-doctorate Yeon-suk Jeong. Chuck Eastman is the team leader.

#### *Other Issues of Conceptual Design*

For completing what has traditionally been schematic design, two other aspects of a design need to be defined: site development (including existing conditions) and typological identification of all building systems. Some BIM design tools support site planning, as listed in Table 2–1, and some environmental analysis tools support site as well as exterior solar and wind studies. Conceptual design usually involves identifying the “type” for each of the building systems, including structural, exterior envelope, energy and HVAC, lighting, and vertical circulation.

The only software currently available for representing all building systems and supporting concept-level cost estimation is DProfiler, which enables rapid composition of a concept model and generation of a cost estimate. It relies on

building type cost data that must be preconfigured in the system. DProfiler has developed a direct translator into Revit object families (see Chapter 2, Section 2.6.7).

Another aspect of understanding the building context is in capturing as-built conditions. This is a critical issue for retrofit work and remodeling. New surveying techniques, based on laser scanning and point clouds, offer a valuable new technique to capture as-built conditions. These are discussed in Chapter 8.

#### *Concept Design Summary*

Concept design tools must balance the need to support the intuitive and creative thinking process with the ability to provide fast assessment and feedback based on a variety of simulation and analysis tools, allowing more informed design. Unfortunately, each of the commercially available tools only does part of the overall task, requiring translation between them and later with the major BIM tools discussed in Chapter 2.

None of the tools available today support the full scope of conceptual design, either for designer exploration and development, or for product delivery use at schematic design-level services. On the other hand, we are beginning in a new era of assessment. When the opportunity exists to gain technical assessment of design concepts at the sketch level, for energy, costs, and some aspects of function, the interaction between design generation and assessment will become more articulated. With almost real-time feedback, the shift between cognitive resources, currently based on recall and intuition, will expand to include computational assessments and interpretation. This change will affect both the direction and quality of concept development and the cognitive process that supports it. Few architectural designers are familiar with working with such “almost real-time” feedback.

### **5.3.2 Building System Design, Analysis, Simulation, and Checking**

As design proceeds past the conceptual stage, systems require detailed specification. Mechanical systems need sizing, and structural systems must be engineered. These tasks are usually undertaken in collaboration with engineering specialists, internal or external to the design organization. Effective collaboration among these activities provides an area of market differentiation.

In this section, we review the general issues associated with applying analysis and simulation methods to design. First, we focus on the use of such applications as part of the normal performance assessment process during the detailing of building systems in the later stages of design. In contrast to the earlier applications, the applications in this phase are specific, complex, and

usually operated by technical domain specialists. They are mostly tools, not platforms, as defined in Chapter 2. We consider areas of application and existing software tools, some of the issues concerning their use and exchange of building model data between them, and general concerns relating to collaboration. We conclude by examining the special use of analysis and simulation models that explore innovative applications of new technologies, materials, controls, or other systems to buildings. It is important to note that such experimental architecture generally requires specialized tools and configurations.

### ***Analysis/Simulation Software***

As design development proceeds, details concerning the building's various systems must be determined in order to validate earlier estimates and to specify the systems for bidding, fabrication, and installation. This detailing involves a wide range of technical information.

All buildings must satisfy structural, environmental conditioning, freshwater distribution and wastewater removal, fire retardance, electrical or other power distribution, communications, and other basic functions. While each of these capabilities and the systems required to support them may have been identified earlier, their specification for conformance to codes, certifications, and client objectives require more detailed definition. In addition, the spaces in a building are also systems of circulation and access, systems of organizational functions supported by the spatial configuration. Tools for analyses of these systems are also coming into use.

In simple projects, the need for specialized knowledge with respect to these systems may be addressed by the lead members of a design team, but in more complex facilities, they are usually handled by specialists who are located either within the firm or hired as consultants on a per-project basis.

Over the past three decades, a great many computerized analysis capabilities and software tools were developed, well before the emergence of BIM. One large set of these is based on building physics, including structural statics and dynamics, fluid flow, thermodynamics, and acoustics. Many of these tools required 3D modeling of buildings. For example, structural analysis software such as GT-STRUDL has enabled structural engineers to model and analyze three-dimensional frames since 1975. Although early users had to define 3D geometry for input by listing coordinates, nodes, and members in lines of text, graphic and parametric preprocessor capabilities were added to the core structural analysis tools as soon as the necessary computer hardware became available. Thus, structural engineers have been familiar with 3D parametric modeling for a long time, including parametric constraints and definition of members by reference to parametric cross-section profiles. In this respect, 3D

parametric modeling aspects of BIM are seemingly less novel for them and one might expect adoption of BIM tools to be natural and rapid.

However, this is not the case, and rates of adoption among structural engineering practices are slower than for other construction professions (Young et al. 2008; Young et al. 2009). The explanation for this appears to be rooted in the philosophical and commercial separation that divides engineering designers and analysts, with their strict focus on building physics, from construction engineers and builders, who deal directly with the real world. The philosophical gap is reflected in the dichotomy between idealized analytical models and actual physical geometry (e.g., difference between idealizations of theoretically “pinned” or “fixed” connections versus the messy reality of connections whose behavior falls between the modeled ideals). Traditionally, structural designers model structures in ways suitable for analysis, and those models cannot be translated directly into building models that are useful for construction, because they are conceptually different. The conceptual gap exists to such an extent that in many countries, such as the United States, common practice is that the detailing of structures for fabrication is left to the builders. Professional organizations tend to reinforce this practice with narrow definitions of their members’ scope of professional services.

Yet apart from the benefits BIM provides to the overall design process through multidisciplinary collaboration, BIM can provide direct and localized economic benefit for engineers by eliminating rework and making drawing production more productive. Significant effort is required to prepare the data-sets needed to run analyses. With appropriate BIM interfaces, a model representing the actual geometry can be used to derive both the analytical model and the drawing set, thus eliminating or highly simplifying preparation of the analysis input data sets.

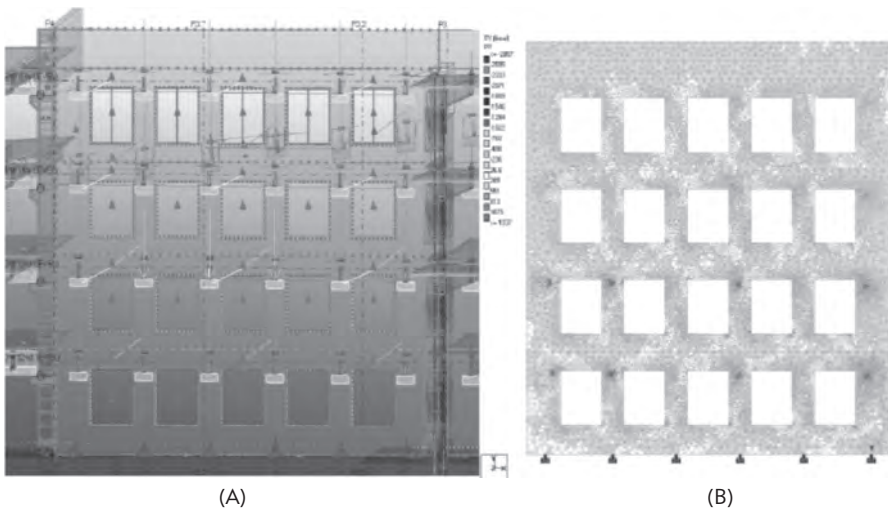
An effective interface between a BIM authoring tool and an analysis application involves at least three aspects:

1. Assignment of specific attributes and relations in the BIM authoring tool consistent with those required for the analysis.
2. Methods for compiling an analytical data model that contains appropriate abstractions of building geometry for it to function as a valid and accurate representation of the building for the specified analysis software. The analytical model that is abstracted from the physical BIM model will be different for each type of analysis.
3. A mutually supported exchange format for data transfers. Such transfers must maintain associations between the abstracted analysis model and the physical BIM model and include ID information to support incremental updating on both sides of the exchange.



These aspects are at the core of BIM's fundamental promise to do away with the need for multiple data entry for different analysis applications, allowing the model to be analyzed directly and within very short cycle times. Almost all existing building analysis software tools require extensive preprocessing of the model geometry, defining material properties and applying loads. Where BIM tools incorporate these three capabilities, the geometry can be derived directly from the common model; material properties can be assigned automatically for each analysis; and the loading conditions for an analysis can be stored, edited, and applied.

The way in which structural analyses are handled illustrates these aspects well. Because architectural design applications do not generate or represent structural members in a way that is suitable for performing structural analyses, some software companies offer separate versions of their BIM software to provide these capabilities. Revit® Structures and Bentley Structures are two examples that provide the basic objects and relationships commonly used by structural engineers—such as columns, beams, walls, slabs, and the like—in forms that are fully interoperable with the same objects in their sibling architectural BIM applications. It is important to note, however, that they carry a dual representation, adding an automatically generated idealized “stick-and-node” representation of the structure. They are also capable of representing structural loads and load combinations and the abstract behavior of connections, as connection releases, as are needed for analyses used to gain building code approval. These capabilities provide engineers with direct interfaces for running structural analysis applications. Figure 5–14 shows a model of a shear wall in a BIM tool and the results of an in-plane lateral load analysis of that wall.



**FIGURE 5–14**  
 (A) A stack of lite-wall precast pieces in a Tekla Structures model with loads defined, and (B) the same section in the STAAD PRO finite element analysis package.

Energy analysis has its own special requirements: one dataset set for representing the external shell for solar radiation; a second set for representing the internal zones and heat generation usages; and a third set for representing the HVAC mechanical plant. Additional data preparation by the user, usually an energy specialist, is required. By default, only the first of these sets are represented in a typical BIM design tool.

Lighting simulation, acoustic analysis, and air flow simulations based on computational fluid dynamics (CFD) each have their own particular data needs. While issues related to generating input datasets for structural analysis are well understood and most designers are experienced with lighting simulations (through the use of rendering packages), the input needs for conducting other kinds of analyses are less understood and require significant setup and expertise.

Providing the interfaces for preparing such specialized datasets is an essential contribution of the special-purpose environmental analysis building models reviewed in Section 5.3.1. It is likely that a suite of preparation tools for performing detailed analyses will emerge embedded within future versions of primary BIM design tools. These embedded interfaces will facilitate checking and data preparation for each individual application, as will be done for preliminary design. A properly implemented analysis filter will: (1) check that the minimum data is available geometrically from the BIM model; (2) abstract the requisite geometry from the model; (3) assign the necessary material or object attributes; and (4) request changes to the parameters needed for the analysis from the user.

The commonly used analysis/simulation applications for detailed design are shown in Table 5–2. Both public data exchange formats and direct, proprietary links with specific BIM design tools are listed. The direct links are built using middleware public software interface standards, such as ODBC or COM, or proprietary interfaces, such as ArchiCAD®'s GDL or Bentley's MDL. These exchanges make portions of the building model accessible for application development. The public exchange formats include IFC and CIS/2, which are discussed in detail in Chapter 3.

A uniform direct exchange format to support all analysis types is not likely to be developed, because different analyses require different abstractions from the physical model, with properties that are specific to each analysis type. Most analyses require careful structuring of the input data by the designer or the engineer who prepares the model.

### ***Analysis of Conformance to Building Code Requirements and Regulations***

The above review focuses on quantitative analysis dealing with the physical behavior of buildings. Less complex but still complicated criteria must also be

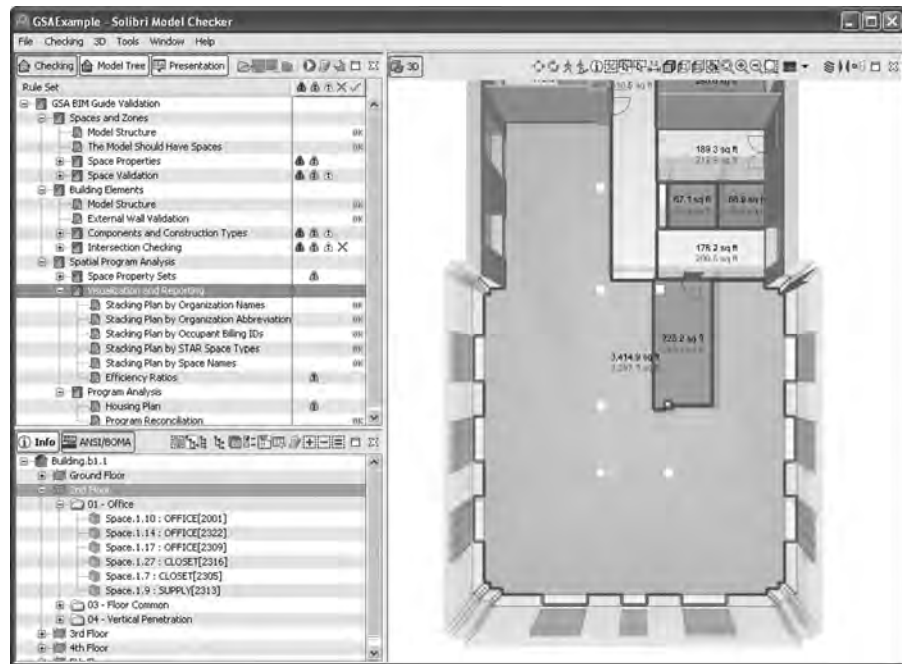
**Table 5-2** Some of the Common Analysis/Simulation Applications and Their Exchange Capabilities

	Application	Import Formats					Export Formats					Direct Links	
		C I S / 2	I F C	D X F	S D N F	S A T	G B X M L	C I S / 2	I F C	D X F	S D N F		
Structural Analysis	SAP200, ETABS	•	•					•	•				Revit® Structures,
	STAAD-Pro	•						•					Bentley® Structures
	RISA			•						•	•		Revit® Structures
	GT-STRUDL	•			•			•					
	RAM							•		•	•		Bentley® Structures
	Robobat	•	•										Revit® Structures,
Energy Analysis	DOE-2						•						
	EnergyPlus		•				•						Ecotect Analysis.
	Apache			•									IES
	ESP-r			•					•				Ecotect
Mechanical Equip- ment Simulation	TRNSYS												
	Carrier E20-II												
Lighting Simulation	Radiance			•			•						ArchiCAD®
Acoustic Analysis	Ease			•									
	Odeon			•									
Air Flow/CFD	Flovent			•		•							
	Fluent							•	•				
	MicroFlo												IES
Building Functional Analysis	EDM Model Checker		•										
	Solibri		•										

**FIGURE 5-15**

Example derivation of the ANSI-BOMA space area, for comparison with the specified program area.

Image provided courtesy of the Office of the Chief Architect, Public Buildings Service, U.S. General Services Administration.



assessed such as fire safety, access for the disabled, and building code requirements. Recently, the availability of neutral format (IFC) building models has facilitated two products supporting rule-based model checking. Solibri Model Checker™ considers itself to be a spell- and grammar-checking tool for building models. EDM ModelChecker™ provides a platform for undertaking building code checking and other forms of complex configuration assessments. EDM is the platform used in CORENET, the Singapore automated building code checking effort (CORENET 2007). Similar building code efforts are underway in Australia (Ding et al. 2006) and in the United States (ICC n.d.). A good review of rule-checking systems is provided in (Eastman et al. 2009).

Solibri (Solibri 2007) has implemented the Space Program Validation application for GSA (GSA 2006). One aspect of Space Program Validation for the area derivation of one space is shown in Figure 5-15. The application compares the program areas against the ones in the layout, based on the ANSI-BOMA area calculation method, which measures to the dominant wall's surface, not the baseline of the wall. It varies wall boundaries according to the type of space separated. Such assessment applications dealing with both qualitative and quantitative assessments will become more widely used as standard representations of buildings become more available.

### **Cost Estimation**

While analysis and simulation programs attempt to predict various types of building behavior, cost estimation involves a different kind of analysis and prediction. Like the previous analyses, it needs to be applicable at different levels of design development, taking advantage of the information available and making normative assumptions regarding what is missing. Because cost estimation addresses issues relevant to the owner, contractor, and fabricator, it is also discussed from these varying perspectives in Chapters 4, 6, and 7, respectively.

Until recently, the product or material units for a project were measured and estimated through manual counting and area calculations. Like all human activities, these involved errors and took time. However, building information models now have distinct objects that can be easily counted, and along with volumes and areas of materials, can be automatically computed, almost instantaneously. The specified data extracted from a BIM design tool can thus provide an accurate count of the building product and material units needed for cost estimation. The DProfiler system, reviewed in Chapter 2, provides a strong example of the mapping from material units in a BIM application to a cost-estimating system. Target costing with short cycletimes, as it is applied in IPD projects such as the Sutter Medical Center in Castro Valley (see Chapter 9), is an even more powerful use of BIM-enabled cost estimation. It becomes an effective guide for designers throughout the design phases.

While most BIM platforms enable immediate extraction of item counts, and area and volume calculations for many of their components and/or materials, more sophisticated quantity takeoff from a model requires specialized software, such as Autodesk's QTO (quantity takeoff) (QTO 2010) or Vico Takeoff Manager (Vico 2010). For the cost-estimation step, some of the prominent software tools offer plug-ins to various BIM platforms. These include: Sage Timberline via Innovaya (Innovaya 2010), U.S. Cost (Success Estimator 2010); Nomitech (CostOS v3.6 BIM Estimating 2010) and Vico Estimator (Vico 2010). These tools allow the estimator to associate objects in a building model directly with assemblies, recipes, or items in the estimating package or with an external cost database such as R.S. Means. A full review of cost-estimating systems is provided in Section 6.6.

The importance of cost estimation for designers is that it allows them to carry out value engineering while they are designing, considering alternatives as they design that make best use of the client's resources. Eliminating traditional practice of removing cost items at the end of a project is an important benefit of BIM and costing. Incremental value engineering while the project is being developed allows practical assessment throughout design. Target costing with short cycle-times, as it is applied in IPD projects such as the Sutter

Medical Center (see Chapter 9), is an even more powerful use of BIM-enabled cost estimation, because it becomes an effective guide for designers throughout the design phases.

### ***Simulating Organizational Performance within Facilities***

Buildings are built to house various functions, such as healthcare, business, transportation, or education. While the physical performance of a building's shell is obviously important to fulfilling its intended function, computer simulation tools can also be applied to predict the degree to which the constructed spaces will support the efficient functioning of the operations carried out within the building. These are obvious in manufacturing facilities, where the layout of operations is well understood to have an effect on efficient production, with a large literature (Francis 1992). The same logic has been applied to hospitals, based on the recognition that doctors and nurses spend a significant time each day walking (Yeh 2006). More recently, issues of developing space layouts that can support varied emergency procedures in trauma units and intensive care facilities have also been studied.

The processing time in airport security is something all travelers face and is strongly affected by airport planning. Software for simulating people flows through facilities can be addressed with such products as Legion Studio, Simwalk, and Pedestrian Simulations from Quadstone Parametrics. As the workforce becomes more oriented toward creative production, the open, friendly work environments found in Silicon Valley will become more commonplace everywhere. The increasing percentage of GDP devoted to healthcare indicates that improvements that can be generated through improved design—associated with new procedures—are an area worthy of intense analysis and study. Whether architects take up such analytical capabilities, clearly, the integration of building designs with models of organizational processes, human circulation behavior, and other related phenomena will become an important aspect of design analysis.

These issues are generally driven by owner recognition of need, and are discussed in Section 4.5.3. Motivation for such studies being undertaken as specialized design services is addressed in Section 5.4.1.

### **5.3.3 Construction-Level Building Models**

Designers can approach the development of a construction-level model in at least three different ways:

1. As traditionally conceived, the designers' building model is a detailed design expressing the intent of the designer and the client. In this view, the contractors are expected to develop their own independent construction model and documents from scratch.

2. Alternatively, the building model is regarded as a partially detailed model to be further detailed for use in all aspects of construction, planning, and fabrication. In this view, the design model is the starting point for elaboration by the construction team.
3. The design team can collaborate with contractors and fabricators from the beginning, being informed about fabrication issues as they model. They provide a model later that incorporates fabrication knowledge along with design intent.

The main reason why the first approach has traditionally been adopted by architects and engineers is to eliminate liability for construction issues by taking the approach that they are not providing construction information but only design intent. This is apparent in the text disclaimers that commonly appear on drawings, which transfer responsibility for dimensional accuracy and correctness to the contractors. Of course, technically this means that the contractor or fabricators should develop their models from scratch, reflecting the intent of the designer, and requiring repeated rounds of submittals, design reviews, and corrections.

The authors consider such practices—based strictly on design intent—to be inherently inefficient and irresponsible to clients. We encourage designers to take the second or third view, providing their model information to fabricators and detailers and allowing them to elaborate the design information as needed to both maintain the design intent and refine the design for fabrication. The benefits that derive from sharing models between designers and builders, and developing them in close collaboration, are a major driver for new procurement methods like Integrated Project Delivery (IPD—see Chapters 1 and 6 and Section 5.2 of this chapter for more details). At the same time, BIM is an essential facilitator for IPD.

The structural engineer's model of the USC School of Cinematic Arts provides an excellent example of this approach. As can be seen in Figure 5–16, the structural engineer has provided all of the structure geometry with cast-in-place concrete rebar and steel connection details. The different fabricators can all refine their details using the same model; coordination between the different systems is ensured. The Crusell Bridge (see case study in Chapter 9) clearly illustrates how a design model was carried through directly into detailing, fabrication, and installation onsite.

Almost all existing tools for generating building models support a mixture of full 3D component representation, 2D representative sections, plus symbolic 2D or 3D schematic representations, such as centerline layouts. Pipe layouts may be defined in terms of their physical layout or as a centerline logical diagram with pipe diameters annotated alongside them. Similarly, electrical conduit can be placed in 3D or defined logically with dotted lines. As reviewed

**FIGURE 5-16**

A view of a design engineer's Tekla Structures model of the USC School of Cinematic Arts. The model contains details for three subcontractors—structural steel, rebar fabricator, and cast-in-place concrete—and enables the engineer to ensure design coordination among these systems. (See color insert for full color figure.)

Image provided courtesy of Gregory P. Luth & Associates, Inc.



in Chapter 2, the building models resulting from this mixed strategy are only partially machine-readable. The level of detail within the model determines how machine-readable it is and the functionality that it can achieve. Automated clash checking can only be applied to 3D solids. Decisions regarding the level of detail required of the model and its 3D geometry of elements must be made as construction-level modeling proceeds.

Today, recommended construction details supplied by product vendors cannot yet be defined in a generic form allowing insertion into a *parametric* 3D model. This is because of the variety of underlying rule systems built into the different parametric modelers (as described in Section 2.2). Construction details are still most easily supplied in their conventional form, as drawn sections. The potential benefits for supplying parametric 3D details, to strengthen vendor control of how their products are installed and detailed, has large implications regarding liability and warranties. This issue is developed in Chapter 8. On the designers' side, however, the current reliance on 2D sections is both a rationale to not undertake 3D modeling at the detail level, and a quality control handicap to be overcome.



**Table 5–3** Building System Layout Applications

<b>Building System</b>	<b>Application</b>
Mechanical & HVAC	Carrier E20-II HVAC System Design Bentley Building Mechanical Systems Vectorworks Architect AutoCad MEP Autodesk Revit® MEP CAD-DUCT CAD-MEP CAD-MECH
Electrical	Bentley Building Electrical Vectorworks Architect Autodesk Revit® MEP CADPIPE Electrical
Piping	Vectorworks Architect ProCAD 3D Smart Quickpen Pipedesigner 3D Autodesk Revit® MEP AutoCad MEP CADPIPE
Elevators/Escalators	Elevate 6.0
Site Planning	Autodesk Civil 3D Bentley PowerCivil Eagle Point's Landscape & Irrigation Design
Structural	Tekla Structures Autodesk Revit® Structures Bentley Structural

### ***Building Systems Layout***

Different construction types and building systems involve different kinds of expertise for detailing and layout (see Table 5–3). Curtain walls, especially for custom-designed systems, involve specialized layout and engineering. Precast concrete, structural steel and ductwork are other areas that involve specialized design, engineering, and fabrication expertise. Mechanical, electrical, and plumbing (MEP) systems require sizing and layout, usually within confined spaces. In these cases, specialists involved in the design require specific design objects and parametric modeling rules to lay out their systems, size them, and specify them.

Specialization, however, requires a careful approach for integration in order to realize efficient construction. The designers and the fabricators/constructors for each system are typically separate and distinct organizations. While 3D layout during the design phase carries many benefits, if it is undertaken too early it may result in wasteful iteration. Prior to selecting a fabricator, the architects and

MEP engineers should only generate “suggested layouts,” ideally consulting a fabricator in a “design assist” role. After the fabricator is selected, the production objects may be detailed and laid out, and this layout may differ from the original due to production preferences or advantages that are unique to the fabricator. Designers and builders are beginning to deal with the issue of level of detail (LOD) for building modeling, and some have drawn up “Model Progression Specifications” that explicitly define the LOD required from designers and fabricators for each object type through each project phase (Bedrick 2008). It is reasonable to expect that such specs will become part of project contracts.

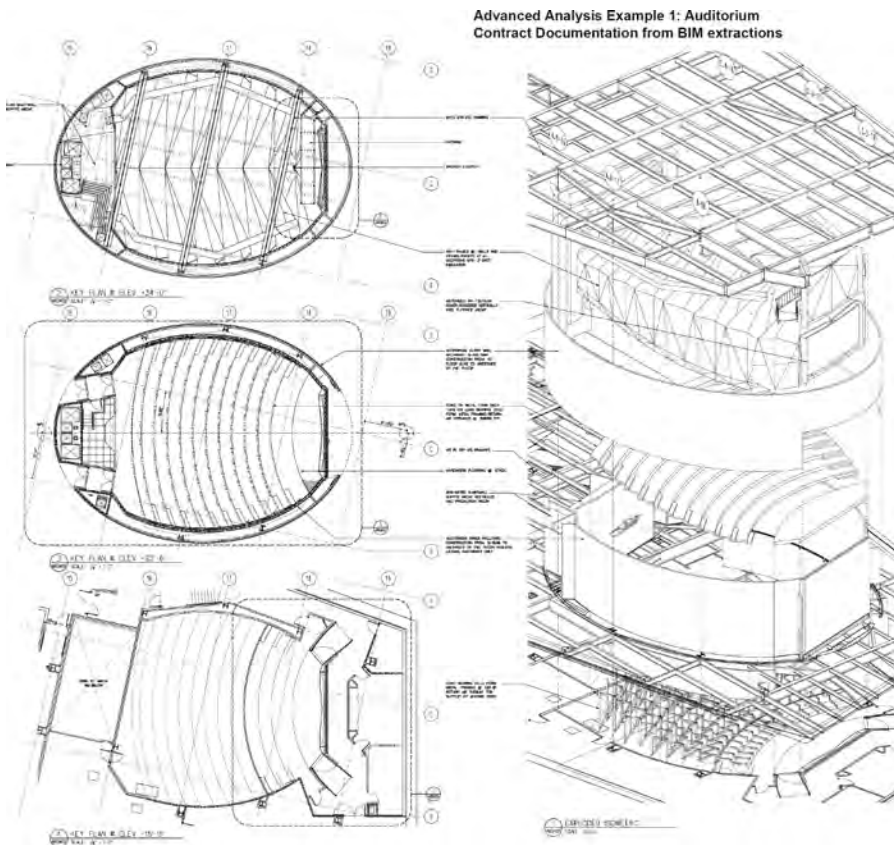
BIM tools will be most effective when used in parallel—and as seamlessly as possible—by all system designers and fabricator subcontractors. BIM tools provide strong advantages for design-build and IPD contractual arrangements for building systems. The use of construction detail-level models—where design models are used directly for fabrication detailing—will become more prevalent due to cost and time savings.

Numerous applications are available to facilitate operations within or in concert with the primary BIM design tools used by an A/E firm or consultant. A representative sample is shown in Table 5–3, which contains a list of mechanical and HVAC, electrical, piping, elevators and trip analyses and site planning applications. These support areas are undergoing rapid development by specialized building system software developers. The software under development is also being integrated with major BIM design tools and acquired by BIM vendors. As a result, BIM vendors will be able to offer increasingly complete building system design packages.

Readers interested in more detailed discussion of the role of BIM in fabrication for construction are referred to Chapter 7, which focuses exclusively on these aspects.

### ***Drawing and Document Production***

Drawing generation is an important BIM production capability, and is likely to remain so for some time. At some point, drawings will stop being the design information of record and instead the model will become the primary legal and contractual source of building information. The American Institute of Steel Construction, in its code of standard practice, has adopted contractual text saying that if the structural steel of a project is represented by both a model and drawings, the design of record is the model. Even when such changes become widespread, design firms of record will still need to produce various drawings; to fulfill contract requirements; to satisfy building code requirements, for contractor/fabricator estimation; and to serve as the documents between designer and contractors. Drawings are used during construction to

**FIGURE 5-17**

Detailed layout of the auditorium at the Merck Research Laboratories in Boston. Associated drawings included panel fabrication layout. The design was especially complicated because of the skewed structural grid.

Image provided courtesy of KlingStubbins.

guide layout and work. General drawing production requirements from BIM tools are presented in Chapter 2, Section 2.2.3.

With the development of BIM and its report-generating capabilities, once the legal restrictions on the format of drawings is eliminated, options arise that can further improve the productivity of design and construction. Already, fabricators that have adopted BIM tools are developing new drawing and report-generation layouts that better serve specific purposes. These apply not only to rebar bending and bills of material, but also layout drawings that take advantage of the 3D modeling of BIM tools. An aspect of BIM research is the development of specialized drawings for different fabricators and installers. An excellent example is provided in Figure 5-17. New representations facilitating easy interpretation of research results during design is another area where research is enhancing BIM capabilities.

The mid-term goal is to completely automate the production of drawings from a model by applying predefined templates for drawing layouts. However, a close look at special conditions makes it evident that various special cases

arise in most projects that are themselves so rare that planning for them and preparing template rules is not worth the effort. Thus review for completeness and layout of all drawing reports prior to release is likely to remain a needed task for the foreseeable future.

### **Specifications**

A fully detailed 3D model or building model does not yet provide sufficiently definitive information for constructing a building. The model (or historically, the corresponding drawing set) omits technical specifications of materials, finishes, quality grades, construction procedures, and other information required for managing the realization of a desired building outcome. This additional information is packaged as the project specifications. Specifications are organized according to types of materials within a project and/or classes of work. Standard specification classifications are UniFormat™ (of which there are two slightly different versions) or MasterFormat®. For each material, type of product, or type of work, the specification defines the quality of the products or materials and identifies any special work processes that need to be followed.

Various IT applications are available for selecting and editing the specifications relevant to a given project, and in some cases, to cross-link them with relevant components in the model. One of the earliest specification systems to cross-reference with a BIM design model was e-Specs®, which cross-links with objects in Revit®. e-Specs maintains consistency between the reference object and the specification. If the reference object is changed, the user is notified that the relevant specification must be updated. Specifications can also be associated with library objects, so that a spec is automatically applied when the library object is incorporated into the design. Another application is linkman-e (BSD 2010), which coordinates between Autodesk Revit models and specification documents compiled using the companion Speclink-e tool.

UniFormat™ defines a document structure that was conceived as a companion to a construction drawing set. One limitation of this tool is that the specification structure covers broad areas with multiple possible applications within a given building project. Logically, this limits links to one-way functions, because a single specification clause applies to multiple but somewhat diverse objects in the design. One cannot directly access the objects that a spec paragraph applies to. This limitation restricts the management of specification quality. The Construction Specification Institute (the owner of UniFormat™) is decomposing the structure of UniFormat™ to support a bidirectional relationship between building objects and specifications. The new classifications, called OmniClass™, will lead to a more easily managed structure for specification information of model objects (OmniClass™ 2007).

### 5.3.4 Design-Construction Integration

The historical separation of design from construction did not exist in medieval times and only appeared during the Renaissance. Throughout long periods of history, the separation was minimized through the development of close working relationships between construction craftspeople, who in their later years would work “white collar jobs” as draftspeople in the offices of architects (Johnston 2006). But in recent years, that link has weakened. Draftspeople are now chiefly junior architects and the communication channel between field craftspersons and the design office has atrophied. In its place, an adversarial relationship has arisen, largely due to the risks associated with liabilities when serious problems arise.

To make matters worse, the complexity of modern buildings has made the task of maintaining consistency between increasingly large sets of drawings extremely challenging, even with the use of computerized drafting and document control systems. The probability of errors, either in intent or from inconsistency, rises sharply as more detailed information is provided. Quality control procedures are rarely capable of catching all errors, but ultimately, all errors are revealed during construction.

A building project requires design not only of the built *product* but also design of the *process* of construction. This recognition lies at the heart of design-construction integration. It implies a design process that is conscious of the technical and organizational implications inherent in how a building and its systems are put together as well as the aesthetic and functional qualities of the finished product. In practical terms, a building project relies on close collaboration between experts situated across the spectrum of building construction knowledge, as well as particularly close collaboration between the design team and the contractors and fabricators. The intended result is a designed product and process that is coherent and integrates all the relevant knowledge.

Different forms of procurement and contracting are reviewed in Chapters 1 and 4. While the contractor perspective is given in Chapter 6, here we consider teaming from the designer’s perspective. Below, we list a few of the benefits of integration:

- Early identification of long lead-time items and shortening of the procurement schedule (see the Sutter Medical Center case study in Chapter 9).
- Value engineering as design proceeds, with continuous cost estimates and schedules, so that tradeoffs are integrated fully into the design rather than after-the-fact in the form of “amputations.”
- Early exploration and setting of design constraints related to construction issues. Insights can be gained from contractors and fabricators so

that the design facilitates constructability and reflects best practices, rather than making changes later with added cost or accepting inferior detailing. By designing initially with fabrication best-practices in mind, the overall construction cycle is reduced.

- Facilitating identification of the interaction between erection sequences and design details and reducing erection issues early on.
- Reducing the differences between the construction models developed by designers and the manufacturing models needed by fabricators, thus eliminating unnecessary steps and shortening the overall design/production process.
- Significantly shortened cycle times for fabrication detailing, reducing the effort required for design intent review and consistency errors.
- Greatly reducing coordination errors between systems during construction.

Part of the design-construction collaboration involves (and requires) deciding when the construction staff is to be brought on. Their involvement can begin at the project's outset, allowing construction considerations to influence the project from the beginning. Later involvement is justified when the project follows well-tried construction practices or when programmatic issues are important and do not require contractor or fabricator expertise. Increasingly, the general trend is to involve contractors and fabricators earlier in the process, which often results in the gaining of efficiencies that would not be captured in a traditional design-bid-build plan.

### 5.3.5 Design Review

Throughout design, collaborative work is undertaken between the design team and engineering and technical specialist consultants. This consultative work involves providing the appropriate project information, its use and context to the specialists to review, and gaining feedback/advice/changes. The collaboration often involves team problem-solving, where each participant only understands part of the overall problem.

Traditionally, these collaborations have relied on drawings, faxes, telephone calls, and physical meetings. The move to electronic drawings and models offers new options for electronic transfer, email exchanges, and Web conferencing with online model and drawing reviews. Regular reviews with all of the parties involved in a design or construction project can be undertaken using 3D BIM models along with tools like Webex®, GoToMeeting®, or Microsoft's Live Meeting®. Conference participants may be distributed worldwide and are limited only by work/sleep patterns and time-zone differences. Newer tools such as Bluebeam's Studio feature in its PDF Revu software (Bluebeam 2010) allow

online but asynchronous review and markup of design documents, which can be of particular use where teams are distributed across time zones. With voice and desktop image-sharing tools—in addition to the ability to share building models—many issues of coordination and collaboration can be resolved.

Colocation of all of the professional designers and the detailers for a whole project in the same office space is a new mode of collaboration that is becoming common for large and complex projects. This is a common feature of projects where IPD is used. The project team's office space usually includes an "I-Room," where different groups of people can meet to collaborate in planned or ad hoc sessions, reviewing and discussing aspects of the design in process on large screens.

Most major BIM systems include support for model and drawing review and online markups. These lightweight view-only applications rely on formats similar to external reference files used in drafting systems, but are quickly becoming more powerful. A sharable building model in a neutral format, such as VRML, IFC, DWF, or Adobe®3D, is easy to generate, compact for easy transmission, allows markups and revisions, and enables collaboration via Web conferences. Some of these model viewers include controls for managing which objects are visible and for examining object properties. Other tools, such as Navisworks and Solibri, allow multiple models, generated in a variety of authoring tools, to be overlaid and displayed together, and include features such as clash-checking and version comparison. Some of these applications are reviewed in Chapter 2.

Collaboration takes place minimally at two levels: among the parties involved, using Web meeting and desktop displays like those described above. The other level involves project information sharing. The human interaction level requires the following review capabilities, for addressing each issue identified:

1. Identification of the relevant design issue, by convention currently resolved as a camera looking at the point in space with the issue
2. Notes or data associated with the issue identifying the problem
3. Easy reporting of the issue back to the design application and users responsible for the part of the building with the issue
4. Ability to track the issues until they are resolved

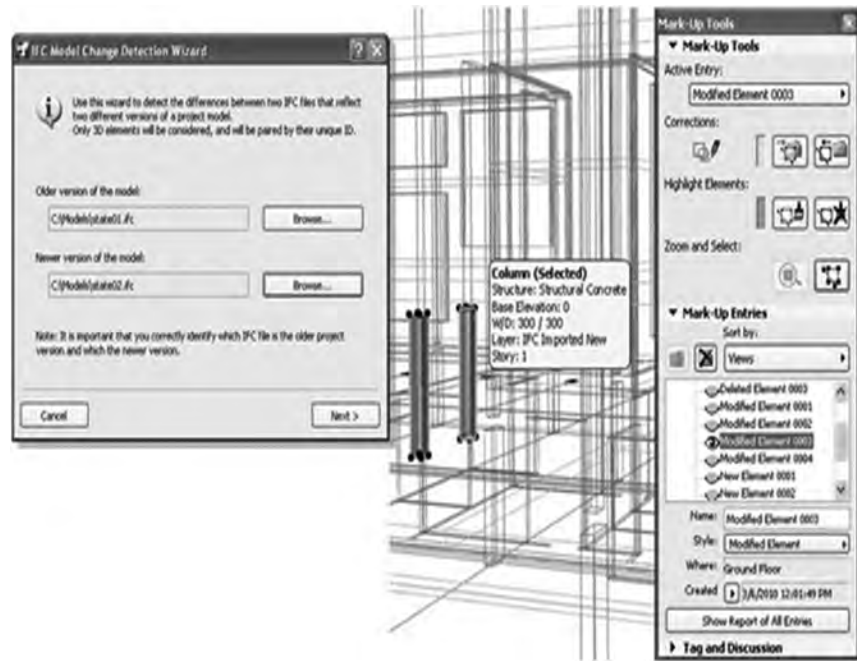
Tools such as Navisworks have provided one level of this functionality and also Solibri Model Checker. The BIM Collaboration Format, described in Chapter 3 resolves another link. These collaboration services will take new forms when BIM servers become the environments that are worked within.

The two-way capabilities at the model level have been realized in the interfaces with some structural analyses. Both the IFC and CIS/2 building data models support the definition of a globally unique ID (GUID). BIM platforms

**FIGURE 5-18**

Display of ArchiCAD 14 objects modified, added, or deleted in a structural analysis cycle. The exchanges were made using IFC files filtered for structural load-bearing content.

Image courtesy of AECbytes and Graphisoft.



such as ArchiCAD allow users to filter and select load-bearing building objects for their two-way exchanges using IFC, and support filtered display of updated objects back in the building model once objects have been returned from the structural analysis, as can be seen in Figure 5-18.

Effective collaboration using two-way workflows can generally be achieved between BIM design applications and structural analyses. Effort is still required to create effective two-way exchanges in most other analysis areas. For a fuller discussion of model exchange, interoperability and model synchronization, refer to Chapter 3.

The rationale for quicker iterations between designers and consultants is part of the lean design philosophy. Long iterations result in both sides multitasking, often on multiple projects. Multitasking results in lost time remembering issues and context of the designs on each return to a project, and makes human errors more likely. Longer iterations lead to higher levels of multitasking, whereas shorter cycles allow continuous work on projects. The result is less wasted time and better progress on each design task.

## 5.4 BUILDING OBJECT MODELS AND LIBRARIES

BIM involves the definition of a building as a composed set of objects. BIM design tools each provide different predefined libraries of fixed geometry and



parametric objects. These are typically generic objects based on standard onsite construction practices that are appropriate for early-stage design (see Table 2–1). As a design is developed, object definitions become more specific as architects and engineers elaborate them with expected or targeted performances, such as for energy, lighting, sound, cost, and so forth. Designers also add visual features to support rendering. Technical and performance requirements can be outlined so that object definitions specify what the final constructed or purchased product should achieve. This product specification then becomes a guide for selecting or constructing the final object.

Previously, different models or datasets were hand-built for the above different purposes and not integrated. It is very desirable to define an object once and use it for multiple purposes. These may be of different kinds:

- Object models of products, either generic and partially specified, or specific specifiable products
- Building assemblies that have been found to be valuable for reuse in the company's work.

The challenge is to develop an easy-to-use and consistent means for defining object instances appropriate for the current stage of design and supporting the various uses identified for the stage. Later, the selected product supersedes the specification. Thus, multiple levels of object definition and specification are needed. Throughout this process, objects undergo a sequence of refinements of performance and material properties used to support analyses, simulation, cost estimation, and other uses. Some issues of managing object properties are reviewed in Section 2.3.2. Over time, we expect these sequences to be better defined as phases, expected to be different from SD, DD, and CD, to become more structured and part of regular practice. An example is the proposed Model Level of Detail Specification (Bedrick 2008). At the end of construction, the building model will consist of hundreds or thousands of building objects—many of these can be transferred to a facility management organization to support operations and management (see Chapter 4).

#### 5.4.1 Embedding Expertise into Building Components\*

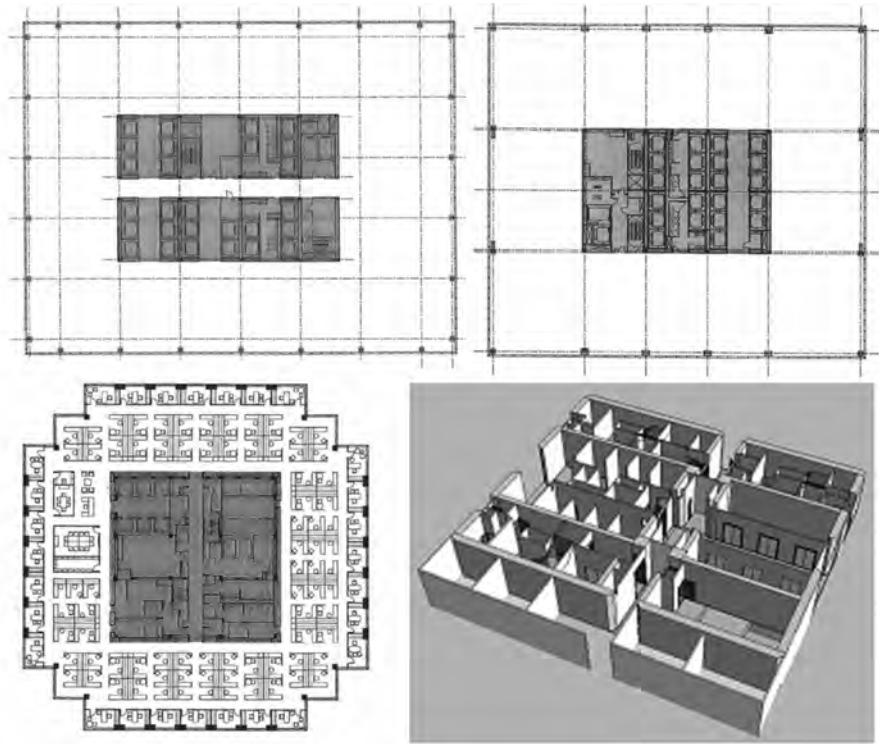
Part of the development of a design office's intellectual capital is the knowledge it brings to bear on its projects. Sometimes this expertise is embedded in a single person. Development of parametric assemblies that embed this

---

\*This section presents work conceived of and directed by Skidmore, Owings & Merrill LLP, New York and with support from Gehry Technologies and adapted from work written by Dennis Sheldon. The work and technology presented have patent(s) pending.

**FIGURE 5-19**

Sample set of four building high-rise cores of different types with a high-rise using one of them.



expertise is an important means to transfer the expertise from the individual to the organization, and to allow it to be used more widely without constant demands on the individual.

Many complex programmatic, building system, and code compliance requirements are addressed in the design of a high-rise building core. Spatial efficiency is required in the core organization to achieve operational and financial efficiencies sought of the project. Core design currently requires significant involvement by senior architects and engineers with substantial expertise in this specific aspect of architectural practice.

Core design issues are resolved by applying basic layout typologies that are repeated from project to project. A sampling of these is shown in Figure 5-20. These basic typologies are modified only slightly, based on informal yet complex design rules, to optimally address the specific occupancy loading and dimensional characteristics of the particular tower's floor plates. A detailed example of a plan layout is shown in Figure 5-21.

Gehry Technologies (GT) and SOM conducted joint research into the feasibility of developing parametric tools for the automated design and layout of tower cores.



**FIGURE 5-20**  
Detail layout of a sample building core, with partial development.

The goals of the work were to:

- Conduct basic analysis of the core design problem, to document the strategies used by senior designers in their approach to the problem.
- Based on these procedures, develop parametric BIM procedures to automate aspects of this work.
- Develop a prototype that solves identified aspects of the problem.
- Automate the generation of 2D and 3D documents either used by designers in approaching the design of tower cores or that are produced as the ultimate documentation in tower design packages.
- Provide an extensible set of methods to customize the Building Core Modeler for specific project applications.

Prior to this work, SOM had conducted an analysis of its approach to core design, including the basic core organization typologies, design rules, and modular aspects of these layouts. SOM developed an Excel-based *planning matrix* to document many of the core program requirements in spreadsheet form. Many other aspects of the problem including code and performance requirements are, of course, defined in existing, documented prescriptive rules and industry methods.

The initial task of the core automation program was to embody SOM's accumulated professional knowledge of core rules and typologies in parametric and automation terms and focus their application in a single core layout

typology, termed the “golden core.” Contract documents of recently completed projects, incorporating the golden core layout, were analyzed. Through this analysis, GT defined parametric approaches to core design automation, including technical approach, design rules, and parameters to be managed.

This analysis identified a modular layout that incorporated SOM’s planning matrix could be instantiated from floor to floor according to a set of rules. In the golden core, each floor is comprised of a series of modules of given width placed sequentially along the axis of the core. The core modules were identified as being grouped by a small set of modular dimensions that run all the way up the building.

A spreadsheet-based solver was developed that configured the overall building and individual floors. In this solver, the user sets basic parameters of the building configuration—width and depth, floor count, and so forth on a floor-by-floor basis, as shown in Figure 5–21. The building dimensions and floor count were used to determine square footage takeoffs at each floor and for the overall building height, and the number of required passenger and service elevators. Required egress widths and bathroom fixture counts were derived from rentable floor areas. An appropriate core width is determined based on the appropriate number of elevator bay modules given the floor plate width and desired lease span dimension. An elevator schedule is developed including express elevators and drop-off floors, and incorporated into a generated planning matrix for the tower configuration. User overrides can be made for many calculated parameters, including drop-off floors by elevator bank. These are generated in the table shown in Figure 5–22.

These calculations were in turn used to drive the parametric model of the specific core module. Preconfigured parametric modules were developed based on the golden core module layouts. Elevator bay counts, fixture counts, and egress distances drive the parametric configurations of these modules, as do user overrides in the planning matrix for a number of core dimensions, including chase sizes. Stair runs and floor areas were based on the input floor-to-floor heights specified, and code-compliant stairs are laid out in 3D. Two-dimensional symbols are placed for stair treads, fixtures, and doors, allowing automated drawing extraction. Texture maps were preapplied to the reconfigurable core elements to allow basic rendering. An example generated layout is shown in Figure 5–23.

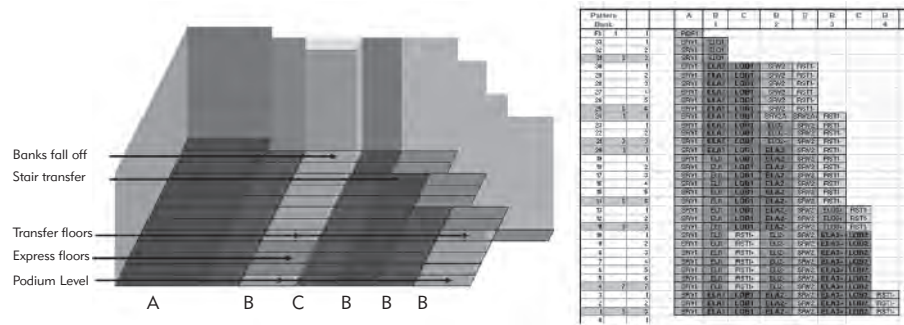
With this highly parameterized assembly, the high-rise tower could be defined in terms of its placement in an external shell and derived floor plates. Currently, the model is for towers with rectangular floor plates.

This example of embedded expertise in a custom parametric model can save days and weeks on a project and allows discussion with clients to develop detailed feasibility plans and assess them within a single meeting.



**FIGURE 5-23**

Basic module pattern and vertical logic. Express elevators and pass-through lobbies determine bathroom location and overall core layout. Special floors include podium-level and user-controlled elevator transfer floors. Example building and core, with texture mapped facade is presented.



*Building Object Models (BOMs)* are 2D and 3D geometric representations of physical products such as doors, windows, equipment, furniture, fixtures, and high-level assemblies of walls, roofs, ceilings, and floors at the various levels of detail needed, including specific products. For design firms involved in particular building types, parametric models of space types may also be represented in

libraries, for example, hospital operating suites or radiation treatment rooms, to enable their reuse across projects. These spatial and construction assemblies can also be considered as BOMs. Over time, the knowledge encoded in these model libraries will become a strategic asset. They will represent best practices, as design and engineering firms incrementally improve and annotate them with information based on project use and experiences. Building owners will develop object libraries that represent corporate standards for contractor-installed products and assemblies in their facilities. They will distribute these libraries to consulting A/E firms for project development, and use them to check/validate BIM designs received from A/E firms. These workflows involving object libraries will decrease the risk for errors and omissions, particularly as firms realize success in developing and using high-quality object models from previous projects.

It is anticipated that BOM libraries will reference useful information for a range of contexts and applications throughout the project delivery and facility maintenance lifecycle. Developing and managing BOMs introduces new challenges for AEC firms, because of the large number of objects, assemblies, and object families that firms must organize and distribute, possibly across multiple office locations.

### ***Object Definitions***

Here we outline the primary information content needs for advanced object specifications:

- 2D or 3D geometry (2D for carpeting, and film-like finishes)
- Material representation, with name and model graphical finish (texture map)
- Parametric geometry, if not fixed
- Connection locations and requirements with other systems: electrical, plumbing, telecommunications, structural, airflow
- Performance specifications, operating life, maintenance cycle, light transmittance, and other specs used in selection (varies by type of equipment)
- Luminous Intensity Distribution Curve (for light fixtures)
- Links to product distribution channels

These properties allow an object to be fully embedded into applications developing an advanced BIM model, then later for specific product selection.

A good beginning draft specification for this data is the Revit SEEK Metadata Style Guide (Autodesk 2009).

### **Organization and Access**

A review of current BIM design platforms shows that they have each defined and implemented a heterogeneous set of object types, using their own object families (see Table 2–1), some with predefined attribute fields. Library objects will need to be accessed and integrated into projects using the standard nomenclature defined within that BIM platform for proper interpretation. Full integration includes object classification, naming conventions, attribute structure, and possibly the designation of topological interfaces with other objects reflected in the rules used to parametrically define them. This enables the imported object to support interoperability and interfacing with such tools as cost estimation, system analysis, and eventually building code and building program assessment applications, among others. This may involve translation of objects to a common structure or defining a dynamic mapping capability that allows them to maintain their “native” terms but also allows them to be interpretable with synonym and hyponym relations.

The complexity and company investment required to develop BOM content emphasizes the need to plan and rely on library management tools for object management and distribution that allow users to organize, manage, find, visualize, and use BOM content.

Classification hierarchies, such as CSI MasterFormat® and UniFormat™, are useful indices for organizing and grouping BOMs into project models. For example, assigning CSI MasterFormat® codes to BOMs placed in projects can organize them for project specifications. Similarly, assigning UniFormat™ and Work Breakdown Structures (WBS) to BOMs can organize them for quantity takeoff, cost estimating, and construction planning. However, classification hierarchies are often inadequate for describing the configuration or application of a product or assembly for a specific project.

The OmniClass™ classifications developed by CSI are expected to provide more detailed object-specific classification and property definition structures (OmniClass™ 2007). CSI, in partnership with Construction Specifications Canada, BuildingSMART Norway, and STABU Foundation (Dutch) is implementing OmniClass™ terminology in the International Framework for Dictionaries (IFD) project, to establish a computer-interpretable representation of OmniClass™ product and property definitions that can serve as an object reference and validation tool for BIM objects in a project. Given these new indexing and classification tools for standardizing terminology for object names and properties, it will be possible to organize objects at an international scale for access and project



use. A well-designed library management system should support navigating multiple classifications to find object models, functionality to manage BOM libraries, including the ability to create catalogs of objects in a library (Library views) for specific projects or building types, and functionality for resolving discrepancies between object names and property sets across catalogs of objects.

### 5.4.3 BOM Portals

BOM portals serve as Web access points for building objects; both public and private portals have emerged in the marketplace. Public portals provide content and promote community through forums and indexes to resources, blogs, and the like. The content tools primarily support hierarchical navigation, search, download, and in some cases upload for BOM files. A comparison of the major portals is presented in Table 5–4. Private portals permit object sharing between firms and their peers that subscribe to joint sharing agreements under control of server access and management. Firms or groups of firms that understand the value in BOM content and the value/cost relation in different application areas may share BOMs or jointly support their development. Private portals enable firms to share common content and protect content that encodes specific, proprietary design knowledge.

Autodesk Seek aggregates content in multiple formats from partners, such as Reed Construction Data, and McGraw-Hill, ArCAT, CADdetails.com, and from end users. It provides fully parametric objects with topological connectivity for Revit®, for ADT, and to a lesser degree for SketchUp®; its data is formatted to meet the Autodesk Seek Metadata Style Guide. Seek's products can be uploaded and integrated with Revit models, including Autodesk Dragonfly, a Web-based home design program. It has partial consistency with OmniClass™ Table 23 and 49 Parts and Properties.

The Form Fonts EdgeServer™ product is an example of server technology that supports controlled sharing between peers. It supports SketchUp objects. ArchiBase Net is an ArchiCAD Web site with several thousand ArchiCAD objects. Most appear to be for visualization, without product specs or quality control. CadCells is a Microstation and Bentley Architectural cell site, the cells are developed by the proprietor of the site, and sold with a money-back guarantee. They contain only geometry without materials or properties.

The Google 3D Warehouse is a public repository for SketchUp content that represents building products and buildings. It permits anyone to create a segmented area of the warehouse and create a schema and classification hierarchy for library search. It offers free storage and other back-end services, the ability for a developer to link from a Web page to a model in 3D Warehouse, and thereby put up a *storefront* that uses 3D Warehouse as a back end. It also provides integration

**Table 5-4** Comparison Features of Public BOM Product Portals

Portals	Firm developed BOM	Public, Private, or Peer to Peer	Version Management	Navigation, Filters	Selection	BIM Authoring Tool Integration	BOM Modeling Guidelines	Ranking/ Annotation	Content Format	Web Site
Autodesk Seek	Syndication from contributors (RCD, McGraw-Hill, others) and user uploads	Public	No	By Revit® categories, by attribute	Yes	Query directly from Autodesk portfolio products (AutoCAD, Revit, Inventor). Supports I-drop interface for insertion from Seek to CAD system if data package published to Seek includes it.	Yes	No	Revit, AutoCAD, ®	<a href="http://seek.autodesk.com/">http://seek.autodesk.com/</a>
Revit City	No	Public	By Revit® software release	By CSI MasterFormat® 04, Revit city organization, keyword	Yes	No	No	Rating	Revit®	<a href="http://www.revitcity.com/downloads.php">www.revitcity.com/downloads.php</a>
ArchiBase Planet	No	Public, Peer to peer	No	Furnishings, equipment & appliances, doors & windows, structures, site improvement, people, kitchen, company lines	Yes	No	No	No	ArchiCAD®	<a href="http://www.archibase.net/">www.archibase.net/</a>
Autodesk Revit® User Group	No	Public	by Revit® software release	By Revit® category, Revit® release, unit of measure, manufacturer, author	Yes	No	No	No	Revit®	<a href="http://www.augi.com/revit.exchange/rpcviewer.asp">www.augi.com/revit.exchange/rpcviewer.asp</a>
CadCells	Yes	Private	No	By model application: architectural piping, HVAC, electrical	Yes	Microstation cell libraries come with a comprehensive pull-down menu to help locate and place a cell fast. AutoCAD block libraries are organized into logical folder structure for easy insertion.	No	No	Bentley cells, AutoCad 3D	<a href="http://www.cadcells.com/index.htm">www.cadcells.com/index.htm</a>

Objects Online	No	Public	No	By ObjectsOnline category Collections by product and room type	Yes	No	No	No	ArchiCAD®, AutoCAD®, and SketchUp, Vectorworks, Numerous rendering formats	www.objectsonline.com/customer/home.php
Google Warehouse	Yes	Public	No	Ability to create classification schema and add search tags	Yes	No	No	Rating	SketchUp	http://sketchup.google.com/3dwarehouse/
Form Fonts	Yes	Public, peer to peer	No	By CSI MasterFormat®, by keyword, platform, manufacturer	Yes	No	No	No	SketchUp, also AutoCAD®, Revit®, ArchiCAD®, 3DMax, Lightwave, Collada, Alias wavefront	www.formfonts.com
BIM Content Manager	Yes	Private	No	By Revit® category, folder, project, CSI MasterFormat®, UniFormat™, keyword, manufacturer	Yes	No	No	Yes	AutoCAD®, Revit®	www.digitalbuilding-solutions.com/
SmartBIM Library	Yes	Private	No	By Revit® category, MasterFormat®, user-defined tags, shared parameter properties	Yes	Launch from Revit. Drag-n-drop insert into Revit.	Yes	No	Revit®	http://smartbim.reedconstructiondata.com/
SmartBIM .com	No	Public	No	By Revit category and subcategory, and by building type and space type	Yes	No	No	No	Revit®	www.smartbim.com

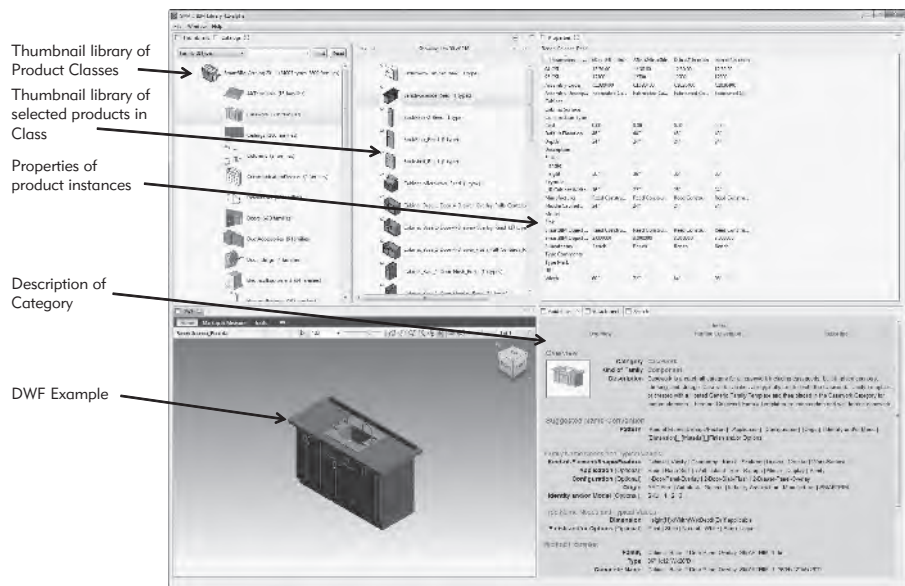
with Google Earth, so Google Earth serves as a location-based search tool for building models uploaded to 3D Warehouse. These capabilities are intended to create new business opportunities. For example, McGraw-Hill Sweets has experimented with 3D Warehouse by creating a McGraw-Hill Sweets' Group and placing Sweets-certified manufacturer BOM models in SketchUp format in the Warehouse. The potential is strong for combining Google-distributed service, search, semantic modeling, and storage technology with a business entity that has AEC-specific knowledge; however, a focused effort has not materialized.

### 5.4.4 Desktop/LAN Libraries

Private libraries are desktop software packages designed to distribute and manage building object content and closely integrate it with the user's file system. They automate the loading of BOMs into a standalone catalog in the library management system from a BIM tool, such as Revit®, or from the user's file system, or a corporate network. They provide a schema for classifying objects and defining property sets upon entry and used later for searches and inspection for retrieval. They assist searching, for example 3D visualization of objects outside the CAD system, inspection of categories, types, and property sets. The companies providing such tools also plan public portals for sharing BOMs across firms (file upload and download, community tools, and so forth) and distributing manufacturer-specific BOMs for building products.

One example of these products is the SmartBIM Library (SBL), shown in Figure 5–24. The products for various Revit® Families are in a catalog, which

**FIGURE 5–24**  
Multilevel structure of the SmartBIM Library.  
(Courtesy SMARTBIM LLC.)



a user can create from the file system or a Revit project. SBL displays multiple object catalogs, supports filtering across catalogs by object name, properties, user-defined tags, CSI MasterFormat®, UniFormat™, and OmniClass™ codes, and permits users to copy and move objects between user-defined catalogs. It also includes best practice guidelines for BOM modeling on the Revit® platform. Similar products include CAD Enhancement Inc.'s FAR Manager and BIM Manager. These companies are developing additional products based on these library capabilities.

---

## 5.5 CONSIDERATIONS IN ADOPTION FOR DESIGN PRACTICE

Moving the base representation of building design from a set of drawings, even if produced digitally, to a building model has many potential direct benefits: automatically consistent drawings; easy identification and removal of 3D spatial conflicts; automatic and potentially accurate preparation of bills-of-material; improved support for analysis, cost, and scheduling applications; as well as others. Three-dimensional modeling throughout the entire design process facilitates easily visualized coordination and design review; and these capabilities lead to more accurate design drawings, faster and more productive drawing production, and improved design quality.

### 5.5.1 BIM Justification

While BIM offers the potential to realize new benefits, these benefits are not free. The development of a 3D model, especially one that includes information that supports analyses and facilitates fabrication, involves more decisions and incorporates more effort than producing the current set of construction documents. Considering the inevitable additional costs of purchasing new systems, retraining staff, and developing new procedures, it is easy to rationalize that the benefits do not seem worthwhile. Most firms that have taken these steps, however, have found that the significant initial costs associated with the transition result in productivity benefits at the construction document level. Even the initial transition to producing consistent drawings from a model makes the transition worthwhile.

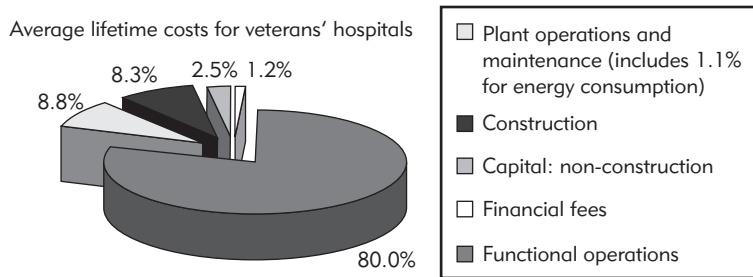
In the existing business structure of the construction industry, designers are usually paid a fee calculated as a percentage of construction cost. Success in a project is largely intangible, involving smoother execution and fewer problems, improved realization of design intent—and realizing a profit. With the

growing awareness of the capabilities offered by BIM technology and practices, building clients and contractors are exploring new business opportunities (see Chapters 4 and 6). Designers can begin to offer new services that can be added to the fee structure. These services can be grouped into two broad areas:

1. Concept design development, applying performance-based design using analysis applications and simulation tools to address:
  - Sustainability and energy efficiency
  - Cost and value assessment during design
  - Programmatic assessment using simulation of operations, such as in healthcare facilities
2. Integrating design with construction, related to project delivery contractual form:
  - Improved collaboration with the project team: structural, mechanical, electrical engineers, steel, MEP, precast and curtain wall fabricators. BIM use among a project team improves design review feedback, reduces errors, lowers contingency issues, and leads to faster construction.
  - Expedited construction, facilitating offsite fabrication of assemblies, reducing field work, and increasing safety.
  - Automation in procurement, fabrication, and assembly and early procurement of long lead-time items.

Comparing initial costs with operating costs is notoriously difficult, with varying discount rates, varied maintenance schedules, and poorly tracked costs. However, studies by Veterans Administration hospitals have found that less than eighteen months of functional operations of a VA hospital are equal to its construction costs, (see Figure 5–25) meaning that savings in hospital operations, even with higher first cost, can be hugely beneficial. The VA has also found that the lifetime fully amortized costs of energy are equal to one-eighth of construction costs and this percentage is likely to increase. In addition, the VA has found that fully discounted plant operating costs (including energy and building security) are roughly equal to construction costs. There are many other cost items available (see Department of Veteran Affairs, <http://www.cfm.va.gov/cost/>). These examples provide an indication of the reduction in operating costs and increases in performance that building owners/operators will be seeking.

The benefits of integrating BIM design with construction are already well articulated in Section 5.3.4.

**FIGURE 5-25**

The various components of the lifetime capital and operating costs of a veterans' hospital.

Image provided courtesy of Veteran's Administration (Smoot 2007).

### ***BIM Design Productivity Benefits***

One way to indirectly assess the production benefits of a technology such as BIM is according to the reduction of errors. These are easily tracked by the number of Requests for Information (RFIs) and Change Orders (COs) on a project. These will always include a component based on the client's change of mind or changes in external conditions. However, changes based on internal consistency and correctness can be distinguished and their numbers on different projects collected. These indicate an important benefit of BIM and have been reported in several of the case studies in Chapter 9.

Design firms are often not familiar with methods of assessing productivity of their organization. An initial step in making such an assessment is to establish a baseline for comparison. Few firms keep track of the unit costs associated with design development and construction drawing detailing, for example, based on building floor area, façade area, or project type. These can provide a baseline metric to evaluate the costs or benefits of a transition to new design technologies (such a method is described by Thomas et al. 1999).

The second step is to estimate the productivity gain of the new technology, in this case BIM. Apart from the productivity enhancement figures provided by various BIM vendors (Autodesk 2004), there is little data available within design firms that have already adopted BIM or even in available research literature. Research into the productivity gain for producing structural engineering drawings with rebar detailing has yielded gains between 21 and 59 percent, depending on the size, complexity, and repetitiveness of the structures (Sacks and Barak 2007). A few figures are also provided in the different case studies in Chapter 9. Of course, benefits for a particular design firm are necessarily speculative until real projects are undertaken. An assessment should distinguish time saved weighted according to the average wage of those doing the work and its percentage of the firm's annual labor cost. This will provide a weighted productivity gain. The resulting percentage can be multiplied by the annual direct labor costs for design activities to compute the annual benefit.

The third step is to estimate the increase in business that can be obtained through marketing the firm's BIM capabilities. These will vary by market but may be significant in some regions of the country.

The last step is to calculate the investment costs of adoption. The largest cost will be the labor cost of training time, which should include both direct costs for time spent and also the "learning curve cost" of initially reduced productivity as people learn to use the new tools. Hardware and software costs can be estimated in consultation with a BIM vendor. Productivity benefits will grow to their full extent over time. Finally, the total annual benefit divided by the total cost should provide a quick measure of the annual return on investment and the time needed to recoup the cost.

Section 2.3.1 provides guidelines for the selection of BIM tools. Modeling tools are not only for internal use. Another consideration is the needs of companies that are frequent design partners. Ideally, if there are certain dominant working relations, decisions should be made with some level of coordination.

A single BIM tool is not necessarily ideal. Some firms decide not to limit themselves to a single model generation tool, but rather to support multiple BIM products, recognizing that some tools have non-overlapping benefits.

### **5.5.2 Training and Deployment**

BIM is a new IT environment, requiring training, system configuration, library and document template setup, and adaptation of design review and approval procedures, often combined with new business practices. These need to be developed incrementally, side-by-side with existing production methods, so that learning problems do not jeopardize the completion of current projects.

We encourage preparation of a detailed deployment plan for any firm considering making a change to BIM; adoption should not be treated as an ad hoc activity. The more grounded the plan is in relation to a company's strategic goals, the more successful adoption is likely to be. The following sections address a range of issues to be considered in the deployment plan.

Training usually starts with one or a small number of IT specialists that both plan for system configurations and introduce a training program for the rest of the firm. System configuration includes hardware selection (BIM tools demand powerful workstation hardware), server setup, plotting and printing configurations, network access, integration with reporting and project accounting, setup of libraries (described in Section 5.4.1), and other company-specific system issues.

Early projects should focus on the basic skills needed for modeling buildings and producing drawings, including incremental definition of object libraries and getting the basics down before undertaking more advanced



integration efforts. After the basics of project management have been realized, the door is open to a variety of extensions for taking advantage of the multiple integration and interoperability benefits that BIM offers.

An important note of caution during the early phase of BIM adoption is to avoid providing too much model detail too soon. Because methods of project definition and detailing are partially automated in BIM, it is possible, if details are defined too quickly, for a design concept to be misinterpreted. Detailed models are easy to realize while still in the conceptual design phase but may lead to errors and client misunderstanding by inadvertently making overreaching decisions that become hard to reverse. It is important for BIM users to understand this issue and to manage the level of detailing more explicitly than would be done by hand. A reconsideration of the level of detail provided to consultants and collaborators has also been found to be worthwhile. These parties can be brought into discussions earlier or later, depending on their roles. Detailed MEP 3D layout should not be done until later in the process to avoid multiple revisions. On the other hand, curtain wall consultants and fabricators may be brought in earlier to help plan structural connections and detailing.

On larger projects, architects represent only one component of an overall design team. Collaboration requires engineering, mechanical, or other specialty consultants. The default initial integration arrangement is to rely on drawings in the conventional manner. Very quickly, however, the extra steps required for producing drawings leads to the desire for model-based exchanges. Procedures for coordination via model reviews and backed-up by data exchange methods must be worked out on a company-by-company basis. Model-based coordination using Web conferencing is a straightforward and very effective means of managing projects (see Section 5.3.2) and the case studies in Chapter 9.

### 5.5.3 Phased Utilization

In addition to external services discussed earlier, other services can be undertaken in almost any context. Among these are:

- Integration with cost estimation to allow continuous tracking throughout project development
- Integration with specifications for better information management
- Design level integration with performance analyses, for energy, air flows, lighting, to address issues only considered intuitively up to now
- Development of proprietary company libraries of detailing, room configurations, and other design information to facilitate the transfer of specialized staff knowledge to corporate knowledge

Each type of integration involves its own planning and development of workflows and methods. Taking a step-by-step approach will allow for incremental training and adoption of advanced services without undue risks, which will lead to radically new capabilities within the overall design firm.

---

## 5.6 NEW AND CHANGED STAFFING WITHIN DESIGN FIRMS

The greatest challenge in implementing new design technologies is the intellectual transition in getting senior design team leaders to adopt new practices. These senior staff, often partners, have decades of experience with clients, design development procedures, design and construction planning and scheduling, and project management that represent part of the core intellectual property within any successful firm. The challenge is to engage them in the transition in a way that enables them to realize both their own expertise and also the new capabilities that BIM offers.

Among the several potentially effective ways to address this challenge:

- Team partners with young BIM-savvy design staff who can integrate the partner's knowledge with the new technology.
- Provide one-on-one training one day a week or on a similar schedule.
- Host a charrette for design teams that includes training for partners in a relaxed offsite location.
- Visit firms that have made a transition to BIM, attend live seminars and Web-based seminars.

Similar transition issues exist with other senior staff, such as project managers and similar methods may be used to facilitate their transition. No method is guaranteed. The transition of a design organization is largely cultural. Through their actions, support, and expression of values, senior associates communicate their attitudes toward new technology to the junior members within the organization.

A second major challenge in any design firm will be the changed composition of staff with respect to skills. Because BIM most directly enhances productivity for design documentation, the proportion of hours spent on any project shifts away from construction documentation. Within a typical practice, a designer skilled in BIM can realize the intention and detailing of a project with much less outside drawing or modeling support than was previously required. Details, material selections, and layouts only need to be defined

**Table 5–5** Shifting Demand for Design Skills on a Typical Project

Professional Grade	Project Hours		Change
	Pre-BIM	Post-BIM	
Principal	32	32	0%
Project manager	128	192	33%
Project architect	192	320	40%
Architect I	320	192	–67%
Intern architect	320	96	–233%
Total	992	832	–19%

once and can be propagated to all drawings where they will eventually be visible. As a result, the number of junior staff members working on construction documentation will be reduced. A good example of the way in which the workload for a project is shifting in an architectural practice that has already adopted BIM can be seen in Table 5–5. This data was reported by a principal architect at a large design firm (Birx 2005). While the total labor hours are reduced, the total cost did not change substantially due to a shift toward a more experienced labor staff.

Although the need for entry-level architects is reduced, drawing cleanup, model detailing, and integration and coordination of multiple building subsystems will continue as important and valuable tasks.

BIM technology has new associated overhead costs beyond that of software investment. As firms already know, system management, often under the management of the Chief Information Officer (CIO), has become a crucial support function for most firms. IT dependency expands as it supports greater productivity in the same way that electricity has become a necessity for most kinds of work. BIM inevitably adds to that dependency.

As design firms adopt BIM, they will need to assign responsibility for the two much-expanded roles that will be crucial to their success:

- 1. Systems Integrator**—this function will be responsible for setting up exchange methods for BIM data with consultants inside and outside the firm. These are corporate- or enterprise-level responsibilities. It also involves setup of libraries (as described in Section 2.2.4) and templates for company use. The applications may be limited to a single set that are used in every project or a variable set that is selected according to the type of project and the consultants involved.

**2. Model Manager**—while the protocols for version control and managing releases are defined and well understood within the drawing document-based world (whether paper or virtual), options are different and more open-ended with BIM. There may be a single master model or a set of federated ones. Since models are accessible 24/7, releases can potentially be made multiple times a day. As a result, the potential for model corruption exists. Because a project model is a high-value corporate product, maintaining its data integrity justifies explicit management. The model manager determines the policies to be followed for establishing read-and-update privileges, for merging consultants' work, for coordinating work flows on a project-level basis, and for managing model consistency across versions.

Dealing with model review and releases and managing the consistency of models will require special attention until a set of conventions becomes standard. A model manager role must be assigned for each project.

## Chapter 5 Discussion Questions

---

1. Thinking about the level of information needed for cost estimation, scheduling, and purchasing, outline your recommendation regarding the level of detail that should be defined in a design model at the beginning of design development. How would it be different from concept design? Consider and recommend what the role of designers should be in supporting these activities.
2. Consider Case Studies 9-1, 9-6, 9-7 and 9-8, all of which present the work of architects and engineers. Then, identify a building designed with extensive use of BIM, and prepare a brief case study of your own. Review and report how the design was carried out, how information was shared among designers and between design and analysis applications, and what information was carried over for fabrication and construction. The stories of many buildings built with BIM can be found on the Web sites of the major BIM application vendors and of many design firms.
3. Consider any specific type of building system, such as hung ceiling systems, or an off-the-shelf curtain wall system.

For that system, identify how it could be supported by automation tools for its custom adaptation to a particular project. How could its fabrication be facilitated? Identify which levels of automation are practical today and which are not.

4. Obtain the recommended set of details for installing a manufactured door, window, or skylight. Examine and identify, using paper and pencil, the variations that might apply the detail. List these variations as a specification for what an automated parametric detailer needs to do and design a graphic user interface dialog for configuring the product.
5. Propose a new service for a design firm, based on the capabilities of BIM. Outline how the service would be of value to the owner. Also outline a fee structure and the logic behind that structure.
6. Conceptual design is often undertaken in such nontraditional BIM tools as form-Z or Maya. Lay out the alternative design development process utilizing one of these tools, in comparison to one of the new BIM tools. Assess the costs and benefits of both development paths.



# CHAPTER 6

---

## BIM for Contractors

---

### 6.0 EXECUTIVE SUMMARY

Utilizing BIM technology has major advantages for construction that save time and money. An accurate building model benefits all members of the project team. It allows for a smoother and better planned construction process that saves time and money and reduces the potential for errors and conflicts. This chapter explains how a contractor can obtain these benefits and what changes to construction processes are desirable.

Perhaps the most important point is that contractors must push for early involvement in construction projects, or seek out owners that require early participation. Contractors and owners should also include subcontractors and fabricators in their BIM efforts. The traditional design-bid-build approach limits the contractor's ability to contribute their knowledge to the project during the design phase, when they can add significant value. Integrated Project Delivery (IPD), where a joint contract requires that the architect, designers, general contractor, and key trade contractors work together from the start of a project, makes the best use of BIM as a collaborative tool.

While some of the potential value of a contractor's knowledge is lost after the design phase is complete, significant benefits to the contractor and the project team can still be realized by using a building model to support a variety of construction work processes. These benefits can ideally be achieved by developing a model in-house with the collaboration of subcontractors and fabricators; having a consultant develop a model is also possible.

The level of detail of the information in a building model depends on what functions it will be used for. For example, for accurate cost estimating, the model must be sufficiently detailed to provide the material quantities needed for cost evaluation. For 4D CAD schedule analysis, a less detailed model is adequate, but it must contain temporary works (scaffolding, excavation) and show how the construction will be phased (how deck pours will be made, the sequence of wall erection, and so forth).

One of the most important benefits is derived from close contractor coordination that can be achieved when all of the major subcontractors use the building model for detailing their portions of the work. This permits accurate clash detection and correction of clashes before they become problems in the field. The same reviews allow construction problems to be identified and solved in the most expeditious manner. Finally, it enables increased offsite prefabrication which reduces field cost and time and improves accuracy. Each of these uses of a building model is discussed in detail and examples are illustrated in the case studies in Chapter 9.

Any contractor contemplating the use of BIM technology should be aware that there is a significant learning curve. The transition from drawings to a building information model is not an easy one because almost every process and business relationship is subject to some change in order to exploit the opportunities offered by BIM. Clearly, it is important to plan these changes carefully and to obtain the assistance of consultants who can help guide the effort. At the end of the chapter we provide suggestions for making the transition and identify what problems can be anticipated.

In the absence of owner- or designer-driven BIM efforts, it is vital that contractors establish leadership in the BIM process if they are to gain the advantages for their own organization and better position themselves to benefit from industrywide BIM adoption.

---

## 6.1 INTRODUCTION

This chapter begins with a discussion of the various types of contractors and how BIM can provide benefits for their specific needs. It then goes into



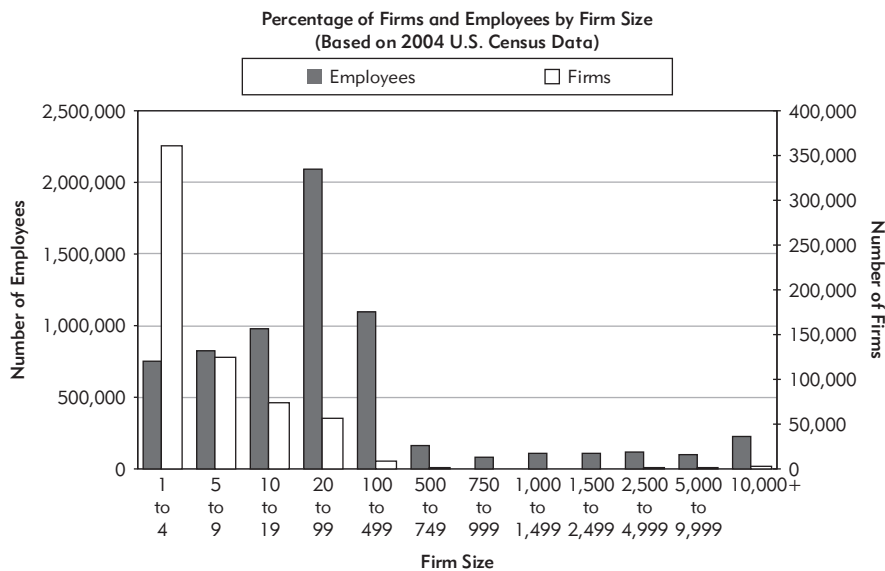
depth on important application areas that apply to most contractors. These include:

- Constructability analysis and clash detection
- Quantity takeoff and cost estimating
- Construction analysis and planning
- Integration with cost and schedule control and other management functions
- Offsite fabrication
- Verification, guidance, and tracking of construction activities
- Handover and commissioning

It follows with a discussion of the contractual and organizational changes that are needed to fully exploit the benefits that BIM offers. It concludes with some thoughts on how BIM can be implemented in a construction company.

## 6.2 TYPES OF CONSTRUCTION FIRMS

There is a tremendous range of construction companies, from large companies that operate in many countries and offer a wide range of services to small companies that have individual owners who work on one project at a time and provide a highly specialized service. There are far more of the latter (small-scale companies) than the former, and they perform a surprisingly large percentage of the total construction volume. Data for 2004 is shown in Figure 6–1.



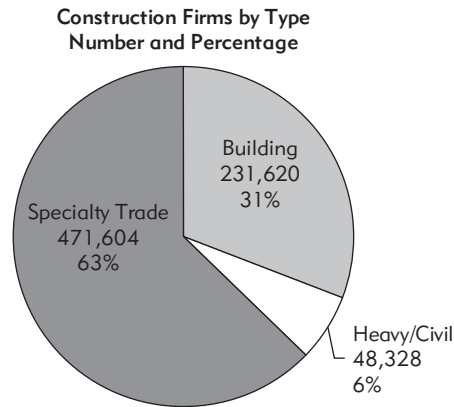
**FIGURE 6–1**  
Distribution of 751,098 construction firms and total employees by size of firm for 2004.

Source: U.S. Census Bureau, NAICS 23–Construction.

**FIGURE 6-2**

Percent of firms in each major construction sector, 2004.

Source: U.S. Census Bureau, NAICS 23—Construction.

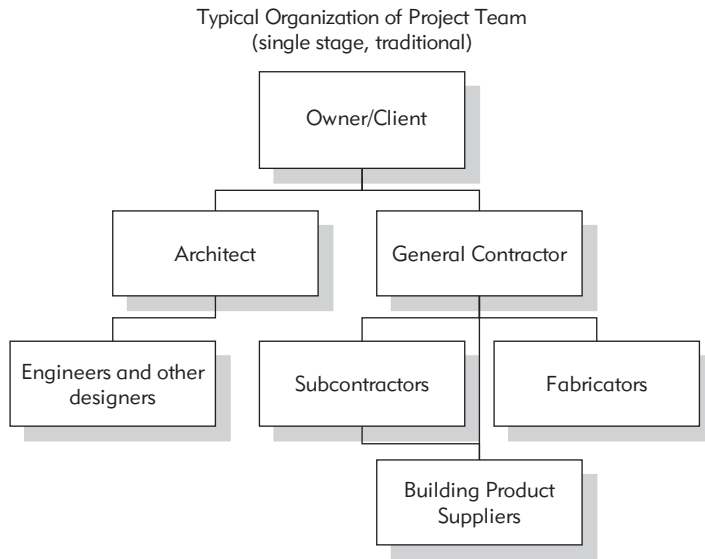


It shows that a large percentage of firms were composed of just 1 to 19 people (91.6 percent), but a majority of construction employees worked in firms larger than 19 people (61.6 percent). A very small percentage of firms (0.12 percent) had over 500 workers, and they employed 13.6 percent of the workforce. The average firm size was 9 employees.

When we look at the building industry, the range of contractors is also very large in terms of the services they offer. The bulk of the industry consists of contractors who start with a successful bid or a negotiated maximum price or fee, self-perform some of the work, and hire subcontractors for specialized services. Some contractors limit their service to managing the construction process. They hire subcontractors for all construction work. At the other end of the spectrum are design-build firms that take responsibility for both the design and construction processes but subcontract the bulk of the construction work. Almost all contractors end their responsibilities when construction is complete, but there are some that offer services in the turnover and management phases of the finished building (build-operate-maintain). Figure 6-2 shows the percentage of firms in each major sector of the construction industry in 2004. It shows that a majority of all firms fall in the specialty trade category (mainly small subcontractors).

Home builders differ from most other construction companies in that they act as developers: buying the land and applying for zoning changes, planning and constructing the infrastructure, and designing and building the homes that are sold. Home builders range in size from large public firms that build thousands of homes each year to individuals who build just one home at a time.

Fabricators of components produced offsite function as a hybrid between manufacturers and contractors. Some fabricators, such as precast concrete manufacturers, produce a range of standard products as well as



**FIGURE 6-3**  
Typical traditional organization of a project team for a building project.

custom items designed for a given project. Steel fabricators fall into the same category. A third group includes specialty fabricators that manufacture structural or decorative items from special steel, glass, wood, or other materials.

Finally, there are many types of subcontractors that specialize in one area or type of work, such as electrical, plumbing, or mechanical detailing. The general contractor selects these subcontractors based on competitive bids or they are preselected based on previous business relationships that have demonstrated effective collaboration. The specialized construction knowledge of these subcontractors can be very valuable during design, and many of them perform design review (also called design assist) as well as construction services. The percentage of work done by subcontractors varies widely depending on the type of work and contract relationship.

A typical project team organization is illustrated in Figure 6-3. There are many options for the organization of the project team. One is for the owner to hire a construction manager (CM), who then advises the owner or architect on the construction of the project but rarely assumes the risks associated with cost overruns.

The design-build (DB) firm is an important variation of the “typical” organization shown above (see Chapter 1, Section 1.1.2 for additional discussion of DB). The DB organization assumes responsibility for both design and construction. It serves as the single point of responsibility for nearly all problems associated with the project after an agreement has been reached on project scope and the total budget and schedule are established. The DB

model reduces risk for the client because it eliminates disputes associated with determining which firm is responsible for design errors or construction problems. The use of BIM in a DB firm can be very advantageous because early integration of the project team is possible and expertise is available for building the model and sharing it with all team members. This important advantage, however, cannot be achieved if the DB firm is organized along traditional disciplines and the designers work with 2D or 3D CAD tools that produce drawings or other documents that are merely handed-off to the construction group when the design is complete. In this case, much of the value that BIM brings to the project is lost, because the building model must be created after the design is complete. While this can still provide some value (see discussion following), it overlooks one of the major benefits of BIM for a construction organization—the ability to overcome the lack of true integration between design and construction. This lack of integration is the Achilles' heel of many projects.

---

### 6.3 INFORMATION CONTRACTORS WANT FROM BIM

Given the diversity of contractor types described above, it is not surprising that there is a wide range of processes and tools currently in use across the industry. Larger firms typically use computer-based systems for almost all of their key work processes, including: estimating, construction planning and scheduling, cost control, accounting, procurement, supplier and vendor management, marketing, and so forth. For tasks related to the design, such as estimating, coordination and scheduling, paper plans and specifications are the typical starting point, even if the architect used 2D or 3D CAD systems for the design. These require contractors to manually perform quantity takeoffs to produce an accurate estimate and schedule, which is a time-consuming, tedious, error-prone, and expensive process. For this reason, cost estimates, coordinated drawings, and detailed schedules are often not performed until late in the design process. Perhaps even more important, the contractor is not involved during the design process and is not able to offer suggestions that would reduce costs without sacrificing quality and sustainability.

Fortunately, this methodology is beginning to change, as contractors are recognizing the value of BIM for project team collaboration and construction management. By using BIM tools, architects are potentially able to provide models earlier in the procurement process that contractors can use for estimating, coordination, construction planning, fabrication, procurement, and other functions. At a minimum, the contractor can use this model to quickly add

detailed information. To permit these capabilities, ideally a building model would provide contractors with the following types of information:

- **Detailed building information** contained in an accurate 3D model that provides graphic views of a building's components comparable to that shown in typical construction drawings and with the ability to extract quantity and component property information.
- **Temporary components** to represent equipment, formwork, and other temporary components that are critical to the sequencing and planning of the project.
- **Specification information associated with each building component** with links to textual specifications for every component that the contractor must purchase or construct. This information is needed for procurement, installation, and commissioning.
- **Analysis data related to performance levels and project requirements** such as structural loads, connection reactions and maximum expected moments and shear, heating and cooling loads for tonnage of HVAC systems, targeted luminance levels, and the like. This data is for procurement, fabrication, and MEP detailing.
- **Design and construction status** of each component to track and validate the progress of components relative to design, procurement, installation, and testing (if relevant). This data is added to the model by the contractor.

No BIM tool or contract today comes close to requiring or satisfying this list of requirements, but this list serves to identify the information needs for future BIM implementations. Today, most BIM tools support the creation of information in the first and second items in the list. Even when project teams are formed from the beginning of a project, each participant might use different tools for creating their building model. Merging all the information in these models, other than graphic definitions needed for graphic model review, is often difficult. Thus, at the present time, creating a single model for all functions is not possible. Thus the need for interoperability using the methods described in Chapter 3, many of which are used in the case studies in Chapter 9.

An accurate, computable, and relatively complete building model that includes the above information is needed to support critical contractor work processes for estimating, coordinating trades and building systems, fabricating components offsite, and construction planning. It is important to note that each new work process often requires that the contractor add information to the model, since the architect or engineer would not traditionally include

means and methods information such as equipment or production rates, which are critical for estimating, scheduling, and procurement. Contractors use the building model to provide a base structure to extract information and will add construction-specific information as needed to support various construction work processes.

Additionally, if the scope of work for the contractor includes turnover or operations of the facility, links between BIM components and owner control systems, such as maintenance or facility management, will facilitate the commissioning and handover process to the owner at the end of the project. The building model needs to support representation of information related to all of these processes.

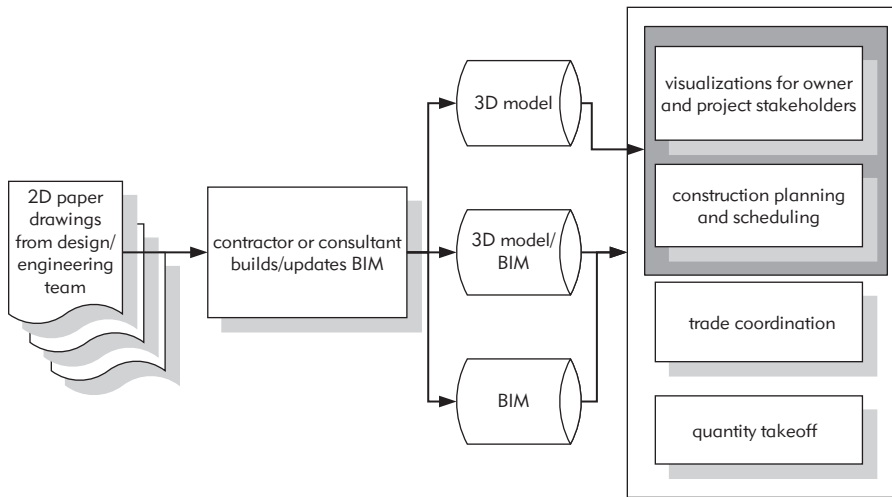
---

## 6.4 PROCESSES TO DEVELOP A CONTRACTOR BUILDING INFORMATION MODEL

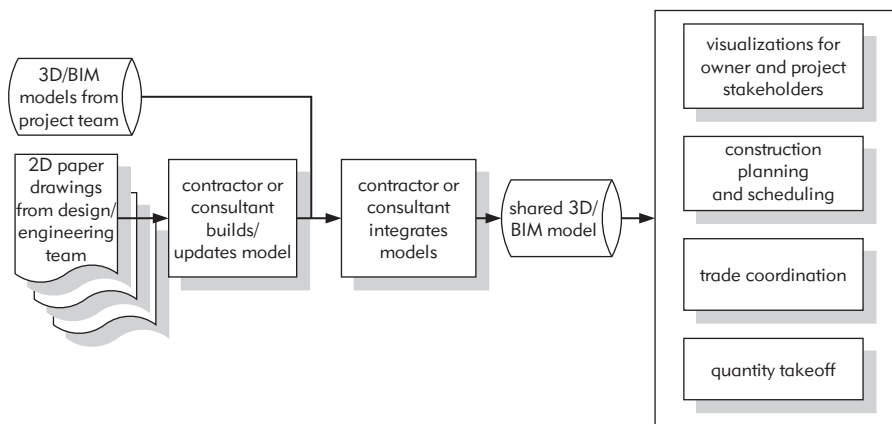
While use of BIM technology is increasing rapidly, it is in the early stages of broad implementation and contractors are using many different approaches to leverage this new technology. Often, when design teams have not created models for a project, contractors have taken ownership of the modeling process. Even when architectural use of BIM becomes commonplace, contractors will need to model additional components and add construction-specific information to make building models useful to them. Consequently, many leading-edge contractors are creating their own building models from scratch to support coordination, clash detection, estimating, 4D CAD, procurement, and so forth. Figure 6-4 shows a common workflow of a contractor creating a building information model from 2D paper drawings.

Note that, in some cases, the contractor is building a 3D model that is only a visual representation of the project. It does not contain parametric components or relations between them. In these cases, use of the model is limited to clash detection, constructability review, visualization, and visual planning, such as 4D, because the 3D model does not define discrete quantifiable components to support quantity takeoff or trade coordination. In other cases, contractors may build a hybrid 3D/parametric model that includes some BIM components, which enable some coordination and quantity takeoff. When contractors do produce a full building model, they can leverage it for multiple purposes.

Another approach for implementing BIM is illustrated in Figure 6-5. In this case, the project team collaborates on a model—3D, BIM, or hybrid—in an environment that is suited to their practice. Alternatively, if a specific organization works in 2D, the contractor or consultant can convert the 2D to

**FIGURE 6-4**

BIM process flow for a project where the contractor builds the construction model from 2D drawings and then uses it for quantity takeoff, construction planning, and clash detection.

**FIGURE 6-5**

Process flow for a project, where the architect and other designers and subcontractors use 3D modeling tools (or have a consultant develop a 3D model from 2D drawings) and contribute to a shared 3D model.

3D/BIM so that their work can be entered into the shared model. Typically, the contractor or the consultant manages the integration of these various models, which are developed independently by different members of the project team but then merged into a collaborative model. The shared model can be used by the project team for coordination, planning, quantity takeoff, and other functions. While this approach does not take advantage of all the tools that a full-featured building information model supports, it is thought to reduce costs and time compared to traditional practices. The shared 3D model becomes the basis for all construction activity and allows for much greater accuracy than 2D drawings. However, this approach does open the team to the risk that the shared model will not contain the most recent changes that have been made

outside the model (either in 2D or 3D in a separate model). This needs to be very carefully monitored to avoid errors, omissions, and (even more) rework.

As the practice and use of BIM increases, new processes will evolve. The case studies in Chapter 9 highlight a variety of ways in which contractors are adapting their work process to leverage BIM. The use of IPD is an example of a business process that has many advantages when BIM is properly used. In the following sections, we discuss specific modeling processes.

Home builders provide a good example of how a design-build effort can benefit from the use of BIM technology. When developing designs for model homes, a building information model can provide rapid feedback on the quantity and cost implications of a design change. When a buyer requests design modifications to a model home, this capability can provide fast visual and cost feedback and allow the prospective buyer to quickly reach an agreement with the builder. This kind of rapid response to clients' needs is of great value, especially for construction companies that provide customized building options based on systematic methods of construction.\*

---

## 6.5 REDUCTION OF DESIGN ERRORS USING CLASH DETECTION

A critical work process for any contractor is trade and system coordination. Using 2D drawings, clash detection is performed manually by overlaying individual system drawings on a light table to identify potential conflicts. Similarly, contractors use traditional 2D CAD tools to overlay CAD layers to visually and manually identify potential conflicts. These manual approaches are slow, costly, prone to error, and depend on the use of up-to-date drawings. To overcome these problems, some organizations use custom-written applications for automatically detecting clashes between drawing entities on different layers. Automatic detection of conflicts is an excellent method for identifying design errors, where objects either occupy the same space (a hard clash) or are too close (a soft clash) for adequate access, insulation, safety, maintenance, and so forth. In some publications, the term "clearance clash" is used instead of "soft clash." The terms are synonymous.

---

\*Three examples are the high-tech office buildings provided by the Beck Group, small-scale steel buildings provided by [www.butlermfg.com/steel\\_bld\\_ctr/](http://www.butlermfg.com/steel_bld_ctr/) or [www.steelbuildings.com](http://www.steelbuildings.com), and pre-cast parking structures designed, manufactured, and built by Finrock. Each of these companies has developed sophisticated BIM applications integrated with cost-estimating systems. The trend they represent, exploiting BIM to provide a competitive advantage by providing customized but yet "off-the-shelf" buildings, is discussed in Chapter 7.



BIM-based clash detection provides many advantages over traditional 2D coordination methods like overlays on a light table or simple automated 3D checks. Use of a light table is time consuming, error prone and requires that all drawings be current. 3D clash detection relies on 3D geometry models for identifying geometric entities often return a large number of meaningless clashes. Second, if the 3D geometries are not solids, the clash detection tool cannot detect clashes between objects within other objects. It can only detect clashes between surfaces. Furthermore, qualification of clashes into meaningful categories for the contractor is greatly inhibited due to lack of semantic information embedded in the 3D geometry models. A clash between surfaces could be a wall abutting a wall or a pipe running through a wall. The contractor has to verify and review each of these potential clashes.

In contrast, BIM-based clash detection tools allow automatic geometry-based clash detection to be combined with semantic and rule-based clash analysis for identifying qualified and structured clashes. BIM-based clash detection tools allow contractors to selectively check clashes between specified systems, such as checking for clashes between mechanical and structural systems, because each component in the model is associated with a specific type of system. Consequently, the clash detection process can be performed at any level of detail and across any number of building systems and trades. A BIM-based clash detection system can also use component classifications to more readily perform soft clash analyses. For example, the contractor can search for conditions in which the clearance or space between mechanical components and the subfloor is less than two feet. These types of clash detection analyses are only possible with well-defined and structured building models.

Regardless of the model's accuracy, the contractor must ensure that the building is modeled with an appropriate level of detail. It must have sufficient details for piping, ducts, structural steel (primary and secondary members) and attachments, and other components, so that clashes can be accurately detected. There are times when very small modeling errors cause clashes that would not be real problems during construction. These can easily be identified and ignored. However, if the detailing is inaccurate, a significant number of problems will not be found until the building is constructed, at which time they could be costly and time-consuming to resolve. Proper detailing of the model by subcontractors or other project team members responsible for the design of these systems is required. These subcontractors need to participate in the model development process as early as possible. Ideally, resolution would take place in a common project site office, where a large monitor can be used to display each problem area and each discipline can contribute their expertise to the solution. Agreed upon changes can then be entered into the

**FIGURE 6-6**

Snapshot of contractors and subcontractor using a building information model to support MEP coordination.

Courtesy of Swinerton, Inc.



appropriate design model prior to the next clash detection cycle. Experience has shown that there is no such thing as a minor change that does not require clash detection. Space conflicts are a significant source of construction site problems and can be largely eliminated with careful clash detection using an accurate and detailed model. Figure 6–6 shows a snapshot of two employees from the contractor and subcontractor using a building information model to support MEP coordination. This was done in a trailer at the jobsite. The case studies of the Sutter Medical Center in Castro Valley, California and of the Crusell Bridge in Finland, presented in Chapter 9, are good examples of early subcontractor participation in detailing a 3D model used for clash detection and other functions.

There are two predominant types of clash-detection technologies available in the marketplace: (1) clash detection within BIM design tools and (2) separate BIM integration tools that perform clash detection. All major BIM design tools include some clash-detection features that allow the designer to check for clashes during the design phase. But the contractor often needs to integrate these models and may or may not be able to do so successfully within the BIM authoring tool due to poor interoperability or the number and complexity of objects.

The second class of clash-detection technologies can be found in BIM integration tools. These tools allow users to import 3D models from a wide variety

of modeling applications and visualize the integrated model. Examples of this are Autodesk's Navisworks Manage package (Navisworks 2008) and Solibri Model Checker v6 (Solibri 2010). The clash-detection analyses that these tools provide tend to be more sophisticated, and they are capable of identifying more types of soft and hard clashes. The drawback is that identified clashes cannot be fixed immediately because the integrated model is not directly associated with the original model. In other words, the information flow is one way and not bidirectional. An exception to this statement is the Solibri Model Checker and Issue Locator which has been extended and made publicly available as the OpenBIM Collaboration Format. This XML format allows feedback from clash detection or other issue identifying application in the originating building model to communicate to Architectural Desktop (from Autodesk), Tekla, and ArchiCAD (from Graphisoft) that identifies issues and action items, and provides a camera location for viewing. Revit and Digital Projects and Bentley have made commitments to support this new cross-platform communication method. These capabilities must be introduced into the originating systems or upstream modeling tools and also the receiving, downstream models. This new capability can be used to potentially provide two-way communication for any pair of clash detection or rule-checking tools, as part of a design tool or standalone checking tool.

---

## 6.6 QUANTITY TAKEOFF AND COST ESTIMATING

There are many types of estimates that can be developed during the design process. These range from approximate values early in the design to more precise values after the design is complete. Clearly, it is undesirable to wait until the end of the design phase to develop a cost estimate. If the project is over budget after the design is complete, there are only two options: cancel the project or apply value engineering to cut costs and possibly quality. As the design progresses, interim estimates help to identify problems early so that alternatives can be considered. This process allows the designer and owner to make more informed decisions, resulting in higher quality construction that meets cost constraints. BIM greatly facilitates the development of interim estimates.

During the early design phase, the only quantities available for estimating are those associated with areas and volumes, such as types of space, perimeter lengths, and so forth. These quantities might be adequate for what is called a *parametric cost estimate*, which is calculated based on major building parameters. The parameters used depend on the building type, for example, number of parking spaces and floors for a parking garage, number and area of each

type of commercial space, number of floors, quality level of materials for a commercial building, location of building, number of elevators, external walls area, roof area, and the like. Unfortunately these quantities are not generally available in early schematic design because they do not define object types, such as those created by a BIM design system. Therefore, it is important to move the early design model into BIM software to allow for quantity extractions and approximate cost estimates. An example of this type of system is the DProfiler modeling and estimating system from Beck Technology (see additional description of this system in Chapter 4).

As the design matures, it is possible to rapidly extract more detailed spatial and material quantities directly from the building model. All BIM tools provide capabilities for extracting counts of components, area and volume of spaces, material quantities, and to report these in various schedules. These quantities are more than adequate for producing approximate cost estimates. For more accurate cost estimates prepared by contractors, problems may arise when the definitions of components (typically assemblies of parts) are not properly defined and are not capable of extracting the quantities needed for cost estimating. For example, BIM software might provide the linear feet of concrete footings but not the quantity of reinforcing steel embedded in the concrete; or the area of interior partition walls but not the quantity of studs in the walls. These are problems that can be addressed, but the approach depends on the specific BIM tool and associated estimating system. If an IPD approach is being used that allows the general and trade contractors to participate during the design process, then accurate cost estimates can be developed earlier in the design. In addition, contractor knowledge of constructability can inform the design process and help to reduce model revisions and thus cost and time.

It should be noted that while building models provide adequate measurements for quantity takeoffs, they are not a replacement for estimating. Estimators perform a critical role in the building process far beyond that of extracting counts and measurements. The process of estimating involves assessing conditions in the project that impact cost, such as unusual wall conditions, unique assemblies, and difficult access conditions. Automatic identification of these conditions by any BIM tool is not yet feasible. Estimators should consider using BIM technology to facilitate the laborious task of quantity takeoff and to quickly visualize, identify, and assess conditions, and provide more time for constructability reviews and to optimize prices from subcontractors and suppliers. A detailed building model is a risk-mitigation tool for estimators that can significantly reduce bid costs, because it reduces the uncertainty associated with material quantities. The One Island East Office Tower and the Sutter Medical Center case studies in Chapter 9 provide excellent examples of this.

Estimators use a variety of options to leverage BIM for quantity takeoff and to support the estimating process. No BIM tool provides the full capabilities of a spreadsheet or estimating package, so estimators must identify a method that works best for their specific estimating process. Three primary options are:

1. Export building object quantities to estimating software
2. Link the BIM tool directly to the estimating software
3. Use a BIM quantity takeoff tool

Each of these options is discussed in detail below.

### **6.6.1 Export Quantities to Estimating Software**

As previously noted, most BIM tools offered by software vendors include features for extracting and quantifying BIM component properties. These features also include tools to export quantity data to a spreadsheet or an external database. In the United States alone, there are over 100 commercial estimating packages and many are specific to the type of work estimated. However, surveys have shown that MS Excel is the most commonly used estimating tool (Sawyer and Grogan 2002). For many estimators, the capability to extract and associate quantity takeoff data using custom Excel spreadsheets is often sufficient. This approach, however, may require significant setup and adoption of a standardized modeling process. To go beyond the use of Excel, one of the following processes is required.

### **6.6.2 Directly Link BIM Components to Estimating Software**

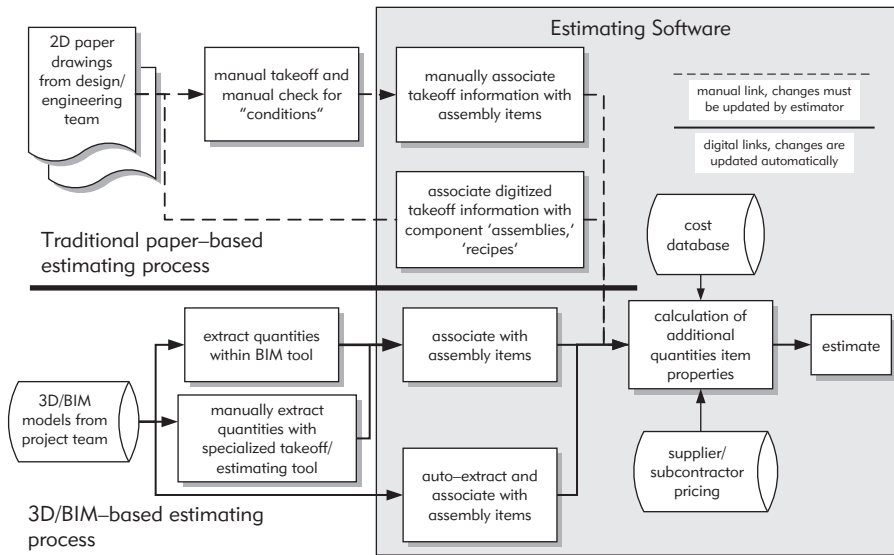
The second alternative is to use a BIM tool that is capable of linking directly to an estimating package via a plug-in or third-party tool. Many of the larger estimating software packages now offer plug-ins to various BIM tools. These include: Sage Timberline via Innovaya (Innovaya 2010); U.S. Cost (Success Design Exchange 2010, Success Estimator 2010); Nomitech (CostOS v3.6 BIM Estimating 2010); and Vico Estimator (Vico 2010). These tools allow the estimator to associate objects in a building model directly with assemblies, recipes, or items in the estimating package or with an external cost database such as R.S. Means. These assemblies or recipes define what steps and resources are needed for construction of the components onsite or for the erection or installation of prefabricated components. Assemblies or recipes often include references to the activities needed for the construction, for example, place forms, place rebar, place concrete, cure, and strip forms. The estimator is able to use rules to

calculate quantities for these items based on the component properties or manually enter data not extracted from the building information model. The assemblies may also include items representing necessary resources such as labor, equipment, materials, and so forth and associated time and cost expenditures. As a result, all information required to develop a complete cost estimate and detailed list of basic activities can be used for construction planning. If this information is related to the BIM components, it can be used to generate a 4D model. The graphic model can also be linked to the estimate to illustrate the model objects associated with each line item within that estimate. This is very helpful for spotting objects that have no cost estimate associated with them. This approach works well for contractors who have standardized on a specific estimating package and BIM tool. Integrating BIM component information from subcontractors and various trades, however, may be difficult to manage if different BIM tools are used. There are clear benefits to this highly integrated approach, but one potential shortcoming is the need for the contractor to develop a separate model. Of course, if the architect is not using BIM, then a contractor model is a necessity. When this is not the case, it is more efficient for the designer's model to provide the starting point for the contractor once the team has agreed on component definitions. If the project team is standardized on a single software vendor platform, this method may be suitable. This requires either a design-build approach or a contract that integrates the main project participants from the beginning of the project (IPD). Once again, early integration and collaboration are the keys to effective use of BIM technology. The *AGC BIM Guidelines for Contractors* emphasizes this point (see discussion in Section 6.8).

### 6.6.3 Use a Quantity Takeoff Tool

A third alternative, shown generically in Figure 6–7, is to use a specialized quantity takeoff tool that imports data from various BIM tools. This allows estimators to use a takeoff tool specifically designed for their needs without having to learn all of the features contained within a given BIM tool. Examples of these are: Autodesk QTO (QTO 2010), Exactal CostX® Version 3.01 (Exactal 2009), Innovaya (Innovaya 2010), and Vico Takeoff Manager (Vico 2010). These tools typically include specific features that link directly to items and assemblies, annotate the model for “conditions,” and create visual takeoff diagrams. These tools offer varying levels of support for automated extraction and manual takeoff features. Estimators will need to use a combination of both manual tools and automatic features to support the wide range of takeoff and condition checking they need to perform.

Changes to the building model require that any new objects be linked to proper estimating tasks so that accurate cost estimates can be obtained from the building model, depending on the accuracy and level of detail already



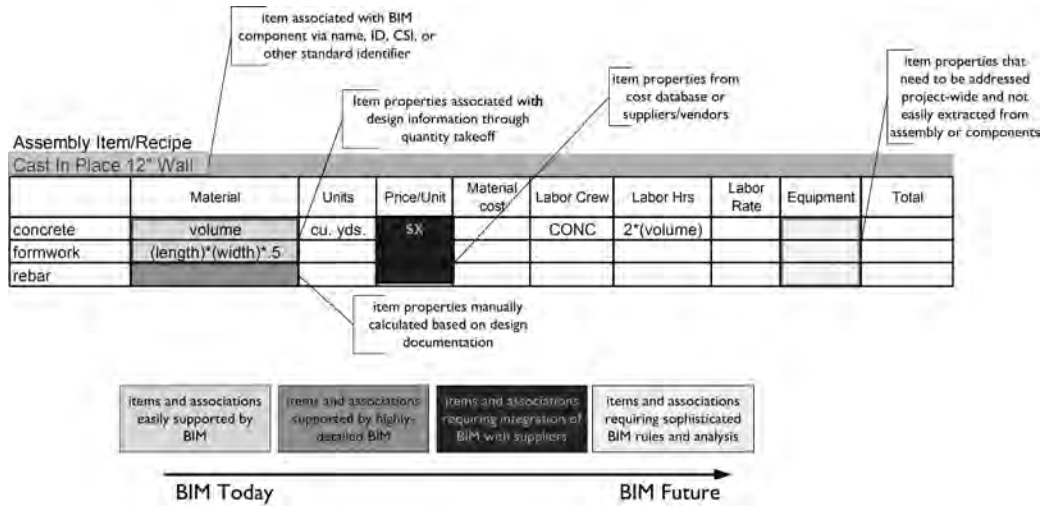
**FIGURE 6-7**  
Conceptual diagram of a  
BIM quantity takeoff and  
estimating process.

modeled. The Innovaya system provides a visual model of all the objects that have been imported from the BIM model and highlights in color those objects that have been changed since the last time the building was estimated. It also highlights those objects that have not been included in the cost estimate.

#### 6.6.4 Guidelines and BIM Implementation Issues to Support Quantity Takeoff and Estimating

Estimators and contractors should understand how BIM can support specific estimating tasks by reducing errors and improving accuracy and reliability within the estimate. More importantly, they can benefit from the ability to respond rapidly to changes during critical phases of the project, a challenge many estimators face on a daily basis. There is a good discussion of model-based estimating in the Sutter Medical Center case study in Chapter 9. It describes the process used for extracting quantities from various models and then making cost estimates from these quantities. There were many difficulties that had to be overcome and expert assistance was needed to make it possible. Here are some guidelines to consider:

- ***BIM is only a starting point*** for estimating. No tool can deliver a full estimate automatically from a building model. Figure 6-8 illustrates that a building model can provide only a small part of the information needed for a cost estimate (material quantities and assembly names). The remaining data comes either from rules or manual entries provided by a cost estimator.



**FIGURE 6-8** Example of how BIM component definitions relate to estimating assembly items and recipes.

It's important to note that BIM provides only a subset of the information estimators need to compute cost, and BIM components provide takeoff information but often lack the detailed capability of automatically computing labor, job (nonpermanent) material, and equipment costs.

- **Start simple.** If you are estimating with traditional and manual processes, first move to digitizers or on-screen takeoff to adjust to digital takeoff methods. As estimators gain confidence and comfort with digital takeoff methods, consider moving to a BIM-based takeoff.
- **Start by counting.** The easiest place to start is use BIM to support quantity takeoff and estimating for the tasks that involve counting, such as doors, windows, and plumbing fixtures. Many BIM tools provide scheduling functionality and simple functions to query and count specific types of components, blocks, or other entities. These can also be verified and validated.
- **Start in one tool, and then move to an integrative process.** It's easiest to start by doing takeoff in the BIM software or a specialized takeoff application. This limits potential errors or issues with respect to translating data and moving model data from one application to another. Once the estimator is confident that the data provided by a single software package is accurate and valid, then the model's data can be transferred to a secondary takeoff tool for validation.
- **Set explicit level of detail expectations.** The level of detail in the BIM takeoff is a reflection of the level of detail in the overall building model. If rebar isn't included in the building model, these values won't be auto-calculated. The estimator needs to understand the scope of the model information and what is represented.



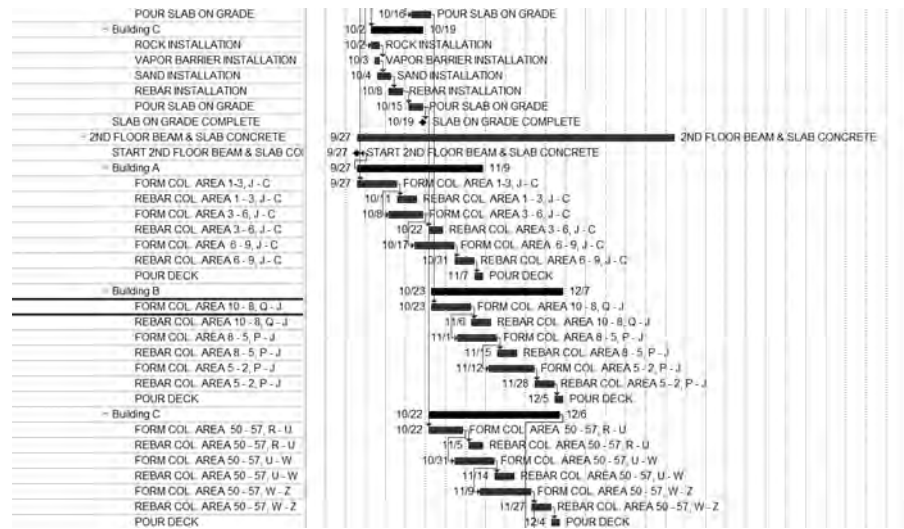
- ***Start with a single trade or component type*** and work out the kinks.
- ***Automation begins with standardization.*** To fully leverage BIM, designers and estimators will need to coordinate methods to standardize building components and the attributes associated with those components for quantity takeoff. In addition, in order to generate accurate quantities of subcomponents and assemblies, such as the studs inside a wall, it is necessary to develop standards for these assemblies. It may be necessary to modify the object definitions in the BIM system you are using to correctly capture the quantities needed for cost estimating, for example, the object might not provide linear feet of taping needed for installing sheetrock wallboard.

---

## 6.7 CONSTRUCTION ANALYSIS AND PLANNING

Construction planning and scheduling involves sequencing activities in space and time, considering procurement, resources, spatial constraints, and other concerns in the process. Traditionally, bar charts were used to plan projects but were unable to show how or why certain activities were linked in a given sequence; nor could they calculate the longest (critical) path to complete a project. Today, schedulers typically use Critical Path Method (CPM) scheduling software such as Microsoft Project, Primavera SureTrak, or P3 to create, update, and communicate the schedule using a wide variety of reports and displays. These systems show how activities are linked and allow for the calculation of critical path(s) and float values that improve scheduling during a project. Specialized software packages that are better suited to building construction, such as Vico Control 2009, enable schedulers to do location-based scheduling that helps to schedule crews doing repetitive work in multiple locations. Sophisticated planning methods for resource-based analysis, including resource-leveling and scheduling with consideration of uncertainty, such as Monte Carlo simulation, are also available in some of the packages. Other software tools are available for detailed schedules for short time periods of one or two weeks that consider individual subs, material availability, and so forth.

Traditional methods, however, do not adequately capture the spatial components related to these activities, nor do they link directly to the design or building model. Scheduling is therefore a manually intensive task, and it often remains out of sync with the design and creates difficulties for project stakeholders to easily understand the schedule and its impact on site logistics. Figure 6–9 shows a traditional Gantt chart which illustrates how difficult it is to evaluate the construction implications of this type of schedule display.



**FIGURE 6-9** Sample Gantt chart of a construction schedule for a project involving three buildings and multiple floors and areas.

Assessing the feasibility or quality of a schedule based on a Gantt chart is often difficult for many project participants and requires manually associating each activity with areas or components in the project since there are no visual associations with the referenced areas, such as “Area 10” to a drawing or diagram.

Only people thoroughly familiar with the project and how it will be constructed can determine whether this schedule is feasible. Two types of technologies have evolved to address these shortcomings.

The first is 4D CAD, which refers to 3D models that also contain time associations. The construction schedule is linked to the 3D model, allowing visualization of the sequential construction of the building. 4D CAD tools allow schedulers to visually plan and communicate activities in the context of space and time. 4D animations are movies or virtual simulations of the schedule.

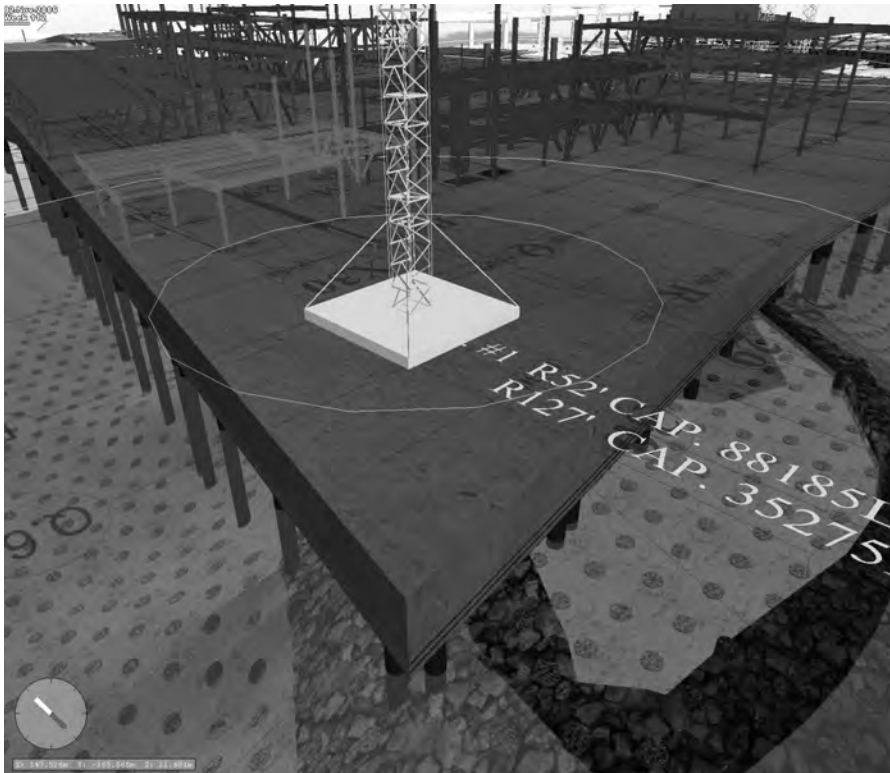
The second approach is to use analysis tools that incorporate BIM components and construction method information to optimize activity sequencing. These tools incorporate spatial, resource utilization, and productivity information. These two approaches are discussed in the following sections.

A third approach is becoming more popular as part of Lean construction practices. It is termed “pull driven” scheduling, and its main principles include preparation of a workable backlog of tasks and selection of tasks from the backlog for assignment to teams for execution only if and when they are mature for execution. In practice, this often implies that work teams assume assignments only when all conditions are fulfilled, essentially delaying tasks

until the “last responsible moment.” This approach to detail level (the next one to three weeks) scheduling is in fact production control, and the technique is called the Last Planner System™ (Ballard 2000). It can be supported by BIM in numerous ways, especially through visualization of the construction process.

### 6.7.1 4D models to support construction planning

4D models and tools were initially developed in the late 1980s by large organizations involved in constructing complex infrastructure, power, and process projects in which schedule delays or errors impacted cost. As the AEC industry adopted 3D tools, construction organizations built manual 4D models and combined snapshots of each phase or period of time in the project. Custom and commercial tools evolved in the mid- to late 1990s, facilitating the process by manually creating 4D models with automatic links to 3D geometry, entities, or groups of entities for construction activities (see Figures 6–10, 6–11, and 6–12). BIM allows schedulers to create, review, and edit 4D models more frequently, which has led to the implementation of better and more reliable schedules. The following sections discuss the benefits of 4D models and the various options schedulers have when producing them.

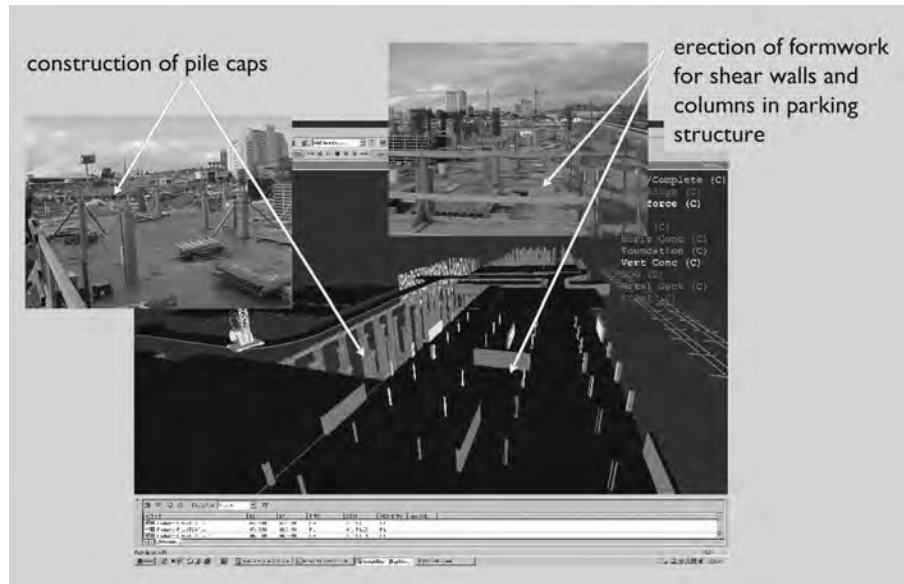


**FIGURE 6–10**

4D view of construction of Vancouver Convention Center showing foundation and structural steel erection.

A tower crane was included in the model to review crane reach, clearances, and conflicts.

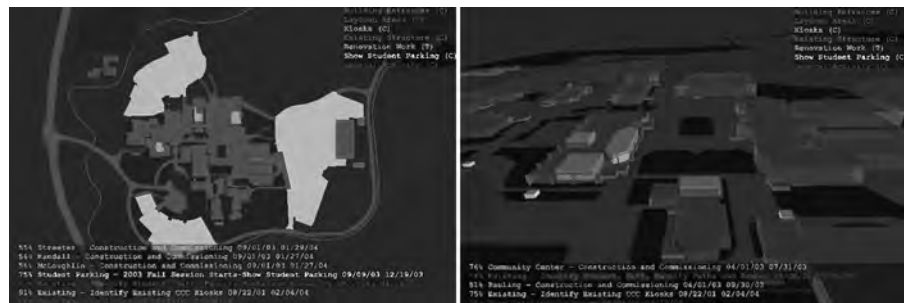
Courtesy Pacific Project Systems Inc., MTC Design/3D, (4D modeling); Musson Cattell Mackey Partnership, Downs/Archambault & Partners, LMN Architects (architects); Glotman Simpson Consulting Engineers (structural engineers); PCL Constructors Westcoast Inc. (CM) (See color insert for full color figure.)



**FIGURE 6-11** A snapshot of a 4D model and photos from the project site.

The project team used the model to support zone management and plan concurrent activities of foundation and concrete work. While a 4D model supports communication of sequencing of such work, the model did not include formwork and other temporary components which do impact the ability to perform work in the field.

Courtesy of DPR Construction.



**FIGURE 6-12** 4D snapshots of a campus-wide project showing various construction activities occurring throughout the campus to landscape, road, and facilities.

These images help a contractor to communicate with the owner and the campus community about impacts to parking, roads, and access to specific buildings.

Courtesy of DPR Construction.

### 6.7.2 Benefits of 4D Models

4D CAD tools allow the contractor to simulate and evaluate the planned construction sequence and share it with others in the project team. Objects in the building model should be grouped according to the phases of construction and linked to appropriate activities in a project schedule. For example, if a concrete deck will be placed in three pours, then the deck must be detailed into three sections so that this sequence can be planned and illustrated. This applies to all objects needed for these three pours: concrete, steel, embeds, and the like. In addition, the excavation areas and temporary structures such as scaffolding and lay-down areas should be included in the model. This is a key reason why contractor knowledge is beneficial when defining a building model. If the model is built by the architect or the contractor while the building is still being designed, the contractor can provide rapid feedback regarding constructability, sequencing, and estimated construction cost. Early integration of this information is of great benefit to the architect and owner.

4D simulations function primarily as communication tools for revealing potential bottlenecks and as a method for improving collaboration. Contractors can review 4D simulations to ensure that the plan is feasible and as efficient as possible. The benefits of 4D models are:

- **Communication:** Planners can visually communicate the planned construction process to all project stakeholders. The 4D model captures both the temporal and spatial aspects of a schedule and communicates this schedule more effectively than a traditional Gantt chart.
- **Multiple stakeholder input:** 4D models are often used in community forums to present to laypersons how a project might impact traffic, access to a hospital, or other critical community concerns.
- **Site logistics:** Planners can manage laydown areas, access to and within the site, location of large equipment, trailers, and so forth.
- **Trade coordination:** Planners can coordinate the expected time and space flow of trades on the site as well as the coordination of work in small spaces.
- **Compare schedules and track construction progress:** Project managers can compare different schedules easily, and they can quickly identify whether the project is on track or behind schedule.

Above all, 4D CAD requires that an appropriate 3D model of the building be linked to a project schedule that, in turn, provides start and end dates and floats for each object. There are a number of systems that provide these linkage capabilities.

The above considerations make the use of 4D CAD a relatively expensive process to set up and manage during a project. Prior experience and knowledge of the level of detail needed to produce an accurate linked schedule are necessary to achieve the full benefits associated with this tool. When used properly, however, the associated cost and time benefits have been found to far exceed the initial implementation cost. For a good example, see the One Island East project case study in Chapter 9. On this project a detailed 4D CAD analysis of the construction steps required for each floor was done to find potential problems. This allowed the contractor to ensure that a construction cycle of four days per floor could be safely maintained.

### **6.7.3 4D Modeling Processes**

Similar to the options estimators have, schedulers can choose from a variety of tools and processes to build 4D models:

1. Manual method using 3D or 2D tools
2. Built-in 4D features in a 3D or BIM tool
3. Export 3D/BIM to 4D tool and import schedule

#### ***Manual, CAD-Based Methods***

Construction planners have been building 4D models manually for decades using colored pencils and drawings, with different colors for different sequences to show the progression of work over time. With the advent of CAD, planners transferred this process to CAD drawings that use colored-fills, shading, and the ability to turn CAD entities on and off. In some cases, where the model included naming conventions or component attributes related to the construction schedule, the process could be automated. In most cases, planners worked with a third party to create high-end movies or rendered animations to visually demonstrate the schedule. These animations are visually appealing and a great marketing tool, but they are not adequate planning or scheduling tools. Because they are produced manually, it remains difficult to change, update, or do real-time scenario planning. When the schedule's details change, the planner must resynchronize the 4D image manually with the schedule and create a new set of snapshots or animations. Because of these manual update requirements, the use of these tools is normally limited to the initial stages of design when visualization of the construction process is desired for the client or some outside agency.

#### ***BIM Tools with 4D Capability***

One way to generate 4D snapshots is through features that automate filtering of objects in a view based on an object property or parameter. For example, in

Revit each object can be assigned to a “phase” that is entered as text, such as “June 07” or “existing” and order these phases as desired. Users can then apply filters to show all objects in a specified phase or previous phases. This type of 4D functionality is relevant for basic phasing and generation of 4D snapshots but does not provide direct integration with schedule data. Additionally, features to interactively play back a 4D model common in specialized 4D tools are not provided. Tekla Structures, on the other hand, features a built-in scheduling interface, providing multiple links between physical objects and task objects in the model. A given physical object can link to one or more tasks and a given task can link to one or more physical objects. Models can be used for 4D evaluations of construction sequences, with appearance and disappearance of temporary facilities. Model objects can also be color-coded based on time-dependent attributes. The use of these capabilities is explained in the Crusell Bridge case study in Chapter 9.

Most BIM tools, however, don’t have built-in “date” or “time” capabilities, and require specific 4D modules or add-on tools to directly link to schedule data. Table 6–1 provides a brief overview of both built-in 4D features and add-on 4D functionality available for the popular BIM tools.

Due to the shortcomings inherent in manual and CAD/BIM-based 4D modeling tools, several software vendors began offering specialized tools for producing 4D models from 3D models and schedules. These tools facilitate the production and editing of 4D models and provide the scheduler with numerous features for customizing and automating production of the 4D model. Typically, these tools require that data from a 3D model be imported from a CAD or BIM application. In most cases, the extracted data is limited to geometry and a minimal set of entity or component properties, such as “name,” “color,” and a group or hierarchy level. The scheduler imports relevant data into the 4D tool, then “links” these components to construction activities, and associates them with types or visual behaviors. Figure 6–13 illustrates two approaches to creating the 4D model. The top part shows how a series of snapshots of the construction process can be created from 2D drawings. The lower portion illustrates how a true 4D model can be created from a 3D model linked to a construction schedule using specialized 4D software. Figure 6–14 shows the types of datasets that are used by 4D software to generate the 4D model.

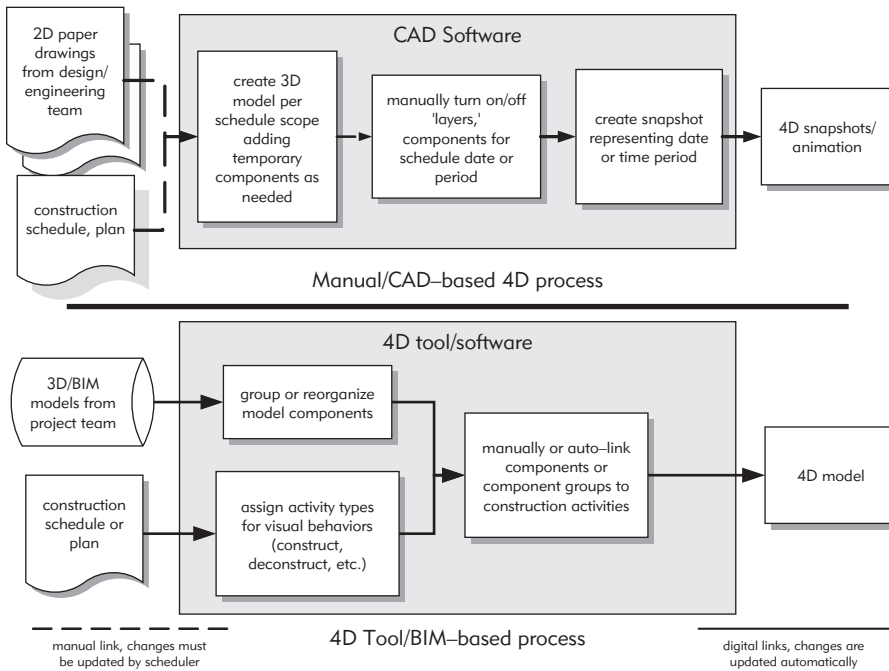
Here are some things to consider when evaluating specialized 4D tools listed in Table 6–1:

- **BIM import capabilities:** What geometry or BIM formats can users import and what types of object data can the tool import, for example, geometry, names, unique identifiers, and the like? In some cases the

**Table 6-1** Selected BIM Tools with 4D Capability

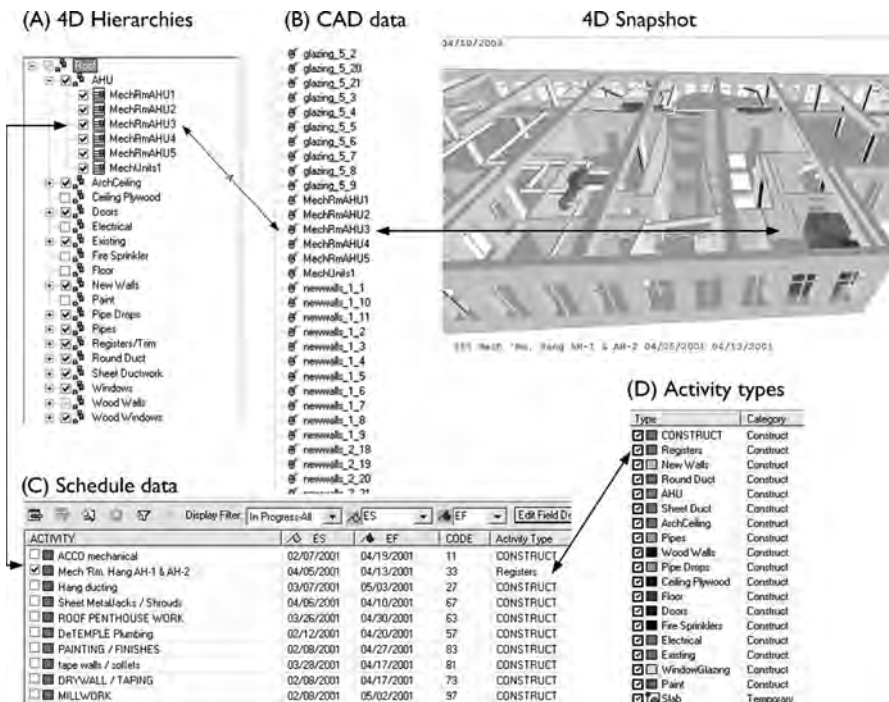
Company	Product	Remarks
Autodesk	Revit Architecture	Each Revit object includes parameters for “phasing” that allow users to assign a “phase” to an object and then use Revit’s view properties to view different phases and create 4D snapshots. It is not possible to play back a model, however. Via the API, users can link to scheduling applications and exchange data with tools like MS Project to automate some 4D entry.
Tekla	Tekla Structures	A full-fledged Gantt chart scheduling interface allows definition of tasks and association of model objects to one or more tasks. The model can be played between dates and objects can be color-coded according to time-dependent attributes.
Gehry Technologies	Digital Project	An add-on product, Construction Planning and Coordination, allows users to link 3D components to Primavera or MS Project activities with their associated data and generate 4D simulation analysis. Construction-related objects need to be added (and removed when appropriate) to DP model. Changes to Primavera or MS Project schedule are propagated to linked DP model.
Bentley	ProjectWise Navigator V8i	This is a standalone application that provides a series of services for: Importing multiple 2D and 3D design files from many sources (DWG, DGN, DWF, etc.) and from Bentley’s iModel design system Reviewing 2D drawings and 3D models concurrently Following links between data files and components Reviewing interferences (clashes), and viewing and analyzing schedule simulations
Innovaya	Visual Simulation	Links any 3D design data in DWG with either MS Project or Primavera scheduling tasks and shows projects in 4D. Generates simulation of construction process. Synchronizes changes made to either the schedule or to 3D objects. Uses color codes to detect potential schedule problems such as objects assigned to two concurrent activities or not assigned to any activity.
Autodesk	Navisworks Simulate	The Simulate module includes all the features of Naviswork’s visualization environment and supports the largest number of BIM formats and best overall visualization capabilities. The Simulate module supports automatic and manual linking to imported schedule data from a variety of schedule applications. Manual linking is tedious and not user-friendly and there are few custom 4D features.
Synchro Ltd.	Synchro Professional Pi	This is a powerful new (since 2007) 4D tool with the most sophisticated scheduling capabilities of any of the 4D software. The tool requires deeper knowledge of scheduling and project management than the other tools to take advantage of its risk and resource analysis features. The tool includes built-in tools to visualize risk, buffering, and resource utilization in addition to basic 4D visualization. It accepts building model objects and schedule activities from a variety of sources. These objects are then linked using a visual interface and managed on either a single computer or their server for multi user access. It also supports a 2-way update capability that keeps updates in either Synchro or a linked schedule in synch.
Vico Software	Virtual Construction	Virtual Construction 5D construction planning system consisting of Constructor, Estimating, Control and 5D Presenter. The building model is developed in Constructor or imported from another BIM-authoring system and objects are assigned recipes that define the tasks and resources needed to build or fabricate them. Quantities and costs are calculated in Estimator, schedule activities are defined and planned using line-of-balance (LOB or location-based) techniques in Control and then the 4D construction simulation is visualized in Presenter. As an alternative to using Control, schedule dates can be imported from Primavera or MS Project. Changes in the scheduling system are automatically reflected in the 4D visualization.





**FIGURE 6-13** Diagram showing two different 4D modeling processes.

The manual process is typically done within an available CAD, BIM, or visualization software. Specialized 4D software eliminates some steps, and provides direct links to the schedule and building model thus making the process faster and more reliable.



**FIGURE 6-14** Diagram showing the key data interfaces of a 4D model.

(A) Four-dimensional hierarchy or grouping of components related to activities in the schedule. (B) Organization of CAD data provided by design and engineering organizations. (C) Schedule data that can be illustrated hierarchically but is typically a set of activities with properties, such as start and finish dates. (D) Activity types that define the visual behavior of the 4D model.

tools only import geometry, geometry names, and hierarchy. This may be sufficient for basic 4D modeling, but other data may be needed so users can view object properties or filter or query based on this data.

- **Schedule import capabilities:** What schedule formats does the tool import and are the formats native files, text files? Some scheduling applications like Primavera work with a database. If so, the tool will need to support connections to the database and extraction of the schedule data.
- **Merge/update for 3D/BIM building model:** Can users merge multiple files into a single model and update portions or all of the model? If a project involves models created in multiple BIM tools, the 4D modeling process will support import and merging these models into one tool. Thus, the 4D tool must provide this capability.
- **Reorganization:** Can you reorganize the data after it has been imported? (See discussion in following section.) Tools that support easy reorganization of model components will greatly expedite the modeling process.
- **Temporary components:** Can users add (and later remove) temporary components such as scaffolds, excavation areas, storage areas, cranes, and so forth to the 4D model? In many cases, users have to create these components and import them with the model geometry. Ideally, the 4D tool would have a library to allow users to quickly add these components.
- **Animation:** Can you simulate detailed crane operations, or other installation sequences? Some 4D tools allow users to “move” objects over a specified time period to allow visualization of equipment movement.
- **Analysis:** Does the tool support specific analyses such as time-space conflict analysis, to identify activities happening in the same space.
- **Output:** Can users easily output multiple snapshots for specified periods of time or create movies with predefined views and time periods? The custom output features will facilitate sharing the model with the project team.
- **Automatic linking:** Can users automatically link building components to schedule items based on fields or rules? This is useful for projects with standard naming conventions.

#### 6.7.4 BIM-Supported Planning and Scheduling Issues and Guidelines

While the mechanics of the planning and scheduling process may vary depending on the planner’s tools, there are several issues that any planner or 4D modeling team should consider when preparing and developing a 4D model.

### ***Model Scope***

If the model has been developed for marketing or a design competition, its life will be relatively short. The appropriate level of detail depends on what the client has requested. If the team intends to use the model for the duration of the project, then a plan should outline when to migrate from a 90-day or higher-level schedule containing perhaps 100 to 300 activities to a detailed, one-week to three-week look-ahead schedule containing more detailed activities. Teams may start with constructing “shells” of buildings and then replace these buildings with detailed interiors.

### ***Level of Detail***

The level of detail is affected by the size of the model, the time allotted for building it, and what critical items need to be communicated. An architect may build a highly detailed wall system to support a rendering for comparing materials. The contractor may also elect to represent this system using a single component, because the critical issues are sequencing of the floors or wall sections, not the wall system’s sequence of installation. In other cases, the sequencing of detailed components, such as a sophisticated structural earthquake system, may require a more detailed model for each installation step. The construction tasks required to build a given object may also require multiple activities, for example, a foundation footing object requires excavation, forming, placing rebar, placing concrete, curing concrete, and stripping forms.

Planners can use a single component to represent multiple activities. A single wall section can be used to show formwork, rebar placement, concrete pour, concrete finishing, and wall finishes. The team can apply multiple activities and activity types to a single component.

### ***Reorganization***

4D tools often allow the scheduler to reorganize or create custom groupings of components or geometric entities. This is an important feature because the way that the designer or engineer organizes a model is not usually sufficient for relating components to activities. For example, the designer may group systems of components for ease of duplicating when creating the model, such as a column and a footing. The planner, however, will organize these components into zones of slabs or footings. Figure 6–14 shows a design hierarchy and a 4D hierarchy for two different organizations of a model. This ability to reorganize is critical for developing and supporting a flexible and accurate 4D model.

**FIGURE 6-15**

A 4D model snapshot showing scaffolding.

Adding temporary equipment is often critical for determining the feasibility of the schedule; the details allow subcontractors and planners to visually assess safety and constructability issues. (See color insert for full color figure.)

Image provided courtesy of M.A. Mortenson, Inc.



### Temporary Components

The building model should reflect the construction process so that even temporary structures, excavation details, and other features that exist during construction can be shown in the 4D simulation. Figure 6-15 shows a 4D model that contains scaffolding to help construction planners evaluate safety and constructability issues. The scaffolding is necessary because it will influence spatial constraints for people and equipment.

### Decomposition and Aggregation

Objects shown as a single entity, such as a slab, may need to be broken into portions to show how they will be constructed. Another issue that planners face is how to break up specific components, such as walls or roofs, that a designer or engineer would model as a single component but the planner would divide or break up into zones. Most specialized tools do not provide this capability, and the planner must perform these “break-ups” within the 3D/BIM tool.

### Schedule Properties

Early start and completion dates are often used for 4D simulation. It may be desirable, however, to explore other dates, such as a late start or finish or a leveled start or finish, to view the impact of alternative schedules on the visual simulation of the construction process. Additionally, other schedule properties are valuable in the 4D modeling process that are often project-specific.

For example, in one study a team associated specific activities with the number of hospital beds that were either taken out of service or made operational so that the team could visualize, at any time, the number of hospital beds available and ensure that a minimum number could remain in use. It is also possible to code each activity with a property titled “Area,” or “Responsibility” so that the model can show who is responsible for certain activities and quickly identify trades working near each other to improve coordination.

---

## 6.8 INTEGRATION WITH COST AND SCHEDULE CONTROL AND OTHER MANAGEMENT FUNCTIONS

During the construction process, organizations use a variety of tools and processes to manage and report on the project’s status. These range from schedule and cost control systems to systems for accounting, procurement, payroll, safety, and the like. Many of these systems report or rely on design and building-component information, yet they are not typically linked or associated with design drawings or BIM. This leads to redundant efforts of manually entering design information and identifying problems associated with the synchronization of various systems and processes. BIM software can provide vital support for these tasks, because it has detailed quantity and other component information that can be linked to other applications. Furthermore, contractors and project stakeholders can gain new insights by leveraging a graphic model to visually analyze project progress and highlight potential or existing problems. Some examples of how organizations are using 3D/BIM to support these tasks are:

- **Track variances between budget and actual cost:** Using the Vico Cost Explorer (Vico 2010) a user can import actual costs into the Vico model, and then visually see where there are significant variances between cost and budget using the 3D model. This allows better understanding of how a project is tracking against its budget and where the key problems are located.
- **Project status:** Each component can have a field named “status,” and depending on the project, values may be “in design,” “approved for construction review,” “in fabrication,” and so forth. These fields can then be associated with colors so that the team can quickly determine the status of the facility and identify bottlenecks or areas that are behind schedule.

- **Procurement purchasing:** Since BIM objects define what needs to be purchased, it is possible to make purchases directly using the BIM tool. At the time the second edition of this book was updated (mid-2010), this capability was in an early stage of development. This capability will certainly improve, as product manufacturers develop models of their products that can be stored on Internet servers and found using search systems. A good example of a BIM procurement application has been developed by 1st Pricing (1stPricing 2010). Using downloadable free plug-ins, it allows procurement within AutoCAD, ArchiCAD, Architectural Desktop, TurboCAD, and Revit. This product provides real-time quotes on doors and windows delivered to the jobsite based on zip code. Other types of components are being added to the system. Recently, a LEED evaluation feature was added to this system that shows the LEED rating for a given material. Autodesk Seek (Autodesk Seek 2010) is another system that allows AutoCAD and Revit users to find a wide variety of products from U.S. manufactures and include these objects and their associated specifications into the design model. These are automatically included in quantity takeoffs, material schedules, and are properly visualized in 2D and 3D views.
- **Procurement tracking:** Another important issue is the procurement status of services and material. Often, schedules consist of large numbers of construction activities, which makes it difficult to relate parallel design and procurement activities. By tracking the status of these activities, planners can perform queries to easily identify gaps in the procurement process as they relate to design and construction. By linking the schedule to a building information model, it is also possible to visualize where procurement delays are likely to impact the building. For example, if a long lead item is scheduled to be installed in two months and the procurement process is not yet complete, the team can address the issue quickly to prevent further downstream delays. A visual link to a building model helps to better predict the impact that procurement delays will have on construction.
- **Safety management:** Safety is a critical issue for all construction organizations. Any tool that supports safety training, education, and reveals unsafe conditions is valuable to the construction team. A visual model allows teams to assess conditions and identify unsafe areas that might otherwise go unrealized until the team is in the field. For example, on a theme park project, a team modeled envelopes for testing rides to ensure that no activities were taking place during the testing period within the test envelope. Using 4D simulation, they identified a conflict and

resolved it ahead of time. For construction of a large steel frame that envelopes two buildings of the Yas Island project in Abu Dhabi, cylinders were used to model the spaces occupied by the activities of welding crews; clash detection between cylinders was then used to identify possible exposures of workers to dangers posed by other teams from time to time.

---

## 6.9 USE FOR OFFSITE FABRICATION

Offsite fabrication requires considerable planning and accurate design information. It is becoming more common for contractors to fabricate components offsite to reduce labor costs and risks associated with onsite installation. Today, many types of building components are produced and/or assembled offsite in factories and delivered to the site for installation. BIM provides the capability for contractors to input BIM component details directly, including 3D geometry, material specifications, finishing requirements, delivery sequence, and timing before and during the fabrication process. In this section, the benefits from the perspective of the contractor are discussed. The benefits from the perspective of the fabricator are explained in detail in Chapter 7.

Coordination of subcontractors' activities and designs constitutes a large part of a contractor's added value to a project. Contractors able to exchange accurate BIM information with fabricators can save time by verifying and validating the model. This reduces errors and allows fabricators to participate earlier in the preplanning and construction process.

There are excellent examples of close coordination and exchange of models between contractors and fabricators in the steel and sheet metal industries. As discussed in Chapter 7, many steel fabricators leverage 3D technologies to manage and automate the steel fabrication process. The adoption of product model exchange formats, such as the CIS/2 format (explained in detail in Chapter 3) (CIS/2 2007), greatly facilitates the exchange of information between design and engineering, contractors, and fabricators. These conditions allow project teams to coordinate and optimize the sequence of steel or sheet metal. In Chapter 9, the benefits of a close digital relationship between a contractor and a fabricator are captured in the Crusell Bridge case study and in several other case studies.

The structural steel industry is well-positioned to leverage BIM due to the efforts of the AISC (AISC 2007) and the development of the CIS/2 (CIS/2 2007; <http://cic.nist.gov/vrml/cis2.html>) format. Other standards are being developed for precast concrete but are not yet in production use. The National

BIM Standards (NBIMS) effort (NIBS 2007) considers how to use building information models to provide information for fabrication. The NBIMS is reviewed in Chapter 3. Further details, including BIM technology requirements and available software products, are discussed in Chapter 7.

---

## 6.10 USE OF BIM ONSITE: VERIFICATION, GUIDANCE, AND TRACKING OF CONSTRUCTION ACTIVITIES

Contractors must field-verify the installation of building components to ensure that dimensional and performance specifications are met. When errors are found, the contractor must spend further time rectifying them. The building model can be used to verify that actual construction circumstances match those shown in the model. Note that even when a project team creates an accurate model, human error during installation remains a possibility, and catching these errors as they occur or as soon as possible has great value. An example of this occurred on the Letterman Digital Arts Center (LDAC) in San Francisco, where the project team built a complete model after the project had been designed and subsequently documented a field error in a report (Boryslawski 2006) as described in the following excerpt:

“During one of the daily rounds of onsite photography, we recognized a critical error shown in the positioning of concrete formwork, which was quickly confirmed by referencing the BIM. This error occurred when the formwork layout person measured from a column that was off the standard grid to the edge of the concrete slab. Pouring more concrete in this complex post-tension slab construction would have had serious consequences not only for the contractor but also for the entire project, as there were three more floors to be built above this floor. The problem was solved just as the concrete was being poured, saving what would have most definitely been a major expense.”

In this situation, the intimate knowledge gained by virtually building the project allowed the team to discover these field errors. The team combined traditional field-verification processes of daily site walks with model reviews to detect potential field errors.

Automated techniques are evolving to support field verification, guide layout, and track installation. Some examples of these are:

- **Laser scanning technologies:** Contractors can use laser technologies, such as laser measurement devices that report data directly to a BIM tool,



to verify that concrete pours are situated in exactly the correct location or that columns are properly located. Laser scanning can also be used effectively for rehabilitation work and capturing as-built construction details. Laser scanning services are now widely available; buildings are scanned and operators then interactively generate the building model objects that represent the scanned components. The end result can then be imported into a BIM system. A good example of laser scanning use is presented in the Portland Marriott Hotel case study in Chapter 9.

- **Machine-guidance technologies:** Earthwork contractors can use machine-guided equipment to guide and verify grading and excavation activities driven by dimensions extracted from a 3D/BIM model. These rely on various technologies, including laser and GPS.
- **GPS technologies:** Rapid advances in global positioning systems (GPS) and the availability of mobile GPS devices offer contractors the ability to link the building model to GPS to verify locations. Systems developed at Carnegie-Mellon University and used by transportation departments to facilitate delivery of information to field workers on road or bridge construction are managed through the coordination of GPS and 2D/3D/BIM, enabling field crews to quickly find related information based on their location.
- **RFID tags:** Radio Frequency Identification (RFID) tags can support the tracking of component delivery and installation onsite. BIM components that include references to RFID tags can automatically update work status with links to field scanning devices and provide contractors with rapid feedback on field progress and installation. An example of large-scale use of this capability, in construction of the Maryland General Hospital, is discussed in Chapter 9. It is also described at the Vela Systems Web site: [www.velasystems.com/products/field-BIM/](http://www.velasystems.com/products/field-BIM/).

The use of BIM in the field will increase dramatically as hand-held wireless devices and methods to deliver BIM information to field workers becomes commonplace. The availability of software tools for these devices is growing rapidly (Vela 2010).

---

## 6.11 SYNERGIES OF BIM AND LEAN CONSTRUCTION

When using lean construction, value to the customer is maximized through continuous process improvements that optimize flow and reduce waste. These basic principles are drawn from lean production, and much has been learned

from the Toyota Production System (TPS). Naturally, significant adaptation is needed before the ideas and tools can be applied to construction. Adaptation has been practical and theoretical, and the process has given rise to new ways of thinking about production in construction, such as the Transformation-Flow-Value (TFV) concept defined by Koskela (1992, 2000).

Some lean construction tools and techniques, such as the Last Planner System™ (Ballard 2000), require commitment and education, but can generally be implemented with little or no software support. Nevertheless, there is a strong synergy between lean construction and BIM, in that the use of BIM fulfills some lean construction principles and greatly facilitates fulfillment of other lean principles. There are many causes of waste in construction that result from the way information is generated, managed, and communicated using drawings. Many of these, such as inconsistencies between design documents, restricted flow of design information in large batches, and long cycle times for requests for information, have been discussed earlier in this book. BIM goes a long way to removing these wastes, but it also does something more—it improves workflow for many actors in the construction process, even if they make no direct use of BIM.

In a study of this relationship, Sacks et al. (2010) listed 24 lean principles (see Table 6–2) and 18 BIM functionalities and identified 56 explicit interactions between them, of which 52 were positive interactions. The first area of significant synergy is that the **use of BIM reduces variation**. The ability to visualize form and to evaluate function, rapid generation of design alternatives, the maintenance of information and design model integrity (including reliance on a single information source and clash checking), and automated generation of reports, all result in more consistent and reliable information that greatly reduces the waste of rework and of waiting for information. This affects all members of a building's design team, but its economic impact on those involved directly in construction is much greater.

The second area of synergy is that **BIM reduces cycle times**. In all production systems, an important goal is to reduce the overall time required for a product from entry into the system to completion. This will help reduce the amount of work in process, accumulated inventory, and the ability of the system to absorb and respond to changes with minimal waste. The Sutter Medical Center case study (Chapter 9) reports how BIM enabled the project team to reduce cost-estimation cycles from months to just two or three weeks, which was a critical enabler of the target costing approach that was used. BIM use for automated generation of construction tasks, construction process simulation, and 4D visualization of construction schedules all serve to reduce cycle times for construction operations because they help reveal process conflicts.

**Table 6-2** Lean Principles (Sacks et al. 2010)

<b>Principal Area</b>	<b>Principle</b>
<b><u>Flow process</u></b>	<p><b>Reduce variability</b> Get quality right the first time (reduce product variability) Improve upstream flow variability (reduce production variability)</p> <p><b>Reduce cycle times</b> Reduce production cycle durations Reduce inventory</p> <p><b>Reduce batch sizes (strive for single-piece flow)</b></p> <p><b>Increase flexibility</b> Reduce changeover times Use multiskilled teams</p> <p><b>Select an appropriate production control approach</b> Use pull systems Level the production</p> <p><b>Standardize</b></p> <p><b>Institute continuous improvement</b></p> <p><b>Use visual management</b> Visualize production methods Visualize production process</p> <p><b>Design the production system for flow and value</b> Simplify Use parallel processing Use only reliable technology Ensure the capability of the production system</p>
<b><u>Value generation process</u></b>	<p><b>Ensure comprehensive requirements capture</b></p> <p><b>Focus on concept selection</b></p> <p><b>Ensure requirement flow down</b></p> <p><b>Verify and validate</b></p>
<b><u>Problem-solving</u></b>	<p><b>Go and see for yourself</b></p> <p><b>Decide by consensus, consider all options</b></p>
<b><u>Developing partners</u></b>	<b>Cultivate an extended network of partners</b>

Thirdly, **BIM enables visualization of both construction products and processes.** The Crusell Bridge case study (Chapter 9) explains how a model, maintained by the contractor at the site and synchronized with the designers' and the steel fabricator's models, was used to provide detailed product

views for rebar installers and others that boosted productivity, as well as being used with 4D animations to support exploration of the process plans before and during Last Planner System™ meetings. Where BIM systems are integrated with supply chain partner databases, they provide a powerful mechanism for communicating signals to pull production and delivery of materials and product design information. This was exemplified in the Meadowlands Stadium project, where thousands of precast concrete risers were tracked through fabrication, delivery, and erection with status results displayed on a color-coded building model (this use is described in Section 7.3.7 in the next chapter).

Finally, and perhaps most obviously, where used effectively **BIM supports a number of lean principles in the design stages**. Clients understand design intent better when it is expressed in models, and designers can perform better performance analyses. Requirements capture and information flows are improved. The much-reduced cycle times for drawing production means that the conceptual design stage can be extended: the “last responsible moment” for decisions can be postponed longer, allowing more alternatives to be evaluated more thoroughly.

Increased prefabrication of building parts and assemblies, as described in the 100 11th Avenue NYC case study (Chapter 9), reveals how BIM’s support for prefabrication leads to leaner practice in all of the areas listed above. Prefabrication reduces variation in product quality and process timing, reduces cycle times for production and installation, and supports the use of various tracking technologies that help make the process visible. For more detailed discussion of these aspects, see Chapter 7.

Considering these synergies, it becomes clear why the American Institute of Architects document on Integrated Project Delivery, which is an essentially lean approach (Eckblad et al. 2007), states: “Although it is possible to achieve Integrated Project Delivery without Building Information Modeling, it is the opinion and recommendation of this study that it is essential to efficiently achieve the collaboration required for Integrated Project Delivery.”

---

## 6.12 IMPLICATIONS FOR CONTRACT AND ORGANIZATIONAL CHANGES

The above descriptions of BIM-supported work processes for contractors emphasize the advantages of early and continual collaboration of the project team so that key project participants are involved in the development of the virtual model. Contractors of all types that integrate their practice around BIM, as opposed to traditional 2D CAD, will reap the greatest advantages.

Projects that involve designers as well as general and major subcontractors, by incorporating constructability, cost, and construction planning knowledge earlier in the process, will experience project-wide benefits for all team members. The advantages that an integrated, collaborative, BIM-supported approach can bring will make it a favored and widely used method in the future.

This organizational approach will, of course, require new contracts that encourage close collaboration and sharing of information, as well as a sharing of the technology's associated benefits. A new approach to sharing risks and setting fees may also be required, because the increased emphasis on early collaboration means that efforts by team members and the benefits they produce may change. Advanced owners are already experimenting with Integrated Project Delivery for exploring how to better incorporate contractor (general and key trades) involvement through a BIM-driven process. Some of these are discussed in the case studies presented in Chapter 9.

The Associated General Contractors (AGC) is closely following the implications of BIM for their members. They have published a document titled, *The Contractors' Guide to Building Information Modeling-BIM* which is now in its second edition. There is also BIM instructional material and suggested contract language for a BIM-related contract. These are all available at their Web site bookstore. The report is based on first-hand experience provided by contractors that have already used BIM. The guide discusses the implementation of BIM using 2D drawings produced by the design team and contrasts this with the faster and more accurate process of starting with a 3D building model generated by the design team. The guide suggests that an experienced digital modeler can create a building model from 2D drawings in one to two weeks at a cost of 0.1 to 0.5 percent of the total construction costs. Contractors must balance these costs with the many potential benefits of BIM, as discussed earlier in this chapter.

With respect to changes in management responsibilities, *The Contractor's Guide to BIM* (AGC 2006) says:

"Whether the design is issued in the form of 2D printed documents or a 3D electronic media or in a combination of both, the responsibilities of the members of the project team remain unchanged. The important issue is to ensure that project team members thoroughly understand the nature and exactitude of the information that is being conveyed."

It adds:

"Contractors and Construction Managers need to recognize that coordination whether with BIM technology or a light table is a core service not

an added service. BIM tools that can facilitate a great deal of coordination are now available and when applied appropriately they can reduce the cost and time of construction. The question is not whether BIM will be used on a project, but to what extent it will be used. It is known that BIM coordination improves communication, which decreases construction cost and time, thus reducing risk. Contractors and Construction Managers have a responsibility to evaluate the costs of various implementation processes and provide the results of this evaluation to Owners and design teams in quantifiable terms.

As the leaders of construction coordination, Contractors and Construction Managers have a responsibility to encourage and facilitate the sharing and distribution of BIM technology on a project. They must also understand and convey the nature of the information that is being shared. Appropriate contract language that will foster the open sharing of BIM information must be developed. The contract language cannot alter the relationships of the project team members or change their responsibilities beyond their ability to perform. As an example, if a designer approves an electronic file prepared by a detailer, and this file contains a dimensional inaccuracy, the designer must be protected to the same extent that they would had the approval document been a printed drawing.”

Finally, while the guide does not recommend specific contract changes for accommodating BIM, it suggests that all parties agree to rely on the model (as opposed to 2D drawings in cases where the two representations do not agree); it suggests that all members of the team be given access to and take responsibility for their part of the model; and it recommends that an audit trail be maintained that tracks all changes made to the model. Clearly, this is an area that is rapidly evolving with the use of BIM tools.

---

### **6.13 BIM IMPLEMENTATION**

Contractors working in close collaboration with project teams during the design phase will encounter fewer barriers to BIM adoption compared to contractors working in a design-bid-build environment. In the latter case, the collaboration process does not start until the job has been awarded to the low bid contractor; in the former, the contractor is involved with design decisions and can contribute construction knowledge to the design. The same applies to the trade contractors that participate in the project. This is an important advantage of an IPD contract.

On integrated projects, the contractor needs to understand how the use of 3D/BIM, rather than 2D drawings, can be used to support coordination, estimating, scheduling, and project management. A good implementation plan involves making sure that management and other key staff members acquire a thorough understanding of how BIM is used to support specific work processes. This should be done at a companywide level, although any particular project could be used as a starting point. If the architects and other designers on the company's projects are not all using BIM technology, it will be necessary for the contractor to build models that are appropriate for the above functions. This will expose them to a deeper understanding of model building and the required standards—for colors, objects, construction knowledge, and so forth—that need to be incorporated into the model. Training can be obtained from BIM software firms or from specialized consultants. The cost of developing the model will be more than offset by the eventual savings in errors, shortened project duration, better use of prefabrication options, fewer workers in the field, and improved collaboration among the team. This topic is discussed in greater detail for subcontractors and fabricators in Chapter 7.

## Chapter 6 Discussion Questions

---

1. There is tremendous variation in the size and type of construction companies. In 2004, what percent of firms were composed of one to nine people? In what sector were a majority of these firms?
2. What are the main advantages of design-build over design-bid-build contracts? Why does the use of BIM favor the design-build contract? For public projects, why are design-bid-build contracts often preferred (see also Chapter 1, Section 1.1.2)?
3. What are the key innovations in procurement in IPD contracts? How do they change the commercial interests of construction contractors in construction projects? What uses of BIM are enabled by an IPD contract, as opposed to design-bid-build or even design-build contracts?
4. From the contractor's point of view, what kinds of information should a building model contain? If the architect uses BIM

- to design a building, what information needed by the contractor is **not** likely to be present?
5. What approaches are available to develop a building model that can be used by the contractor? What are the limitations and benefits of each approach?
  6. What level of detail is needed in a building model for useful clash detection? What are the reasons for detecting soft as opposed to hard clashes? What role do subcontractors play in the clash detection process?
  7. What are the main advantages and limitations of using BIM for preparing a cost estimate? How can an estimator link the building model to an estimating system? What changes are likely to the model to provide support for accurate quantity takeoff?
  8. What are the basic requirements for performing a 4D analysis of a construction schedule? What are the contractor's options for obtaining the information needed to carry out this analysis? What major benefits can be obtained from this analysis?
  9. How can BIM be linked to cost and schedule control systems? What advantages does this provide?
  10. What are the main advantages of using BIM for procurement? Why is it still difficult to do this?
  11. What are the requirements for using a building model for offsite fabrication? What types of exchange standards are needed for fabrication of steel members?
  12. Consider the Crusell Bridge case study (Chapter 9). In what specific ways did use of BIM make the project processes leaner? In what ways did the contractor fail to exploit the model to apply lean construction?
  13. What types of organizational and contractual changes are needed for effective BIM use?



# BIM for Subcontractors and Fabricators

---

## 7.0 EXECUTIVE SUMMARY

Buildings have become increasingly complex. They are one-of-a-kind products requiring multidisciplinary design and fabrication skills. Specialization of the construction trades and economies of prefabrication contribute to increasingly larger proportions of buildings' components and systems being preassembled or fabricated offsite. Unlike the mass production of off-the-shelf parts, however, complex buildings require customized design and fabrication of "engineered to order" (ETO) components, including: structural steel, precast concrete structures and architectural façades, curtain walls of various types, mechanical, electrical and plumbing (MEP) systems, timber roof trusses, and reinforced concrete tilt-up panels.

By their nature, ETO components demand sophisticated engineering and careful collaboration between designers to ensure that pieces fit within the building properly without interfering with other building systems and interface correctly with other systems. Design and coordination with 2D CAD systems is error-prone, labor-intensive, and relies on long cycle times. BIM addresses

these problems in that it allows for the “virtual construction” of components and coordination among all building systems prior to producing each piece. The benefits of BIM for subcontractors and fabricators include: enhanced marketing and rendering through visual images and automated estimating; reduced cycle times for detailed design and production; elimination of almost all design coordination errors; lower engineering and detailing costs; data to drive automated manufacturing technologies; and improved preassembly and prefabrication.

Accurate, reliable, and ubiquitous information is critical to the flow of products in any supply chain. For this reason, BIM systems can enable leaner construction methods if harnessed across an organization’s many departments or through the entire supply chain. The extent and depth of these process changes goes hand in hand with the extent to which the building information models developed by participating organizations are integrated.

To be useful for fabrication detailing, BIM platforms need to support at least parametric and customizable parts and relationships, provide interfaces to management information systems, and be able to import building model information from building designers’ BIM platforms. Ideally, they should also offer good information for model visualizations and export data in forms suitable for automation of fabrication tasks using computer-controlled machinery.

Within the chapter, the major classes of fabricators and their specific needs are discussed. For each fabricator type, appropriate BIM software platforms and tools are listed and the leading ones are surveyed. Finally, the chapter provides guidance for companies planning adoption of BIM. To successfully introduce BIM into a fabrication plant with its own in-house engineering staff, or into an engineering detailing service provider, adoption must begin with setting clear, achievable goals with measurable milestones. Human resource considerations are the leading concern; not only because the costs of training and setup of software to suit local practices far exceed the costs of hardware and software, but also because the success of any BIM adoption will depend on the skill and goodwill of the people tasked with using the technology.

---

## 7.1 INTRODUCTION

The professional gap between designers and builders that became pronounced during the European Renaissance has continued to widen over the centuries, while building systems have grown increasingly complex and technologically advanced. Over time, builders became more and more specialized and began to produce building parts offsite, first in craft shops and later in industrial facilities, for subsequent assembly onsite. As a result, designers had less and less

control over the entire design; expert knowledge for any given system lay within the realm of specialized fabricators. Technical drawings and specifications on paper became the essential medium for communication. Designers communicate their intent to builders, and builders detail their proposed solutions. The builder's drawings, commonly called "shop drawings," serve two purposes: to develop and detail the designs for production and, no less importantly, to communicate their construction intent back to the designers for coordination and approval.

In fact, the two-way cycle of communication is not simply a review but an integral part of designing a building. Even more so, this has become the case where multiple systems are fabricated and their design must be integrated consistently. Drawings are used to coordinate the location and function of various building system parts. This is the case today for all but the simplest buildings.

In traditional practice, paper drawings and specifications prepared by fabricators for designers fulfill additional vital purposes. They are a key part of commercial contracts for the procurement of fabricators' products. They are used directly for installation and construction, and they are also the primary means for storing information generated through the design and construction process.

For subcontractors and fabricators, BIM supports the whole collaborative process of design development, detailing, and integration. In many recorded cases, BIM has been leveraged to enable greater degrees of prefabrication than was possible without it, by shortening lead times and deepening design integration. As noted in Chapter 2, object-based parametric design platforms had already been developed and used to support many construction activities, such as structural steel fabrication, before the earliest comprehensive BIM platforms became available.

Beyond these short-term impacts on productivity and quality, BIM enables fundamental process changes, because it provides the power to manage the intense amount of information required of "mass customization," which is a key precept of lean production (Womack and Jones 2003).

As the use of lean construction methods (Howell 1999) becomes widespread, subcontractors and fabricators will increasingly find that market forces will compel them to provide customized prefabricated building components at price levels previously appropriate for mass-produced repetitive components. In manufacturing, this is called "mass customization."

After defining the context for our discussion (Section 7.2), this chapter describes the potential benefits of BIM for improving various facets of the fabrication process, from the perspective of the subcontractor or fabricator responsible for making and installing building parts (Section 7.3) to the fundamental process changes to be expected (Section 7.4). BIM system requirements for effective use by fabricators are listed and explained for modeling

and detailing in general (Section 7.5). Detailed information is provided for a number of specific trades (Section 7.6). Significant software packages for fabricators are listed, and pertinent issues concerning the adoption and use of BIM are discussed (Section 7.7).

---

## 7.2 TYPES OF SUBCONTRACTORS AND FABRICATORS

Subcontractors and fabricators perform a very wide range of specialized tasks in construction. Most are identified by the type of work they do, or the type of components they fabricate. For a discussion of the ways in which they can exploit BIM, the degree of engineering design required in their work is a useful way of classifying them. Looking beyond bulk raw materials, building components can be classified as belonging to one of three types:

1. **Made-to-stock components**, such as standard plumbing fixtures, dry-wall panels and studs, pipe sections, and the like.
2. **Made-to-order components**, such as pre-stressed hollow-core planks,<sup>1</sup> and windows and doors selected from catalogs.
3. **Engineered-to-order components**, such as the members of structural steel frames, structural precast concrete pieces, façade panels of various types, custom kitchens and other cabinet-ware, and any other component customized to fit a specific location and fulfill certain building functions.

The first two classifications are designed for general use and not customized for specific applications.<sup>2</sup> These components are specified from catalogs. Most BIM systems enable suppliers to provide electronic catalogs of their products, allowing designers to embed representative objects and direct links to them in building information models. The suppliers of these components are rarely involved in their installation or assembly onsite. As a result, they are rarely involved directly in the design and construction process. For this reason, this chapter focuses on the needs of designers, coordinators, fabricators, and installers of building components of the third type: engineered-to-order (ETO) components.

---

<sup>1</sup> Hollow-core planks are pre-engineered but can be custom-cut to arbitrary lengths.

<sup>2</sup> They are distinguished in that the second type is only produced as needed, usually for commercial or technological reasons, such as high inventory costs or short shelf-life.

### 7.2.1 Engineered-to-Order Component Producers

ETO producers typically operate production facilities that manufacture components that need to be designed and engineered prior to actual production. In most cases, they are subcontracted to a building's general contractor or, in the case of a project being executed by a construction management service company, they are subcontracted to the owner. The subcontract typically encompasses detailed design, engineering, fabrication, and erection of their products.

Although some companies maintain large in-house engineering departments, their core business is fabrication. Others outsource part or all of their engineering work to independent consultants (dedicated design service providers; see below). They may also subcontract erection or installation of their product onsite to independent companies.

Some examples of ETO producers are provided in Table 7-1 along with statistics of their respective market volume as reflected in the United States economic census in 2002 and in 2007. In addition, there are building construction trades that do not function exclusively as ETO producers but offer significant ETO component content as part of their systems. Examples are: plumbing, heating, ventilation and air-conditioning (HVAC), elevators and escalators, and finish carpentry.

### 7.2.2 Design Service Providers

Design service providers offer engineering services to producers of engineered-to-order components. They perform work on a fee basis and generally do not participate in actual fabrication and onsite installation of the components they design. Service firms include: structural steel detailers, precast

**Table 7-1** Engineered-to-Order Building Components and Their Annual Market Volume in the United States

<b>Engineered-to-order component fabricator/designer/coordinator</b>	<b>Value of specialized construction services in 2002 (\$1M)</b>	<b>Value of specialized construction services in 2007 (\$1M)</b>
Structural steel erection	\$5,047	\$7,788
Precast concrete	\$1,892	\$1,173
Curtain walls	\$1,707*	Unavailable
Timber trusses (floor and roof trusses)	\$4,487	\$5,383
Reinforcing bars for concrete	\$1,782	\$3,415

\*Estimate based on new construction for office and commercial buildings.

Sources: 2002 and 2007 Economic Census, U.S. Census Bureau, U.S. Department of Commerce. (U.S. 2004, 2010).

concrete design and detailing engineers, and specialized façade and curtain wall consultants, among others.

Designers of tilt-up concrete construction panels are a good example of such providers. Their expertise in engineering, designing, and preparing shop drawings enables general contractors or specialized production crews to make large reinforced concrete wall panels in horizontal beds onsite and then lift (or tilt) them into place. This onsite fabrication method can be implemented by relatively small contracting companies, by virtue of the availability of these design service providers.

### 7.2.3 Specialist Coordinators

Specialist coordinators provide a comprehensive ETO product provision service by bringing together designers, material suppliers, and fabricators under a “virtual” subcontracting company. The rationale behind their work is that they offer flexibility in the kinds of technical solutions they provide, because they do not have their own fixed production lines. This type of service is common in the provision of curtain walls and other architectural façades.

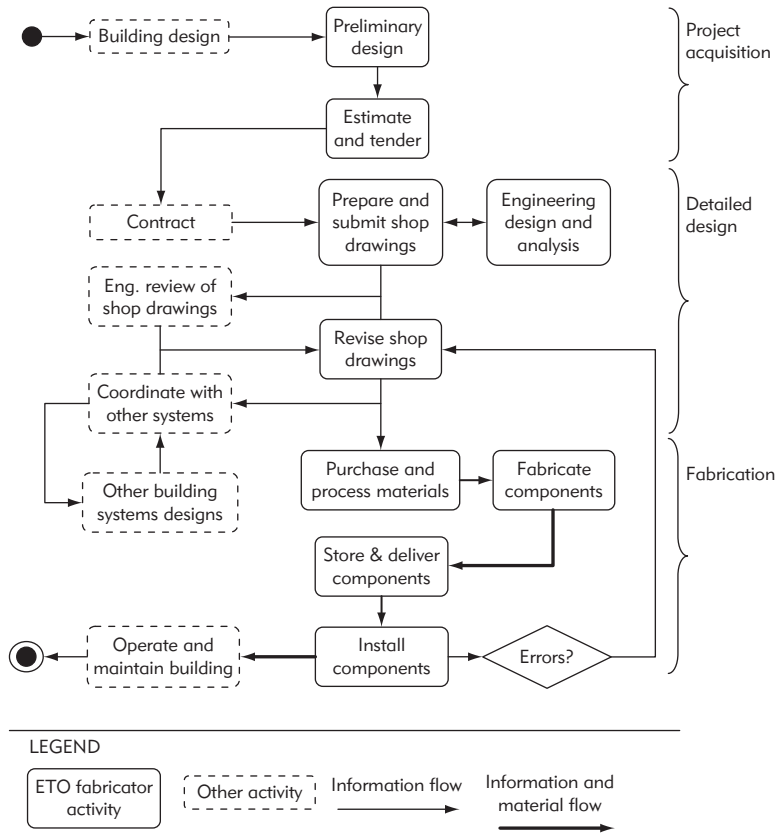
The 100 11th Avenue, New York, case study (see Chapter 9) is a good example of this kind of arrangement. The designers of the façade system assembled an ad hoc virtual subcontractor composed of a material supplier, a fabricator, an installer, and a construction management firm.

---

## 7.3 THE BENEFITS OF A BIM PROCESS FOR SUBCONTRACTOR FABRICATORS

Figure 7–1 shows the typical information and product flow for ETO components in building construction. The process has three major parts: project acquisition (preliminary design and tendering), detailed design (engineering and coordination), and fabrication (including delivery and installation). The process includes cycles that allow the design proposal to be formulated and revised, repeatedly if necessary. This typically occurs at the detailed design stage, where the fabricator is required to obtain feedback and approval from the building’s designers, subject not only to their own requirements but also to the coordination of the fabricator’s design with other building systems also in development.

There are a number of problems with the existing process. It is labor intensive, with much of the effort spent producing and updating documents. Sets of drawings and other documents have high rates of inaccuracies and inconsistencies, which are often not discovered until erection of the products onsite. The same information is entered into computer programs multiple times, each



**FIGURE 7-1**  
Typical information and product flow for a fabricator of ETO components.

time for a distinct and separate use. The workflow has so many intermediate points for review that rework is common and cycle times are long.

Leveraging BIM can improve the process in several ways. First, BIM can improve the efficiency of most existing steps in the 2D CAD process by increasing productivity and eliminating the need to manually maintain consistency across multiple drawing files. With deeper implementation, however, BIM changes the process itself by enabling degrees of prefabrication that remain prohibitive in coordination costs with existing information systems. When implemented in the context of lean construction techniques, such as with pull flow<sup>3</sup>

<sup>3</sup> Pull flow is a method for regulating the flow of work in a production system whereby production at any station is signaled to begin only when an “order” for a part is received from the next station downstream. This is in contrast to traditional methods where production is “pushed” by command from a central authority. In this context, pull flow implies that detailing and fabrication of components for any particular building section would begin only a short preset time before installation became possible for that section.

control of detailing, production, and installation, BIM can substantially reduce lead times and make the construction process more flexible and less wasteful.

In this section, the short-term benefits are first explained in an approximated chronological sequence with reference to the process map shown in Figure 7–1. Section 7.4 discusses the more fundamental process change.

### 7.3.1 Marketing and Tendering

Preliminary design and estimating are essential activities for obtaining work for most subcontractor fabricators. To win a project with a profitable price requires precision in measuring quantities, attention to detail, and the ability to develop a competitive technical solution—all of which demand significant time investments by the company’s most knowledgeable engineers. Generally, not all tenders are successful, and companies are required to estimate more projects than are eventually performed, making the cost of tendering a sizable part of the company’s overhead.

BIM technology aids engineers in all three of these areas: developing multiple alternatives, detailing solutions to a reasonable degree, and measuring quantities.

For marketing purposes, the persuasive power of a building model for a potential client is not limited to its ability to provide a 3D or photorealistic image of a proposed building design, as is the case for software that is limited to 3D geometric modeling. Its power lies in its ability to adapt and change designs parametrically and better exploit the embedded engineering knowledge, allowing for more rapid design development for satisfying clients’ needs to the greatest extent possible. The following excerpt describes the story of a precast concrete estimator’s experience using a BIM tool to develop and sell a design for a parking garage:

“To give you some background on this project, we started it as a design-build project for one of the salesmen. Bill modeled the entire garage (240’ wide × 585’ long × 5 supported levels), without connections or reinforcing, in 8 hours. It is composed of 1,250 pieces. We sent PDF images to the owner, architect, and engineer.

The next morning we had a conference call with the client and received a number of modifications. Bill modified the model by 1:30 PM. I printed out the plan, elevations, and generated a Web viewer model. I sent these to the client at 1:50 pm via email. We then had another conference call at 2:00 PM. Two days later, we had the project. The owner was ecstatic about seeing a model of his garage. Oddly enough, it’s



supposed to be 30 miles from our competitor's plant. In fact, their construction arm is who we will be contracted to.

We figured it would have taken 2 weeks in 2D to get to where we were in 3D. When we had the turnover meeting (a meeting we have to turnover scope from estimating to engineering, drafting and production) we projected the model on a screen to go over the scope of work. It went just as we envisioned. It was exciting to see it actually happen that way."

This example underscores how shortened response times—obtained through the use of BIM—enabled the company to better address the client's decision-making process.

The project referenced in this excerpt—the Penn National Parking Structure—is documented in further detail in the first edition of this book (Eastman et al. 2008). Alternative structural layout configurations were considered. For each, the producer automatically extracted a quantity takeoff that listed the precast pieces required. These quantities enabled the provision of cost estimates for each, allowing the owner and general contractor to reach an informed decision concerning which configuration to adopt.

### 7.3.2 Reduced Production Cycle Times

The use of BIM significantly reduces the time required to generate shop drawings and material takeoffs for procurement. This can be leveraged in three ways:

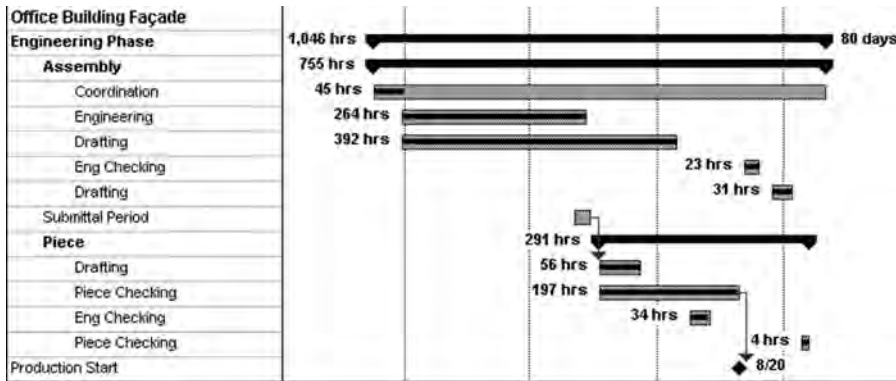
- To offer a superior level of service to building owners, for whom late changes are often essential, by accommodating changes later in the process than is possible in standard 2D CAD practice. Making changes to building designs that impact fabricated pieces close to the time of fabrication is very difficult in standard practice. Each change must propagate through all of the assembly and shop drawings that may be affected and must also coordinate with drawings that reflect adjacent or connected components to the piece that changed. Where the change affects multiple building systems provided by different fabricators or subcontractors, coordination becomes far more complex and time-consuming. With BIM platforms, the changes are entered into the model and updated erection and shop drawings are produced almost automatically. The benefit is enormous in terms of time and effort required to properly implement the change.
- To enable a "pull production system" where the preparation of shop drawings is driven by the production sequence. Short lead times reduce the system's "inventory" of design information, making it less vulnerable

to changes in the first place. Shop drawings are produced once a majority of changes have already been made. This minimizes the likelihood that additional changes will be needed. In this “lean” system, shop drawings are produced at the last responsible moment.

- To make prefabricated solutions viable in projects with restricted lead times between the contract date and the date demanded for the commencement of onsite construction, which would ordinarily prohibit their use. Often, general contractors find themselves committing to construction start dates with lead times that are shorter than the time required to convert conventional building systems to prefabricated ones, due to the long lead times needed for production design using 2D CAD. For example, a building designed with a cast-in-place concrete structure requires, on average, two to three months for conversion to precast concrete before the first required pieces can be produced. In contrast, BIM systems shorten the duration of design to a point where more components with longer lead times can be prefabricated earlier.

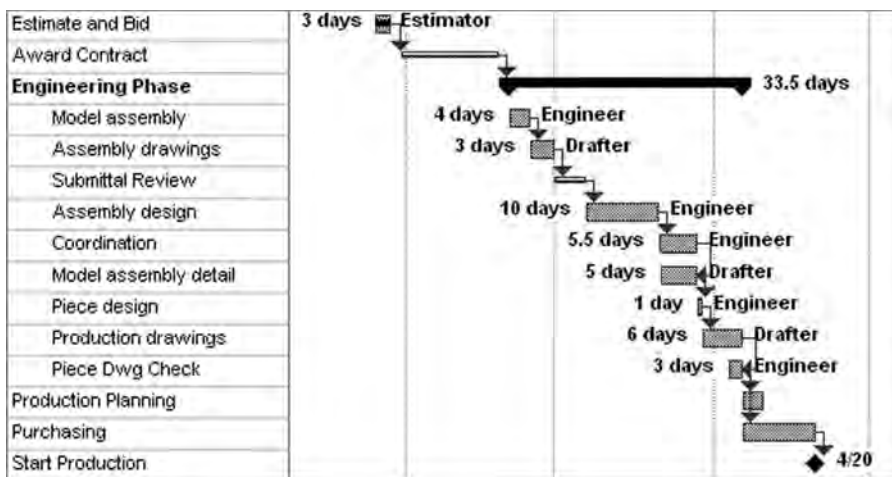
These benefits derive from the high degree of automation that BIM systems are capable of achieving, when attempting to generate and communicate detailed fabrication and erection information. Parametric relationships between building model objects (that implement basic design knowledge) and their data attributes (that enable systems to compute and report meaningful information for production processes) are the two features of BIM systems that make these improvements possible. This technology is reviewed in further detail in Chapter 2.

A reduction in cycle time can be achieved by exploiting automation for the production of shop drawings. The extent of this benefit has been explored in numerous research projects. In the structural steel fabrication industry, fabricators reported almost a 50 percent savings in time for the engineering detailing stage (Crowley 2003). The General Motors Production Plant case study, reported in the first edition of this book (Chapter 9), documented a project with a 50 percent reduction of overall design-construction time compared to traditional design-bid-build projects (although some of this reduction can be attributed to the lean management and other technologies that were used in addition to 3D models of the structural steel). An early but detailed evaluation of lead-time reduction in the case of architectural precast concrete façade panels was performed within the framework of a research project initiated by a consortium of precast concrete companies (Sacks 2004). The first Gantt chart in Figure 7–2 shows a baseline process for engineering the design of an office building’s façade panels. The benchmark represents the shortest theoretical

**FIGURE 7-2**

(Top) A benchmark of production lead time for engineering design and detailing of architectural precast façade panels using 2D CAD; and (Bottom) an evaluation of a comparable lead time using 3D parametric modeling (Sacks 2004).

Reproduced from the *Journal of Computing in Civil Engineering* 18(4), by permission of the American Society of Civil Engineers.



duration of the project using 2D CAD, if work had been performed continuously and without interruption. The benchmark was obtained by reducing the durations measured for each activity in the actual project to the net number of hours that the project team worked on them. The second Gantt chart shows an estimated timeline for the same project, if performed using an available 3D parametric modeling system. In this case, the reduction in lead time decreased from the baseline minimum of 80 working days to 34 working days.

### 7.3.3 Reduced Design Coordination Errors

In the introduction to this chapter, we mentioned the need for fabricators to communicate construction intent to designers. One of the reasons for this is that the information obtained through the submittal and approval process is essential to the design team as a whole. It allows the team to identify potential

conflicts inherent in the design. A physical clash between two components, where they are destined to occupy the same physical space, is the most obvious problem. It is termed a hard clash. Soft clashes occur when components are placed too close to one another, albeit not in physical contact, such as rebar that are too close to allow for the proper placing of concrete or pipes that require adequate space for insulation. Soft clashes are sometimes referred to as clearance clashes. Logical clashes are a third type, and include constructability problems, where certain components obstruct the construction or erection of other components, and access problems, where access needed for operation, service, or dismounting of equipment is obstructed.

When design coordination is incomplete—in any given situation—the conflicts are discovered during installation of the second component. Regardless of who carries the legal and fiscal liability for the resulting rework and delays, the fabricators inevitably suffer. Construction is leaner when work is predictable and uninterrupted.

BIM offers numerous technical benefits that improve design coordination at all stages. Of particular interest to fabricators is the ability to create integrated models of potentially conflicting systems at production-detail levels. A common tool for conflict detection is Autodesk Navisworks Manage software (Navisworks 2010), which imports models from various platforms into a single environment for identifying physical clashes. The clashes are identified automatically and reported to the users (this application is discussed in Chapter 6 and is apparent in the Sutter Medical Center case study presented in Chapter 9).

Current technology limitations prevent the resolution of clashes directly using this system. Technically, it is not possible to make corrections in the integrated environment and then port them back to the originating modeling environments. Once the team has decided upon a solution for a conflict identified in the review software, each trade must then make the necessary changes within their individual BIM software. Repeating the cycle of importing the models to the review software enables close to real-time coordination, especially if the detailers for the trades are colocated, as they were in the Sutter Medical Center case study discussed below. In future systems it should be possible to report the clash back to each trade's native BIM tool by using the component IDs (see Chapter 3 for a detailed explanation of these interoperability issues).

To avoid design coordination conflicts, the best practice is for detailed design to be performed in parallel and within collaborative work environments involving all of the fabricating trades. This avoids the almost inevitable need for rework in the detailed design, even when conflicts in the completed designs

have already been identified and resolved. Essentially, this was the process adopted in the Sutter Medical Center project by DPR Construction and its trade subcontractor partners (see Chapter 9). Detailers for plumbing, HVAC, sprinkler systems, electrical conduits, and other systems were collocated in a site office and detailed each of their systems in close proximity with one another and in direct response to the progress of fabrication and installation of the systems onsite. Almost no coordination errors reached the jobsite itself.

Another significant waste occurs when inconsistencies appear within the fabricator's own drawing sets. Traditional sets, whether drawn by hand or using CAD, contain multiple representations of each individual artifact. Designers and drafters are required to maintain consistency between the various drawings as the design development progresses and further changes are made. Despite quality control systems of various kinds, entirely error-free drawing sets are rare. A detailed study of drawing errors in the precast concrete industry, covering some 37,500 pieces from various projects and producers, showed that the costs of design coordination errors amount to approximately 0.46 percent of total project costs (Sacks 2004).

Two views of drawings of a precast concrete beam are shown in Figure 7-3. They serve as a good example of how discrepancies can occur. Figure 7-3 (Top) shows a concrete beam in an elevation view of the outside of the building; and Figure 7-3 (Middle) shows the same beam in a piece fabrication shop drawing. The external face of the beam had brick facing, which is fabricated by placing the bricks face down in the mold. The shop drawing should have shown the back of the beam up, for instance, with the bare concrete (internal to the building) face-up in plan view. Due to a drafting oversight, the inversion was not made and the beam was shown with the external face up, which resulted in all eight beams in this project being fabricated as “mirror images” of the actual beams needed. They could not be erected as planned—see Figure 7-3 (Bottom)—which resulted in expensive rework, reduced quality, and construction delays.

### 7.3.4 Lower Engineering and Detailing Costs

BIM reduces direct engineering costs in three ways:

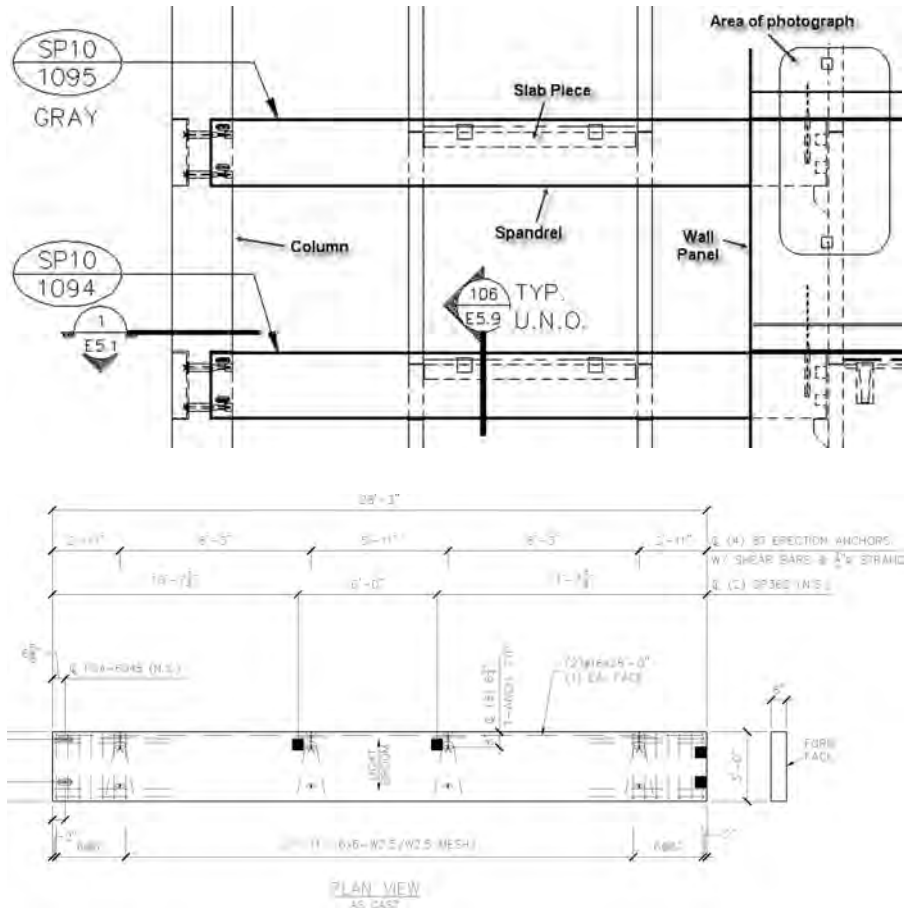
- Through the increased use of automated design and analysis software
- Almost fully automated production of drawings and material takeoffs
- Reduced rework due to enhanced quality control and design coordination

One major difference between BIM and CAD is that building information objects can be programmed to display seemingly “intelligent” behaviors. This

**FIGURE 7-3**

Drawing inconsistency for a precast concrete spandrel beam: (Top) elevation, (Middle) piece fabrication shop drawing drawn in mirror image in error, and (Bottom) the beams in place with mismatched end connection details.

(Sacks et al. 2003) Reproduced from the *Journal of the Precast/ Prestressed Concrete Institute* 48(3), with permission of the Precast/Prestressed Concrete Institute.



means that the preprocessing of data for analysis software of various kinds, from thermal and ventilation analyses to dynamic structural analyses, can be performed directly from BIM data or within the BIM platform itself. For example, most BIM platforms used for structural systems enable the definition of loads, load cases, support conditions, material properties, and all other data needed for structural analyses, such as finite element analysis.

It also means that BIM systems can allow designers to adopt a top-down design development approach, where the software propagates the geometric implications of high-level design decisions to its constituent parts. For example, the fine details of shaping pieces to fit to one another at connections can be carried out by automated routines based on premade custom components. The work of detailing the designs for production can, to a large extent, be automated. Apart from its other benefits, automated detailing directly reduces the number of hours that must be consumed to detail ETO components and to produce shop drawings.

Most BIM systems produce reports, including drawings and material take-offs, in a highly automated fashion. Some also maintain consistency between the model and the drawing set without explicit action on the part of the operator. This introduces savings in the number of drafting hours needed, which is particularly important to fabricators who previously spent the lion's share of their engineering hours on the tedious task of preparing shop drawings.

Various estimates of the extent of this direct productivity gain for engineering and drafting with the use of BIM have been published (Autodesk 2004; Sacks 2004), although few recorded measurements are available. One set of large-scale experiments was undertaken for the case of preparing construction drawings and detailing rebar for cast-in-place reinforced concrete structures using a BIM platform with parametric modeling, customizable automated detailing routines, and automated drawing preparation (Sacks and Barak 2007). The buildings had previously been detailed using 2D CAD, and the hours worked were recorded. As can be seen in Table 7–2, the reduction in engineering and drafting hours for the three case study projects fell in the range of 21 to 61 percent. (Figure 7–4 shows axonometric views of the three cast-in-place reinforced concrete structures modeled in the study.)

### **7.3.5 Increased Use of Automated Manufacturing Technologies**

Computer numerically controlled (CNC) machinery for various ETO component fabrication tasks has been available for many years. Examples include: laser cutting and drilling machines for structural steel fabrication; bending and cutting machines for fabricating reinforcing steel for concrete; saws, drills, and laser

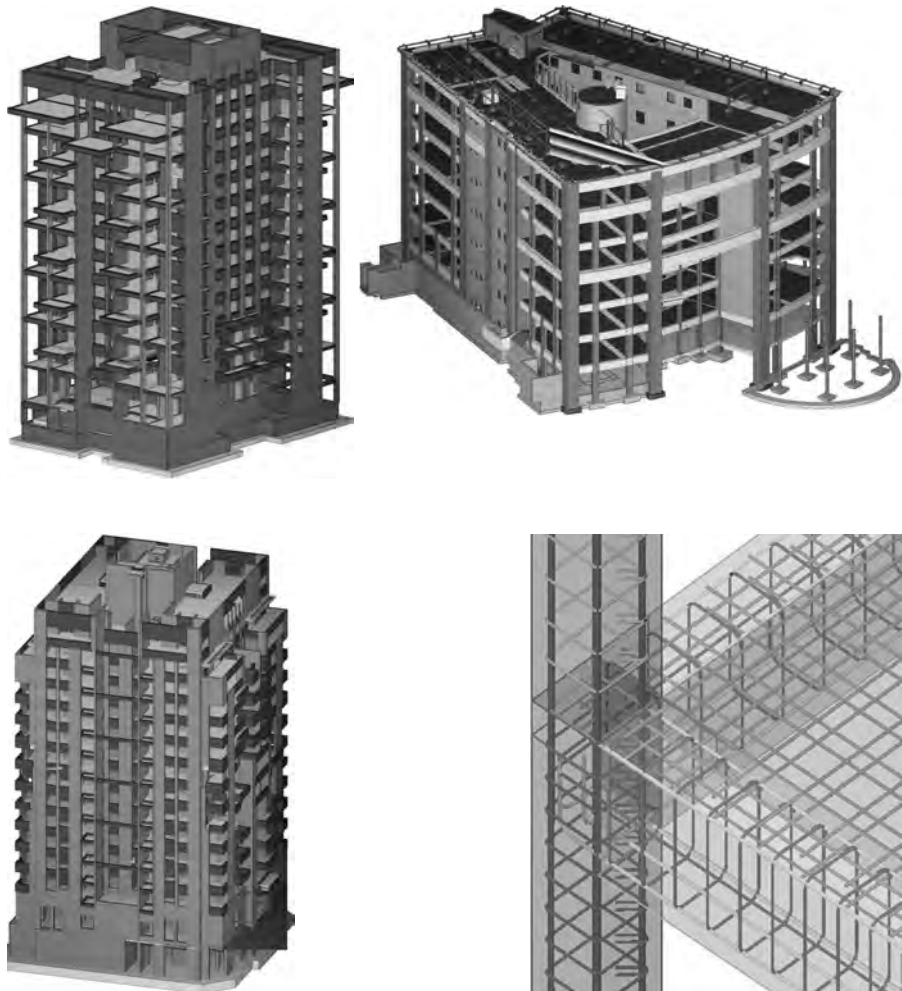
**Table 7-2** Experimental Data for Three Reinforced Concrete Building Projects

Hours Worked	Project A	Project B	Project C
Modeling	131	191	140
Reinforcement detailing	444	440	333
Drawing production	89	181	126
Total 3D	664	875	599
Comparative 2D hours	1,704	1,950	760
Reduction	61%	55%	21%

**FIGURE 7-4**

Axonomic views of projects A, B, and C.

These models, prepared as part of an experiment to evaluate 3D modeling productivity, contain complete rebar details. The close-up image shows detailed rebars in a balcony slab and supporting beams.





projectors for timber truss manufacture; water jet and laser cutting of sheet metal for ductwork; pipe cutting and threading for plumbing; as well as others. However, the need for human labor to code the computer instructions that guide these machines proved to be a significant economic barrier to their use.

Two-dimensional CAD technology provided a platform for overcoming data input barriers by allowing third-party software providers to develop graphic interfaces, where users could draw the products rather than coding them alphanumerically. In almost every case, the developers found it necessary to add meaningful information to the graphics that represented the pieces to be fabricated by creating computable data objects that represented building parts. They could then automatically generate parts and material takeoffs, resulting in what might be called “building part information modeling” applications.

The parts, however, continued to be modeled separately for each fabrication stage. When changes were made to building systems, operators had to manually revise or reproduce the part model objects to maintain consistency. Apart from the additional time required, manual revision suffers the drawback that inconsistencies may be introduced. In some cases, such as for the structural steel fabrication industry, software companies addressed this problem by developing top-down modeling systems for updating within assemblies and parts, so that a change would propagate almost entirely automatically to the affected pieces. These developments were constrained to certain sectors, such as the structural steel industry, where market size, the scale of economic benefit from use of the systems, and technological advances made investment in software development economically viable. These applications evolved into fully object-oriented 3D parametric modeling systems.

BIM platforms model every part of a building using meaningful and computable objects, and so provide information from which the data forms required for controlling automated machinery can be extracted with relative ease. Unlike their 2D CAD-based predecessors, however, they also provide the logistical information needed for managing the fabrication processes, including links to construction and production schedules, product tracking systems, and so forth.

### **7.3.6 Increased Preassembly and Prefabrication**

By removing or drastically reducing the overhead effort required to produce shop drawings, BIM platforms make it economically feasible for companies to prefabricate a greater variety of pieces for any building project. Automatic maintenance of geometric integrity means that making a change to a standard piece and producing a specialized shop drawing or set of CNC instructions demands relatively little effort. More structurally diverse buildings, such as the Walt Disney Concert Hall in Los Angeles (Post 2002) or Dublin’s Aviva Stadium

(Chapter 9), become possible and increasingly more of the standard parts of buildings can be prefabricated economically.

The trend toward prefabrication is encouraged by the relative reduction in risk associated with parts not fitting properly when installed. Each trade's perception of that risk, or of the reliability of the design as a whole, is strongly influenced by the knowledge that all other systems are similarly and fully defined in 3D and reviewed together. This is true not only for prefabricated modular parts, but also for simpler, linear building systems. Because the cost of detailing and coordinating the layout of many routed systems (such as pipes and electrical trays) using 2D drawings was prohibitive, they were often simply routed onsite. Each subsequent contractor would have a more difficult job routing their system as ceiling space became occupied. Parametric 3D modeling of all building systems, with coordinated resolution of space conflicts, allocates and guarantees space reservations for each participating system.

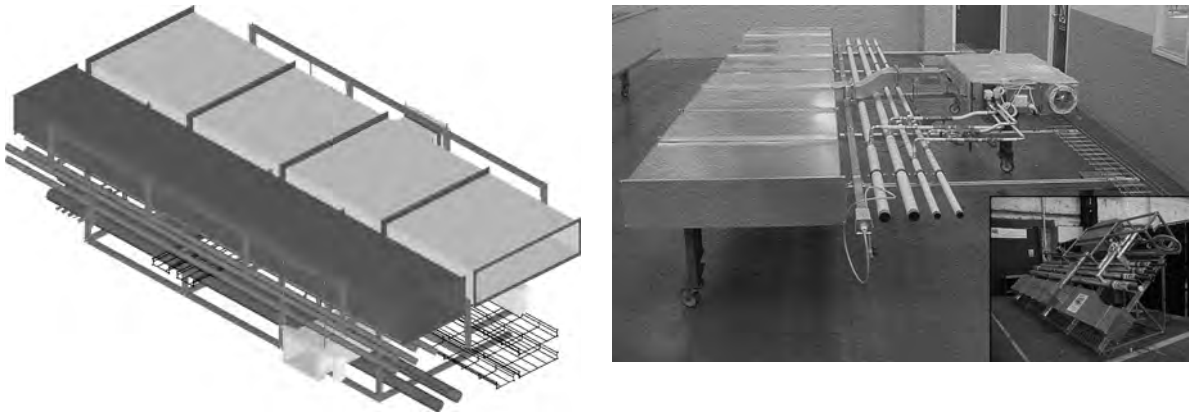
With few exceptions, 2D CAD did not give rise to new fabrication methods,<sup>4</sup> and it did little to aid the logistics of prefabrication offsite. BIM, on the other hand, is already enabling not only greater degrees of prefabrication than could be considered without it but also prefabrication of building parts that were previously assembled onsite. Because BIM supports close coordination between building systems and trades, integrated prefabrication of building modules that incorporate parts of multiple systems is now feasible. For example, Crown House Technologies, a U.K. MEP contractor, has developed a sophisticated system for hospital projects in which large sections of pipes and plumbing fixtures are preassembled on stud frames and then rolled into place. Construction of the Staffordshire Hospital in the United Kingdom provided an excellent example (Court et al. 2006; Pasquire et al. 2006). Figure 7-5 shows how components of HVAC, plumbing, sprinkler, electrical, and communication systems can be assembled together in a module for simple installation in the ceiling of a corridor onsite. Coordinating the physical and logistical aspects of integration to this degree is only possible given the richness and reliability of the information provided by BIM.

### **7.3.7 Quality Control, Supply Chain Management, and Lifecycle Maintenance**

Numerous avenues for applying sophisticated tracking and monitoring technologies in construction have been proposed and explored in various research

---

<sup>4</sup> One notable exception is the BAMTEC system in which entire carpets of rebar, with customized bar diameters and lengths, are welded together and brought to site in rolls.



**FIGURE 7-5** Prefabricated ceiling services modules with parts of HVAC, electric, and plumbing systems all installed together. (Left) Shows a 3D model view (Court et al. 2006) and (Right) shows factory prototypes (Pasquire et al. 2006).

Images courtesy of Crown House Technologies, Laing O'Rourke, UK.

projects. They include: the use of radio-frequency ID (RFID) tags for logistics; comparing as-built structures to design models with laser scanning (LADAR); monitoring quality using image processing; and reading equipment “black box” monitored information to assess material consumption. Many more are described in the “Capital Projects Technology Roadmap” devised by FIATECH (FIATECH 2010).

RFID tracking for ETO components has moved from research to practice, with significant success reported in numerous projects. The Meadowlands Stadium project built by Skanska in New Jersey, is an excellent example (Sawyer 2008). Some 3,200 precast concrete components were tracked through fabrication, shipment, erection, and quality control using RFID tags read by field staff using rugged tablet PCs. The tag IDs corresponded with the virtual objects in the building model, which allowed clear visualization and reporting of the status of all precast pieces. Figure 7-7(B) shows a screen shot of the Tekla model in a Web viewer, with color-coding of the pieces as recorded using software and hardware provided by Vela Systems. The major benefit is that day-to-day operational decisions that have far-reaching cost implications can be made on the basis of clear, accurate, and up-to-date information.

The Maryland General Hospital project, which is reported in Chapter 9, shows how barcode tags used for tracking during construction became an invaluable asset for lifecycle maintenance of major mechanical and electrical equipment. DPR Construction’s successful use of the same technology for

tracking doors and frames in the UCSC Porter B College project is yet another example.

For manufacturers of ETO products for construction, three main areas of application will be:

- Monitoring of the production, storage, delivery to the site, installation location, and quality control of components using GPS and RFID systems
- Supporting the installation or erection of components and quality control using LADAR and other surveying technologies
- Providing lifecycle information about components and their performance using RFID tags and sensors

A common thread that runs through all of these proposed systems is the need for a building model to carry the information against which monitored data can be compared. The quantity of data that is typically collected by automated monitoring technologies is such that sophisticated software is required to interpret them. For this interpretation to be meaningful, both the designed state of the building product and the as-built realization, involving both geometry and other product and process information, must be available in a computer-readable format.

---

## 7.4 BIM-ENABLED PROCESS CHANGE

As we have described in earlier chapters, BIM's primary contribution for general contractors, subcontractors, and fabricators is that it enables *virtual* construction. From the perspective of those directly responsible for producing buildings, whether onsite or in offsite fabrication facilities, this is not just an improvement but a new way of working. For the first time, construction managers and supervisors can practice putting the pieces together before they actually commit to the labor and materials. They can explore product and process alternatives, make changes to parts, and adapt the construction procedures in advance. And they can perform all of these activities in close collaboration with one another across different trades continuously and as construction progresses, allowing them to cope with unforeseen situations as they emerge. They can also deal in this same way with changes introduced by owners and designers.

Despite the fact that BIM platforms and applications, as a whole, are not yet mature enough to make virtual construction simple and commonplace, best practices by leading construction teams throughout the world are already resulting in the process changes described below. Some construction companies

have already developed a strong track record of projects in which they achieved a high degree of coordination among all of a project's fabrication and erection partners. Teams, such as those engaged in the Sutter Medical Center and the Crusell Bridge project (Chapter 9) or the GM Production Plant projects (see Eastman et al. 2008) have continued to refine their methods. They succeeded in those projects, not because they were expert at operating any one or other software, but as a result of the integrated way they exploited BIM technology to build virtually and in a collaborative fashion early in the project.

### 7.4.1 Leaner Construction

In the manufacturing world, lean production methods evolved to meet individual clients' demands for highly customized products, without the waste inherent in traditional methods of mass production (Womack and Jones 2003). In general, the principles developed apply to any production system, but given the differences between production of consumer products and building construction, adaptation of the manufacturing implementations was needed.

Lean construction is concerned with process improvement, so that buildings and facilities may be built to meet the clients' needs while consuming minimal resources. This requires thinking about how work *flows*, with an emphasis on identifying and removing obstacles and bottlenecks. Lean construction places special focus on workflow stability. A common cause of long construction durations are the long buffer times introduced by subcontractors to shield their own productivity where quantities of work made available are unstable and unpredictable. This occurs because subcontractors are reluctant to risk wasting their crews' time (or reducing their productivity) in the event that other subcontractors fail to meet their commitments to complete preceding work on time, or in case materials are not delivered when needed, or design information and decisions are delayed, and so forth.

One of the primary ways to expose waste and improve flow is to adopt *pull flow control*, in which work is only performed when the demand for it is made apparent downstream in the process, with the ultimate pull signal provided at the end of the process by the client. Workflow can be measured in terms of the overall cycle time for each product or building section, the ratio of activities that are completed as planned, or the inventory of work in progress (known as "WIP"). Waste is not only material waste but process waste: time spent waiting for inputs, rework, and the like.<sup>5</sup>

---

<sup>5</sup> Readers interested in a brief introduction to the concepts of lean thinking are referred to the work of Womack and Jones (2003); references and links to the extensive literature on the subject of lean construction specifically can be found at the Web site of the International Group for Lean Construction ([www.iglc.net](http://www.iglc.net)).

BIM facilitates leaner construction processes that directly impact the way subcontractors and fabricators work in four ways:

- 1. Greater degrees of prefabrication and preassembly** driven by the availability of error-free design information resulting from virtual construction (the ways in which BIM supports these benefits are described in Section 7.3.5) translates to reduced duration of onsite construction and a **shortened product cycle time** from the client's perspective. Increased prefabrication also leads to enhanced safety as more work, much of which was previously done at height, is moved from the site to factory conditions.
- 2.** Sharing models is not only useful for identifying physical or other design conflicts; shared models that are linked to planned installation timing data using 4D CAD techniques enable exploration of construction sequences and interdependencies between trades. Careful planning of production activities at the weekly level is a key tenet of lean construction. It is commonly implemented using the "Last Planner™" system (Ballard 2000), which filters activities to avoid assigning those which may not be able to be carried out correctly and completely. Thus, a priori identification of spatial, logical, or organizational conflicts through step-by-step virtual construction using BIM *improves workflow stability*.
- 3. Enhanced teamwork:** the ability to coordinate erection activities at a finer grain among different trades means that traditional interface problems—involving the handover of work and spaces from team to team—are also reduced. When construction is performed by better integrated teams, rather than by unrelated groups, fewer and shorter time buffers are needed.
- 4.** When the gross time required for actual fabrication and delivery is reduced—due to the ability to produce shop drawings faster—fabricators are able to reduce their lead times. If lead times can be reduced far enough, then fabricators will be able to reconfigure their supply to sites more easily to take advantage of the improved pull flow. This extends beyond just-in-time delivery to just-in-time production, a practice that substantially *reduces inventories of ETO components* and their associated waste: costs of storage, multiple-handling, damaged or lost parts, shipping coordination, and so forth. Also, because BIM systems can generate reliable and accurate shop drawings at the last responsible moment—even when late changes are made—fabricators of all kinds can be more responsive to clients' needs, because pieces are not produced too early in the process.

### 7.4.2 Less Paper in Construction

When CAD was adopted initially, electronic transfers became a partial alternative to communicating paper drawings. The more fundamental change that BIM introduces is that drawings are relegated from the status of information archive to that of communicating medium, whether paper or electronic. In cases where BIM serves as the sole reliable archive for building information, paper printouts of drawings, specifications, quantity takeoffs, and other reports primarily serve to provide more easily legible access to the information.

For fabricators exploiting automated production equipment, as described in Section 7.3.5, the need for paper drawings largely disappears. For example, parts of timber trusses that are cut and drilled using CNC machines are efficiently assembled and joined on beds, where the geometry is projected from above using laser technology. Productivity for the assembly of complex rebar cages for precast concrete fabrication improves when the crew consults a color-coded 3D model, which they can manipulate at will on a large screen, instead of interpreting traditional orthogonal views on paper drawings. The delivery of geometric and other information to structural steel erectors onsite using PDAs that graphically display 3D VRML models of steel structures (translated from CIS/2 models by NIST's software) is a similar example (Lipman 2004).

The need for paper reports is greatly reduced as information from BIM fabrication models begins to drive logistics, accounting, and other management information systems and is aided by automated data collection technologies. It is, perhaps, only the slow pace of legal and commercial change that prevents this section from being titled "Paperless Construction."

### 7.4.3 Increased Distribution of Work

The use of electronic building models means that communication over long distances is no longer a barrier to the distribution of work. In this sense, BIM facilitates increased outsourcing and even globalization of two aspects of construction work that were previously the domain of local subcontractors and fabricators.

First, it is possible for design, analysis, and engineering to be carried out more easily by geographically and organizationally dispersed groups. In the structural steel industry, it is becoming commonplace for individuals, armed with powerful 3D parametric detailing software, to become freelancers providing services to fabricators that have greatly reduced their in-house engineering departments. Outsourcing of 3D modeling and plant engineering work to India in sectors like aerospace, automotive, and industrial machinery is already common.

Second, better design coordination and communication means that fabrication itself can be outsourced more reliably, including shipping parts over

long distances. In the case study describing the building at 100 11th Avenue in New York City (Chapter 9), accurate BIM information enabled the production of façade components in China for installation in New York City.

---

## 7.5 GENERIC BIM SYSTEM REQUIREMENTS FOR FABRICATORS

In this and the following section, we define the system requirements that ETO component fabricators, design service providers, and consultants should require from any software platform they are considering. This section defines generic requirements common to all types of fabrication and places special emphasis on the need for fabricators to participate actively in compiling comprehensive building models as part of collaborative project teams. The following section expands the list of requirements to include specialized needs of specific types of fabricators.

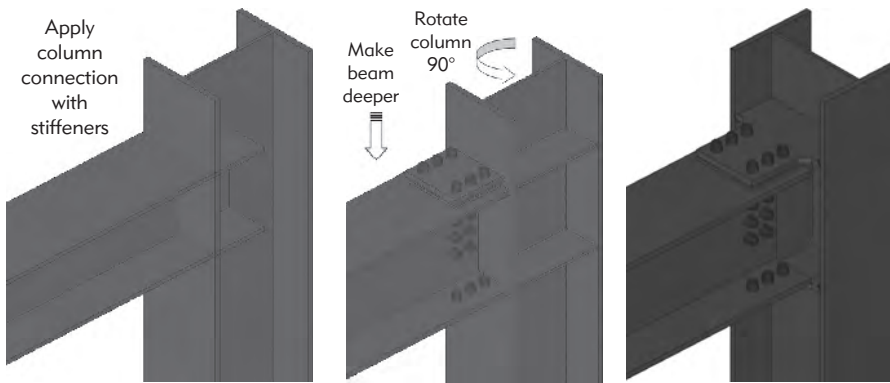
Note that the most basic required properties of BIM platforms, such as support for solid modeling, are not listed, because they are essential for all users and almost universally available. For example, the solid modeling capabilities that all fabricators require for clash detection and volumetric quantity takeoffs are provided in all BIM software because section views cannot be produced automatically without them.

### 7.5.1 Parametric and Customizable Parts and Relationships

The ability to automate design and detailing tasks to a high degree—and for building models to remain coherent, semantically correct, and accurate even as they are manipulated—are cornerstones for reaping the benefits of BIM for fabricators. Creating models would be excessively time-consuming and impractical if operators were required to generate each and every detailed object individually. It would not only be time-consuming but also highly error-prone if operators were required to actively propagate all changes from building assemblies to all of their detailed constituent components.

For these reasons, fabricators must have software systems that support parametric objects for their system and that manage relationships between objects at all levels (parametric objects and relationships are defined in Chapter 2). The structural steel connection shown in Figure 7–6 illustrates this requirement. The software selects and applies an appropriate connection according to its predefined rules. Setup and selection of rule sets for a project may be done by the engineer of record or by the fabricator, depending on the accepted practice, and may or may not include rules to respond to changes in





**FIGURE 7-6**  
Structural steel connection  
in Tekla Structures.

The software applies the connection selected by the operator (Left) to (Middle) and automatically updates the customized connection when the beam is made deeper and the column is rotated (Middle to Right).

the loads applied. If the profile shape or parameters of either of the connected members are subsequently changed, the geometry and logic of the connection updates automatically.

An important aspect to evaluate is the degree to which customized parts, details, and connections can be added to a system. A powerful system will support: nesting of parametric components within one another; modeling of geometric constraints, such as “parallel to” or “at a constant distance from”; and application of generative rules that determine whether a component will be created in any given context.

### 7.5.2 Reporting Components for Fabrication

The ability to automatically generate production reports for each individual ETO component in a building is essential for fabricators of all kinds. Reporting may include: preparation of shop drawings; compiling CNC machinery instructions; listing constituent parts and materials for procurement; specifying surface finish treatments and materials; and listing hardware required for installation onsite, and so forth.

In prefabrication of any type of ETO component, it is important to be able to group the components in different ways to manage their production (i.e., procurement of parts, preparation of forms and tools, storage, shipping, and erection). Precast concrete parts and fabricated formwork pieces for cast-in-place concrete are commonly grouped according to their molds, so that single molds can be used for multiple parts with minor modifications between each use. Reinforcing bars must be produced and bundled in groups according to their association with building elements.

To support these needs, BIM applications should be able to group components according to criteria specified by operators on the basis of their

geometric information, order of assembly, supplier, and other classifications, and also meta-data (defining origin and ownership of the data, status, and IDs). In the case of geometric shapes, the software should be able to distinguish between parts on the basis of the degree to which the pieces are similar or dissimilar. For example, timber trusses might be given a primary identifier for grouping those trusses with the same overall shape and configuration, while a secondary identifier could be used to distinguish subgroups of one or more trusses with minor differences within the primary group. If a generic truss family were given the type identifier “101,” then a subgroup of a few trusses within the generic “101 family” might include a particular member with a larger profile size that is otherwise the same as a “101” and might be named subfamily “101-A.”

In some applications, prefabricated ETO components will require that some of the constituent parts be delivered loose to the jobsite, such as weld plates for embedding in reinforced concrete elements. These too must be grouped and labeled to ensure delivery to the right place at the right time. Where parts must be cast into or bolted onto the building’s structure, they may need to be delivered in advance to other subcontractors or even to other fabricators. All of this information must be generated and applied to the objects, preferably automatically, within the BIM platform.

### **7.5.3 Interface to Management Information Systems**

A two-way interface to communicate with procurement, production control, shipping, and accounting information systems is essential in order to fully leverage the potential benefits detailed earlier in the chapter. These may be standalone applications or parts of a comprehensive enterprise resource planning (ERP) suite. To avoid inconsistencies, the building model should be the sole source for part lists and part production details for the full operation. Fabrication is performed over time, during which changes may continue to be made to the building’s design. Up-to-date information regarding changes made to pieces in the model must be available to all of a company’s departments at all times, if errors are to be avoided. Ideally, this should not be a simple file export/import exchange but an online database link. Minimally, the software should provide an application programming interface, so that companies with access to programming capability can adapt data exchanges to the requirements of their existing enterprise systems.

Where building models are integrated with other management systems, automated tracking systems for ETO components, from production through storage, delivery, erection, and operation become feasible. Systems exploiting bar-code tracking are common, while the more powerful radio-frequency identification (RFID) technology has been shown to be feasible for only some

ETO component types (Ergen et al. 2007). This technology has been successfully applied in industry, such as in the Meadowlands Stadium and other projects discussed in Section 7.3.7.

#### 7.5.4 Interoperability

By definition, subcontractors and fabricators provide only part of a building's systems. The ability to communicate information between their BIM platform and those of the designers, general contractors, and other fabricators is essential. Indeed, one may conceive of a comprehensive building model as consisting of the full set of system models maintained in the distinct BIM platforms of the numerous design and construction trades, even if there is no one unified database. No single fabrication platform is able to address all aspects of building construction fabrication today, and we do not expect this situation to change.

The technical aspects of interoperability are discussed thoroughly in Chapter 3, including both its benefits and limitations. Suffice it to say that for the purposes of BIM platform selection by subcontractors and fabricators, the capability to import and export models using an appropriate industry exchange standard should be considered mandatory. Which standard is most important depends on the industry sector: for structural steel the CIS/2 format is essential; for most other sectors the IFC format will likely be most useful.

#### 7.5.5 Information Visualization

A 3D building model view is a very effective platform for entering and visualizing management information, particularly for erectors and general contractor staff outside the fabricator's organization. Customizable functions for generating model displays that are colored according to a variety of production status data are highly beneficial.

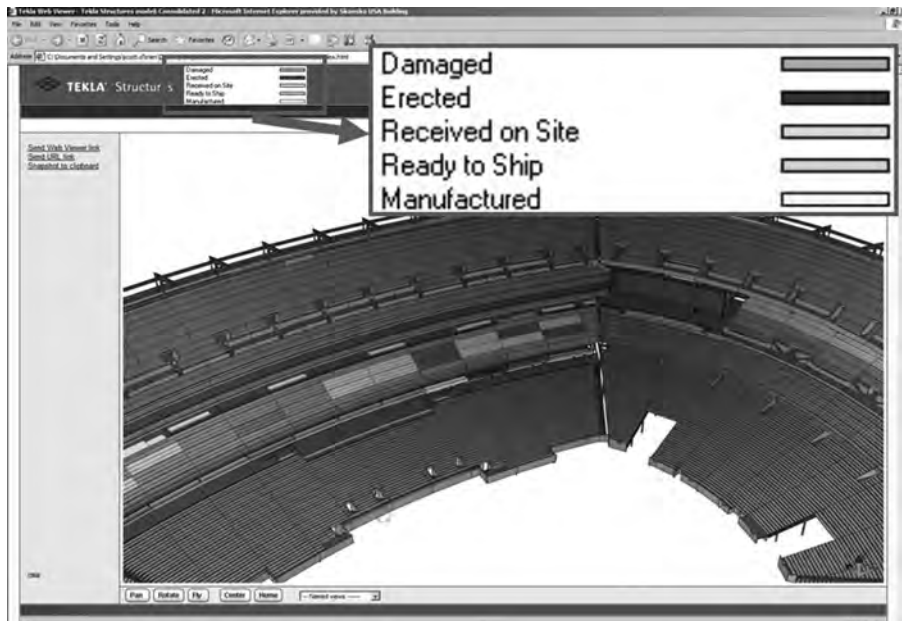
Two good examples are the use of 4D CAD techniques for micro-planning of a construction operation and the use of a model interface to pull the delivery of prefabricated parts to the jobsite in a just-in-time configuration. In the first, a building model that included the structural members and the resources (cranes) and activities was used for step-by-step planning and simulation of the erection sequence for steel and precast concrete elements for an underground subway station roof in London (Koerckel and Ballard 2005). Careful planning was essential so that the project team could meet a strict 48-hour time limit for erection, during which train traffic was suspended. For a detailed description of 4D CAD techniques and benefits, please refer to Section 7 in Chapter 6.

The second example is illustrated by Figure 7-7 (Top), which shows field personnel consulting a building model at the Meadowlands Stadium project described in Section 7.3.7. Instead of consulting a spread of drawings and

**FIGURE 7-7**

(Top) Field personnel use rugged tablet PCs to query information about precast pieces and their production, delivery, erection, and approval status from a color-coded model of the stadium. (Bottom) The PCs are equipped with readers to capture information from RFID tags attached to the precast concrete pieces. (See color insert for full color figure.)

Photos courtesy of Vela Systems, Inc. All rights reserved.



paper reports, which are often out of date, to select pieces for manufacture and delivery, project managers can plan work with high reliability. The effort of coordinating between multiple sets of drawings and lists and the resultant human errors are eliminated. Indeed, information visualization of this kind,

where a site supervisor can simply point and click on a color-coded model to compile delivery lists, as shown in Figure 7–7 (Bottom), enables the pull flow control paradigm advocated by lean construction thinking.

### 7.5.6 Automation of Fabrication Tasks

The selection of a BIM software platform should reflect the opportunities and plans for automation of the fabrication tasks. These vary with each building system. Some companies will already have CNC machines of different kinds, such as rebar bending and cutting machines, laser cutters for steel profiles or plates, or sophisticated conveyor and casting systems for precast concrete. For some fabricators, these technologies may be drivers for adopting BIM; for others, they will be new options, and BIM will enable their introduction. In either case, it is important to consider the information requirements and the interfaces that are supported by the BIM software.

---

## 7.6 MAJOR CLASSES OF FABRICATORS AND THEIR SPECIFIC NEEDS

This section describes specific requirements for fabricators of various kinds. It also provides a short list of software packages (available at the time of publication) for each class of fabricator. The software packages are listed in Table 7–3 along with explanations of their functionality for each domain and sources for additional information.

### 7.6.1 Structural Steel

With steel construction, the overall structure is divided into distinct parts that can be easily fabricated, transported to the site, erected, and joined, using minimal material quantities and labor, all under the necessary load constraints defined by the structural engineers.

Simply modeling the structure in 3D with all detailing of nuts, bolts, welds, plates, and so forth is not sufficient. The following are additional requirements that should be met by steel detailing software:

- ***Automated and customizable detailing of steel connections.*** This feature must incorporate the ability to define rule sets that govern the ways in which connection types are selected and parametrically adapted to suit specific situations in structures.
- ***Built-in structural analysis capabilities, including finite element analysis.*** Alternatively, as a minimum, the software should be able to

depict and export a structural model, including the definition of loads in a format that is readable by an external structural analysis package. In this case, it should also be capable of importing loads and reactions back to the 3D model.

- **Output of cutting, welding, and drilling instructions directly to computer numerically controlled (CNC) machinery.** This capability is being extended to include welding and assembly. Assembly requires even more extensive geometry and process information.

**Available software** (see Table 7–3): Tekla Structures, SDS/2 Design Data, StruCAD, 3d+.

**Table 7–3** BIM Software for Subcontractors and Fabricators

BIM Software	Building System Compatibility	Functionality	Source for information
Tekla Structures	Structural steel, Precast concrete, CIP reinforced concrete. Mechanical, Electrical, Plumbing, Curtain walls	Modeling, analysis preprocessing, fabrication detailing Coordination	<a href="http://www.tekla.com">www.tekla.com</a>
SDS/2 Design Data	Structural steel	Fabrication detailing	<a href="http://www.dsndata.com">www.dsndata.com</a>
StruCAD	Structural steel	Fabrication detailing	<a href="http://www.acecadsoftware.com/steel_detailing">www.acecadsoftware.com/steel_detailing</a>
Revit Structures	Structural steel, CIP reinforced concrete	Modeling, analysis preprocessing	<a href="http://www.autodesk.com/revit">www.autodesk.com/revit</a>
Revit MEP	Mechanical, Electrical, Plumbing, and piping	Modeling	<a href="http://www.autodesk.com/revit">www.autodesk.com/revit</a>
3d+	Structural steel		<a href="http://3dplus.cscworld.com/">3dplus.cscworld.com/</a>
Structureworks	Precast concrete	Modeling, fabrication detailing	<a href="http://www.structureworks.net">www.structureworks.net</a>
Revit Architecture	Curtain walls	Modeling	<a href="http://www.autodesk.com/revit">www.autodesk.com/revit</a>
aSa Rebar Software	CIP reinforced concrete	Estimating, detailing, production, material tracking, accounting	<a href="http://www.asarebar.com">www.asarebar.com</a>
Allplan Engineering	Structural steel, CIP reinforced concrete, precast concrete	Modeling, detailing rebar	<a href="http://www.allplan.com">www.allplan.com</a>
Allplan Architecture	Curtain walls	Modeling	<a href="http://www.allplan.com">www.allplan.com</a>
Catia (Digital Project)	Curtain walls	Modeling, FEM analysis, parsing production data for CNC	<a href="http://www.3ds.com">www.3ds.com</a>

<b>BIM Software</b>	<b>Building System Compatibility</b>	<b>Functionality</b>	<b>Source for information</b>
Graphisoft ArchiGlazing	Curtain walls	Modeling	<a href="http://www.graphisoft.com">www.graphisoft.com</a>
SoftTech V6	Curtain walls	Modeling and fabrication detailing	<a href="http://www.softtechnz.com">www.softtechnz.com</a>
CADPIPE Commercial Pipe	Piping and plumbing	Modeling and fabrication detailing	<a href="http://www.cadpipe.com">www.cadpipe.com</a>
CADPIPE HVAC and Hanger	HVAC ducts	Modeling and fabrication detailing	<a href="http://www.cadpipe.com">www.cadpipe.com</a>
CADPIPE Electrical and Hanger	Electrical conduits, cable trays	Modeling, detailing	<a href="http://www.cadpipe.com">www.cadpipe.com</a>
Quickpen PipeDesigner	Piping and plumbing	Modeling, fabrication detailing	<a href="http://www.quickpen.com">www.quickpen.com</a>
Quickpen DuctDedesigner	HVAC	Modeling and fabrication detailing	<a href="http://www.quickpen.com">www.quickpen.com</a>
Bentley Building Mechanical Systems	HVAC ducts and piping	Modeling	<a href="http://www.bentley.com">www.bentley.com</a>
Graphisoft MEP Modeler	HVAC ducts, piping, cable trays	Modeling	<a href="http://www.graphisoft.com">www.graphisoft.com</a>
CADmep+ FABmep+	HVAC ducts, piping	Modeling and fabrication detailing	<a href="http://www.map-software.com">www.map-software.com</a>
SprinkCAD	Fire sprinkler systems	Modeling and detailing	<a href="http://www.sprinkcad.com">www.sprinkcad.com</a>
Frameworkright Pro	Wood framing	Modeling and fabrication detailing	<a href="http://www.encina.co.uk/frameworkright_pro.html">www.encina.co.uk/frameworkright_pro.html</a>
MWF—Metal Wood Framer	Light-gauge steel and wood framing	Modeling and fabrication detailing	<a href="http://www.strucsoftsolutions.com/mwf.asp">www.strucsoftsolutions.com/mwf.asp</a>

### 7.6.2 Precast Concrete

Information modeling of precast concrete is more complex than modeling structural steel, because precast concrete pieces have internal parts (rebar, prestress strands, steel embeds), a much greater freedom in shapes, and a rich variety of surface finishes. These were among the reasons why BIM software tailored to the needs of precast concrete became available commercially much later than for structural steel.

The specific needs of precast concrete fabrication were researched and documented by the Precast Concrete Software Consortium (PCSC) (Eastman et al. 2001). The first two needs specified above (Section 7.6.1) for structural steel—automated and customizable detailing of connections and built-in

structural analysis capabilities—apply equally to precast concrete. In addition, the following requirements are specific to precast concrete:

- The ability to model pieces in a building model with geometric shapes different from the geometry reported in shop drawings. All precast pieces are subject to shortening and creep, which means their final shape is different than that which is produced. Precast pieces that are eccentrically prestressed become cambered when prestress cables are released after curing. The most complex change occurs when long precast pieces are deliberately twisted or warped. This is commonly done with long double tee pieces in parking garages and other structures to provide slopes for drainage, by setting the supports of one end at an angle to those of the other end. The pieces must be represented with warped geometry in the computer model, but they must be produced in straight prestressing beds. Therefore, they must be rendered straight in shop drawings. This requires a relatively complex geometric transformation between the assembly and the shop drawing representations of any intentionally deformed piece.
- Surface finishes and treatments cannot simply be applied to faces of parts but often have their own distinctive geometry, which may require subtraction of volume from the concrete itself. Stone cladding, brick patterns, thermal insulation layers, and so forth are all common examples. Special concrete mixes are used to provide custom colors and surface effects but are usually too expensive to fill the whole piece. As a result, the pieces may be composed of more than one concrete type, and the software must support the documentation of volumes required for each type.
- Specialized structural analyses of individual pieces—to check their resistance to forces applied during stripping, lifting, storage, transportation, and erection, which are different to those applied during their service life in a building—are required. This places special emphasis on the need for integration with external analysis software packages and an open application programming interface.
- The grouping of a precast piece's constituent parts must be done according to the timing of their insertion: cast into the unit at time of fabrication, cast into or welded onto the building foundation or structure, or supplied loose (bundled with the piece) to the site for erection.
- Output of rebar shapes in formats compatible with fabrication control software and automated bending and cutting machines.

**Available software** (see Table 7–3): Tekla Structures, Structureworks.



### 7.6.3 Cast-in-Place Reinforced Concrete

Unlike most of the systems reviewed in this chapter, cast-in-place (CIP) is inherently an onsite material and system. However, the same benefits and approach applied to other systems can also apply to CIP. Like precast concrete, cast-in-place reinforced concrete has internal components that must be modeled in detail. All of the requirements for structural analysis, generating and reporting rebar shapes for production and placing, and for measuring concrete volumes, are equally valid for cast-in-place concrete.

CIP concrete, however, is quite different from both structural steel and precast concrete, because cast-in-place structures are monolithic. They do not have clearly defined physical boundaries between components, such as with columns, beams, and slabs. Indeed, whether the concrete volume at the components' intersection is considered part of one or part of the other component's joint framing is determined based on the reporting needs. Revit Structures' *join geometry* feature begins to address this need, and for standard cases parameters that give one element type priority over another can be set to automate this behavior (such as setting beams to always be shortened where they intersect with columns).

Likewise, the same rebars may fulfill a specific function within one member and a different function within a joint, such as with top steel in a continuous beam that serves for shear and crack resistance within the span but also as moment reinforcement over the support.

Another difference is that cast-in-place concrete can be cast with complex curved geometries, with curvature in one or two axis directions and variable thicknesses. Although nonuniform multicurved surfaces are rare, domes are not uncommon. Any company that encounters curved concrete surfaces in its construction projects should ensure that the descriptive geometry engine of any modeling software can model such surfaces and the solid volumes they enclose.

A third difference is, unlike steel and precast components, that CIP concrete structures are partitioned differently for analysis and design than for fabrication. The locations of pour stops are often determined in the field and do not always conform to product divisions, as envisioned by the designers. Nevertheless, if the members are to be used for construction management as well as for design, they must be modeled both ways (Barak et al. 2009).

Each of these scenarios requires a different multiview approach to modeling objects than is available in most BIM software packages that currently offer some functionality for CIP concrete modeling. The ability to switch between distinct but internally consistent representations of 3D concrete geometry and idealized members for structural analysis, as provided in Revit Structures, is an important capability.

Lastly, CIP concrete requires layout and detailing of formwork, whether modular or custom designed. Some modular formwork manufacturing companies do provide layout and detailing software, which allows users to graphically apply standard formwork sections to CIP elements in 3D. The software then produces the detailed bills of material required and the drawings to aid laborers in erecting the modular forms. “ELPOS” and “PERI CAD,” provided by PERI of Germany, are two examples ([www.peri.de/ww/en/pub/company/software/elpos.cfm](http://www.peri.de/ww/en/pub/company/software/elpos.cfm)). Unfortunately, the existing applications are based on CAD software representations, mostly using 2D views. The suppliers are more likely to provide BIM-integrated solutions as demand grows.

**Available software** (see Table 7–3): Tekla Structures, Revit Structures, aSa Rebar Software integrated with Microstation, Nemetschek Allplan Engineering.

#### 7.6.4 Curtain Walls and Fenestration

Curtain walls include any wall closing system that does not have a structural function in that it does not carry gravity loads to the foundations of a building. Among custom-designed and fabricated curtain walls—essentially involving ETO components—aluminum and glass curtain walls are typical. They can be classified as *stick systems*, *unit systems*, or *composite systems*. In this chapter, *fenestration* includes all window units that are custom-designed for fabrication and installation in a specific building, with profiles of steel, aluminum, timber, plastic (PVC), or other materials.

*Stick systems* are built in-situ from metal profiles (usually aluminum), which are attached to the building frame. They are similar to structural steel frames in that they are composed of longitudinal extruded sections (vertical mullions and horizontal transoms) with joints between them. Like precast façade panels, their connections to the structural frame must be detailed explicitly for every context. They place a unique requirement on modeling software, because they are highly susceptible to changes in temperature, which cause expansion and contraction; as such, their joints must be detailed to allow for free movement without compromising their insulating or aesthetic functions. Joints with appropriate degrees of freedom and sleeves to accommodate and hide longitudinal movement are common. Stick systems require only assembly modeling, with minimal piece fabrication detailing (needed only to support cutting profiles to the right length in the shop). The ability to plan erection sequences in order to accommodate tolerances is critical.

*Unit systems* are composed of separate prefabricated pieces installed directly onto the building’s frame. A key feature for modeling is the need for high accuracy in construction, which means that dimensional tolerances for the building’s structural frame should be modeled explicitly.

*Composite systems* include unit and mullion systems, column cover and spandrel systems, and panel (strong back) systems. These require not only detailed assembly and piece fabrication details but must also be closely coordinated with a building's other systems.

Curtain walls are an important part of any building model, because they are central to all analyses of building performance other than overall structural analysis (i.e., thermal, acoustic, and lighting). Any computer simulation that can be performed on a model will need the relevant physical properties of the curtain wall system and its components—not only its geometry. Models should also support local wind and dead load structural analyses for the system components.

Most curtain wall modeling routines that are commonly available in architectural BIM systems allow for preliminary design only and have no functionality for detailing and fabrication. The 100 11th Avenue, New York, case study in Chapter 9, which presents a complex curtain wall designed for a residential building, serves as a good example of this type of use. On the other hand, software applications are available for detailing and estimating the curtain wall and fenestration systems of numerous fabricators. These applications, such as the DeMichele Group and Fenestsoft packages, are intended for modeling individual windows or curtain wall sections, without compiling them into whole building models. Due to the nature of the steel and aluminum profiles used in most curtain walls, some companies have found mechanical parametric modeling platforms, such as Solidworks and Autodesk Inventor, to be more useful.

**Available software** (see Table 7–3): Digital Project (Catia), Tekla Structures, Revit Building, Allplan Architect, Graphisoft ArchiGlazing, SoftTech V6.

### 7.6.5 Mechanical, Electrical, and Plumbing

Three distinct types of ETO component systems are included in this category: ducts and machinery for HVAC systems; piping runs for liquid and gas supply and disposal; and routing trays and control boxes for electrical and communication systems. These three systems are similar both in nature and in the space they occupy within a building, but they also depend on specific requirements for detailing and fabrication software.

Ducts for HVAC systems must be cut from sheet metal sections, fabricated in units that can be conveniently transported and maneuvered into position, and then assembled and installed in place at a building site. Duct units are three-dimensional objects and often have complex geometries. Chillers, pumps, diffusers, and other machinery have strict space and clearance requirements and interface with both electrical and plumbing systems—their locations and orientations demand careful coordination.

Piping for supply and disposal of various liquids and gases is composed of extruded profiles that also incorporate valves, bends, and other equipment. While not all piping is engineered to order, sections that require cutting, threading, or other treatments must be done in a workshop prior to delivery to be considered ETO components. In addition, spools of piping components that are preassembled as complete units prior to delivery and/or installation are also considered pre-engineered, even if most or all of their constituent parts are off-the-shelf components.

Although electrical and communication cables are largely flexible, the conduits and trays that carry them may not be, which means their layout must be coordinated with other systems.

The first and most generic requirement for these systems to be supported by BIM is that their location, orientation, and routing in space must be carefully coordinated. Routing requires easy-to-follow or color-coded visualization and functions for identifying clashes between systems. Figure 7–8, which was prepared by a general contractor (the Mortenson Company) for coordination purposes, is an excellent example of how a building's MEP systems can be modeled, checked, and prepared for fabrication, production, and installation.

Although physical clash detection is available in most piping and duct software, in many cases soft clash detection is also needed. Soft clash detection refers to certain requirements, where minimum clear space must be maintained between different systems, such as the minimum distance between a hot

**FIGURE 7–8**

A model view showing a building's MEP systems with transparent building structure components, prepared by a general contractor (Mortenson) for construction coordination. (See color insert for full color figure.)

Image provided courtesy of Mortenson.



water pipe and electrical cables. Similarly, a piece of equipment may need to be dismantled for inspection or repair, so that the path for access to it and for its removal must be kept free of interference. The software must allow users to set up rules that define verifiable spatial constraints between different pairs of systems when clash checks are performed.

A second generic requirement is the grouping of objects for production and installation logistics. Numbering or labeling components must be performed on three levels: a unique part ID for each piece; a group ID for installation spools; and a production group ID that the system assigns based on the collection of identical or largely similar parts for fabrication or procurement. Grouping of parts for site delivery, with collections of separate components belonging to duct runs and pipe spools, is particularly important. If any part is missing or cannot fit into place due to dimensional changes or fabrication errors, productivity degrades and the workflow is disrupted. To avoid this, BIM systems must provide material takeoff lists and seamless integration with logistics software for labeling schemes to allow complete and correct collections of parts to be pulled to the work-face at the right time. One technology for aiding this is the use of bar codes to track pipe spools and duct sections. A less mature method is the use of radio frequency identification (RFID) tags.

Unique BIM requirements for each of the systems are as follows:

- Most duct sections are fabricated from flat sheet metal. Software should generate cutting patterns—unfolded from 3D geometric shapes—and translate the data into a format appropriate for plasma cutting tables or other machinery. The software should also offer optimization of the nesting pattern to minimize off-cut waste.
- Piping spools are commonly represented in symbolic isometric drawings. Software should enable display in multiple formats, including full 3D representation, line representation, and symbolic form, as well as 2D plans, sections, and isometric views. In addition, it should automatically generate spool assembly drawings with bill of material data.

Software applications capable of generating detailed models and fabrication information for MEP systems were made available earlier than for other building systems. This was mainly because ducts, pipes, and the like, are generally composed of distinct parts, which have standard geometries that are independent of local conditions at the interfaces between parts. Solid modeling and Boolean operations were not needed, and self-contained parametric parts could be added by programming purpose-built routines. It was therefore possible to provide fabrication-level modeling on the basis of generic CAD

software, which lacked more sophisticated parametric and constraint modeling capabilities.

The drawback of CAD-based applications, as opposed to BIM-based applications, is that CAD platforms do not maintain logical integrity when changes are entered. Neighboring duct sections should adjust when changes are made to individual sections or to a duct run as a whole. When a duct or pipe that penetrates a slab or wall moves, the hole in the slab or wall should either also be moved or healed if it is no longer needed. Some MEP applications lack the import and export interfaces needed for industrywide interoperability, such as support for IFC models.

Subcontractors and fabricators are likely to continue using CAD-based platforms, such as those listed below, because the BIM software packages that offer MEP capabilities—such as Revit Systems and Bentley Building Mechanical Systems—do not extend to the production of detailed fabrication drawings. This “mixed use” is apparent in the Sutter Medical Center case study (Chapter 9). For this reason, it is important to ensure that any CAD-based platform is capable of supporting file formats that can be uploaded into design coordination programs like Autodesk Navisworks Manage (Navisworks 2010).

**Available software** (see Table 7–3): Quickpen (PipeDesigner and DuctDesigner), CADPIPE (HVAC, Commercial Pipe, Electrical, Hanger), CAD-Duct, SprinkCAD, Revit MEP, Bentley Building Mechanical Systems, Graphisoft MEP Modeler.

---

## 7.7 ADOPTING BIM IN A FABRICATION OPERATION

A robust management strategy for the adoption of BIM must concern aspects beyond software, hardware, and the training of engineering staff, because of its range of impact on workflows and people.

BIM systems are a sophisticated technology that impacts every aspect of a fabrication subcontractor’s operations, from marketing and estimating through engineering, procurement of raw materials, fabrication, shipping to installation onsite, and maintenance. BIM does not simply automate existing operations that were previously performed manually or using less sophisticated software, it enables different workflow patterns and production processes.

BIM systems directly improve engineering and drafting productivity. Unless a company experiences sustained growth in sales volume through the adoption period, the number of people needed for these activities will be reduced. Downsizing may be threatening to employees whose energy and enthusiasm is critical for changing work procedures. A thorough plan should account for this

impact by considering and making provisions for all staff, both those selected for training and those for whom other tasks may be found. It should aim to secure involvement and commitment at an early stage.

### 7.7.1 Setting Appropriate Goals

The following guideline questions may help in setting goals for an effective adoption plan and for identifying the actors inside and outside the company who should be party to the plan. They apply equally to fabrication companies with in-house detailing capabilities and to companies that specialize in providing engineering detailing services.

- How can clients (building owners, architects, engineering consultants, and general contractors) benefit from fabricators' enhanced proficiency using BIM platforms? What new services can be offered that presently are not? What services can be made more productive, and how can lead times be shortened?
- To what degree can building model data be imported from upstream sources, such as from architects' or other designers' BIM models?
- How early in the process will models be compiled, and what are the appropriate levels of detail for models? Some fabricators are called upon to propose general design solutions at the tendering stage, where a low level of detail model can be an excellent tool for communicating a company's unique approach. Others are restricted to tendering on the designers' solution only, so that modeling begins with detailing only once a contract has been won.
- If a model has been prepared for tendering, how much of the information compiled is useful for the engineering and detailing phase that follows if the project is won?
- How and by whom will the company's standard engineering details and drawing templates be embedded in custom library components in the software? Will libraries be compiled at the time of adoption or incrementally as-needed for the first projects modeled?
- Can BIM offer alternative modes of communicating information within the company? This requires open discussion with different departments to ascertain real needs. Asking a production department head, "How do you want your shop drawings to look?" may miss the point in a BIM adoption, where alternative forms of presenting the information may be possible. Viewing, manipulating, and querying models on screen is a viable addition to traditional drawings. People need to be informed of the new possibilities.

- How will information be communicated to designers and consultants in the submittal process? BIM-capable architects and engineering consultants are likely to prefer to receive the model rather than drawings. How will review comments be communicated back to the company?
- To what degree will building models be used to generate or display management information? What is needed (software, hardware, programming) to integrate BIM systems with existing management information systems, or will new management systems be adopted in parallel? Most BIM software platforms provide not only fully functional authoring versions but also limited functionality viewing or reporting versions at lower prices than the full package. Such versions are likely to be adequate for production or logistics departments and personnel.
- What is the appropriate pace of change? This will depend on freeing-up the time of those individuals committed to the company's BIM adoption activities.
- How and to what degree will the existing CAD software be phased out? How much buffer capacity should be maintained during the adoption process? Are there any clients or suppliers who will not move to BIM and may therefore require that a limited CAD capacity be maintained?
- What are the needs and capabilities of any suppliers to whom engineering work is outsourced? Will they be expected to adapt? Will the company provide them some support in making the transition to BIM, or will they be replaced with BIM-savvy engineering service providers?

### 7.7.2 Adoption Activities

Once software and hardware configurations have been selected, the first step will be to prepare a thorough adoption plan, starting with definitions of the goals to be achieved and selection of the right staff to lead the adoption, both as managers and as first learners. Ideally, the adoption plan will be developed together with or by the selected leaders in close consultation with key people from the production and logistics departments companywide. The plan should detail timing and personnel commitments for all of the following activities:

- **Training engineering staff to use the software.** A word of caution: 3D object modeling is sufficiently dissimilar in concept from CAD drawing that some experienced CAD operators find the need to “unlearn” CAD behavior a serious barrier to effective use of BIM software. As with most sophisticated software, proficiency is built with practice over time; staff should not be trained until the organization can ensure that they can



devote time to continued use of the software in the period immediately following the training.

- ***Preparation of custom component libraries, standard connections, design rules, and so forth.*** For most systems and companies, this is a major task, but on the other hand it is a key determinant of the level of productivity that can be achieved. Different strategies can be considered. Custom components can be defined and stored incrementally as needed on the first projects performed; a large proportion of the libraries can be built ahead of time; or a mixed approach is possible. Larger companies may elect to dedicate a specially trained staff member to compile and maintain part libraries, because parametric modeling libraries are considerably more complex and sophisticated than those used with 2D CAD.
- ***Customization of the software to provide drawing and report templates suitable for the company's needs.***
- Immediately after training, the “first learners” can be tasked with ***“ghosting” a project.*** This involves attempting to model a project that is being produced in parallel using the standard CAD software. Ghosting provides an opportunity to explore the breadth of a real project, while not bearing responsibility to produce results according to production schedules. It also reveals the limitations of training and the degree of customization that will have been achieved.
- ***Seminars and/or workshops for those impacted but who are not direct users***—other departments within the company, raw material and processed product suppliers, providers of outsourced services, and clients—to inform them of the capabilities, enlist their support, and solicit ideas for improved information flows that may become possible. In one such seminar at a precast concrete company, the manager of the rebar cage assembly shop was asked to comment on various options for shop drawing dimensioning formats. Instead, he responded by asking if he could have a computer for 3D viewing of rebar cages color-coded by bar diameters, which he felt would enable his team to understand the cages they were to tie in a fraction of the time they currently needed to interpret 2D drawing sets.

### 7.7.3 Planning the Pace of Change

The introduction of new BIM workstations should be phased. The personnel undergoing training are likely to remain unproductive during their training and less productive than with CAD platforms during the early period, as they progress along a learning curve. The first people trained are also likely to be

unproductive for a longer period than most others, because they will have to customize the software to suit company-specific products and production practices. In other words, there is likely to be a need for *additional* personnel at the early stages of adoption, followed by a fairly sharp drop. This can be seen in the total number of personnel needed, as shown in the last row of each adoption plan in Table 7–4.

Table 7–4 shows a feasible plan for a phased replacement of a company’s existing 18 CAD workstations with 13 BIM workstations. It lists the numbers of CAD and BIM workstations planned for operation in each of the first four periods following the introduction of BIM software. It is based on estimates for two unknowns: the degree of expected productivity gain and anticipated rate of growth in business volume, if any. The rate of growth in volume can be expressed conveniently in terms of an equivalent number of CAD workstations needed to cope with the volume (the table shows two options, ignoring and considering growth in work volume). The rate of productivity gain used to prepare this table is 40 percent and is based on the number of hours required to produce the same output using BIM as would be produced using CAD. In terms of drawing production, that translates to 60 percent of the hours currently spent using CAD. This is a conservative estimate based on available measures from research, as detailed in Section 7.3.4.

**Table 7–4** Staged Adoption of BIM Workstations for a Fabricator’s Engineering Department

Adoption periods	Start	P1	P2	P3	P4
<b>Plan ignoring growth in work volume</b>					
Equivalent CAD workstations required	18	18	18	18	18
CAD workstations operating	18	18	13	3	
CAD workstations saved			5	15	18
BIM workstations added		3	6	2	
BIM workstations operating		3	9	11	11
Total workstations	18	21	22	14	11
<b>Plan considering growth in work volume</b>					
Equivalent CAD workstations required	18	18	19	20	21
CAD workstations operating	18	18	14	5	
CAD workstations saved			5	15	21
BIM workstations added		3	6	3	1
BIM workstations operating		3	9	12	13
Total workstations	18	21	23	17	13

Table 7–4 also demonstrates how downtime for training and reduced productivity at the start of the learning curve can be accounted for. A simplifying assumption in this regard is that the BIM workstations introduced in each period will only become fully productive in the period that follows. Thus, there is no reduction in CAD workstations in the first adoption period, despite the addition of three BIM workstations. In the second period, the reduction in CAD workstations is five and is equal to the number of BIM workstations that become productive (three, the number added in the preceding period) divided by the productivity ratio ( $3 \div 60\% = 5$ ).

The increase in personnel needed during the first adoption period may be ameliorated by outsourcing or by overtime, but it is likely to be the main cost item in a BIM adoption cash flow plan and usually significantly more costly than the software investment, hardware, or direct training costs. Companies may decide to stagger the adoption gradually to reduce its impact; indeed, planning period durations may be reduced over time (integrating new operators is likely to be smoother once more colleagues have made the conversion and as the BIM software becomes more deeply integrated in day-to-day procedures). In any event, from a management perspective, it is important to ensure that the resources needed for the period of change will be recognized and made available.

#### 7.7.4 Human Resource Considerations

In the longer term, the adoption of BIM in a fabricator's organization is likely to have far-reaching effects in terms of business processes and personnel. Achieving the full benefits of BIM requires that estimators, who are commonly among the most experienced engineers in a fabrication organization, be the first to compile a model for any new project, because it involves making decisions about conceptual design and production methods. This is not a task that can be delegated to a draftsman. When projects move to the detailed design and production stages, it will again be the engineers who are capable of applying the correct analyses to models and, at least, the engineering technicians who will determine the details. For trades such as electrical, HVAC and piping, communications, and so forth, detailing should be done in close collaboration with a general contractor and other trades to ensure constructability and correct sequencing of work, which again requires extensive knowledge and understanding of the domain.

As observed in Chapter 5 (BIM for the design professions), here too the skill set required of BIM operators is likely to result in a decline of the traditional role of drafting. Companies should be sensitive to this in their adoption plan, not only for the sake of the people involved but because BIM adoption may be stifled if the wrong people are expected to pursue it.

## 7.8 CONCLUSIONS

In purely economic terms, subcontractors that fabricate engineered-to-order components for buildings may have more to gain from BIM than any other participant in the building construction process. BIM directly supports their core business, enabling them to achieve efficiencies that fabricators in other sectors, such as the automotive industry, have achieved through the application of computer-aided modeling for manufacturing.

There are numerous potential benefits for fabricators. These include: enhanced marketing and tendering; leveraging the ability to rapidly produce both visualizations and accurate cost estimates; reduced production cycle times, allowing fabrication to begin at the last responsible moment and accommodate late changes; reduced design coordination errors; lower engineering and detailing costs; increased use of automated manufacturing technologies; increased preassembly and prefabrication; various improvements to quality control and supply chain management resulting from the integration of BIM with ERP systems; and much improved availability of design and production information for lifecycle maintenance.

While almost all fabricators and subcontractors can benefit from better coordination between their work packages and those of their peers, each trade can benefit in more specific ways, depending on the nature of their work. In this chapter, BIM practices were described in detail for a small number of trades: structural steel, precast concrete, cast-in-place concrete, curtain wall fabrication, and MEP trades. This is not meant to imply that BIM cannot be used effectively for other trades; we encourage every trade to consider and develop its opportunities, whether through organized group action or persistent trial-and-error by individual companies.

## Chapter 7 Discussion Questions

---

1. List three examples of engineered-to-order (ETO) components of buildings. Why do fabricators of ETO components prepare shop drawings?
2. What is the difference between made-to-stock and made-to-order components? Provide examples of each in the construction context.
3. How can BIM reduce the cycle time for marketing, detailed design, fabrication, and erection of ETO components in

construction? Select one type of component and use its process to illustrate your answers.

4. Why are preassembled integrated system modules, such as those described in Section 7.3.6, very difficult to provide using traditional CAD systems? How does BIM resolve the problems?
5. What are the ways in which BIM can facilitate lean construction?
6. What are the features of BIM systems that enable “push of a button” changes to details of the kind shown in Section 7.6?
7. Imagine that you are assigned responsibility for the adoption of BIM in a company that fabricates and installs HVAC ducts in commercial and public buildings. The company employs six detailers who use 2D CAD. Discuss your key considerations for adoption and outline a coherent adoption plan, citing major goals and milestones.
8. What are the features of building models, and what are the process benefits they bring, as opposed to 2D drawing practices, that make global procurement of ETO components possible and economical?



# The Future: Building with BIM

---

## 8.0 EXECUTIVE SUMMARY

BIM is not a thing or a type of software but a human activity that ultimately involves broad process changes in construction.

A wide variety of owners demand BIM use. Many large owners have developed contract terms and detailed guides for their design and construction service providers. New skills and roles are developing. Almost universally positive return on investment values have been reported by both design firms and construction contractors, with those actively measuring return on investment reporting that it exceeded their initial estimates. A survey conducted in early 2007 found that 28 percent of the U.S. AEC industry was using BIM tools; that number had grown to 49 percent by 2009. In 2007, only 14 percent of users surveyed considered themselves to be expert or advanced. By 2009, 42 percent did.<sup>1</sup> In the period from 2007 to 2010, contractors were the fastest adopters of BIM.

---

<sup>1</sup>These figures regarding BIM adoption are difficult to interpret in detail because of different questions being asked over time and lack of precision in interpreting such terms as “expert users.” However, the general trend of BIM use is quite clear.

BIM standard efforts—such as the National BIM Standards in the United States—are gathering steam; and the public is increasingly demanding greener buildings. BIM tools are becoming common in construction site offices. The lack of appropriately trained professional staff, rather than the technology itself, is still the current bottleneck for most companies. The greatest demand is for people who have experience both in modeling and in construction. Although pioneering universities and colleges are replacing their drafting classes with courses that educate architects and engineers in BIM, students who are BIM savvy may not be experienced in construction practice.

The technology trends include the development of automated checking for code conformance and constructability using building information models. Some vendors have expanded the scope of their BIM tools, while others offer more discipline-specific functionality, such as construction management functions. It is becoming more common for building product manufacturers to provide 3D catalogs; and BIM is helping to make globalization of fabrication for increasingly complex building subassemblies economically viable.

But BIM is a work in progress. As it develops and its use becomes more widespread, the extent of its impact on the way in which buildings are built will become more apparent. In this chapter, we first extrapolate from these trends to the short-term future. The next five years are likely to see much broader adoption of basic BIM tools. BIM will contribute to a higher degree of prefabrication, greater flexibility and variety in building methods and types, fewer documents, far fewer errors, less waste, and higher productivity. Building projects will perform better, thanks to better analyses and exploration of more alternatives, fewer claims, and fewer budget and schedule overruns. These are all improvements on existing construction processes.

Numerous societal, technical, and economic drivers will determine the development of BIM in the mid-term future (10 years). The latter part of this chapter identifies the drivers and obstacles in the timeframe leading up to 2020. We reflect on the likely impacts of the drivers on BIM technology, on the design professions, on the nature of construction contracts and the synergy between BIM and lean construction, on education and employment, and on statutory and regulatory processes.

The big picture is that BIM facilitates early integration of project design and construction teams, making closer collaboration possible. This will help make the overall construction delivery process faster, less costly, more reliable, and less prone to errors and risk. This is an exciting time to be an architect, an engineer, or any other AEC industry professional.



---

## 8.1 INTRODUCTION

BIM is changing the way buildings look, the way they function, and the ways in which they are built. Throughout this book, we have intentionally and consistently used the term BIM to describe an activity (*building information modeling*), rather than an object (as in *building information model*). This reflects our belief that BIM is not a thing or a type of software but a human activity that ultimately involves broad process changes in construction. In this chapter, we aim to provide two perspectives on the future of building using BIM: *where BIM is taking the AEC industry*, and *where the AEC industry is taking BIM*.

We begin with a short introduction describing the conception and maturation of BIM until the present (2010). We then provide our perspectives on what the future holds. The forecast is divided into two timeframes: a fairly confident forecast of the near future that looks ahead to the next five years (until 2015) and a more speculative long-term forecast looking ahead to the year 2020. The near-term forecast reflects current market trends—many of which are discussed in earlier chapters of this book—and then reviews current research. The long-term forecast relies on analyses of likely drivers and a fair amount of intuition. Beyond 2020, potential advances in hardware and software technologies as well as business practices, make it impossible to predict anything reliably, and so we refrain from speculation.

After 2020, construction industry analysts will reflect, with the benefit of hindsight, on the process changes that will have occurred by 2020. They will likely find it difficult to distinguish definitively between such influences as BIM, lean construction, and performance-driven design. In the absence of each other, these techniques could, theoretically, flourish on their own. Their impacts, however, are complementary in important ways, and they are being adopted simultaneously. Practical examples of their synergies are apparent in some of the case studies in the following chapter (such as Sutter Medical Center and the Crusell Bridge project). Researchers have cataloged some 55 positive interactions between BIM and lean construction (Sacks et al. 2010). We address some of these synergies in Sections 8.2 and 8.3.

---

## 8.2 THE DEVELOPMENT OF BIM UP TO 2010

BIM technology crossed the boundary between research concept and viable commercial tool in the first years of the past decade, and it is well on the way to becoming as indispensable to building design and construction as the

proverbial tee square or hammer and nail. The transition to BIM, however, is not a natural progression from computer-aided drafting (CAD). It involves a paradigm shift from drawing to modeling. Modeling provides different abstractions and model development processes, leading to new ways of designing. These are still being sorted out. BIM also facilitates—and is facilitated by—a concurrent shift from traditional competitive project delivery models to more collaborative practices in design and construction.

The concept of computer modeling for buildings was first proposed when the earliest software products for building design were being developed (Bijl and Shawcross 1975; Eastman 1975; Yaski 1981). Progress toward BIM was restricted first by the cost of computing power and later by the successful widespread adoption of CAD. But idealists in academia and the construction software industry persisted, and the research needed to make BIM practical continued to move forward. The foundations for object-oriented building product modeling were laid throughout the 1990s (Gielingh 1988; Kalay 1989; Eastman 1992). Parametric 3D modeling was developed both in research and by software companies for specific market sectors, such as structural steel. Current BIM tools are the fulfillment of a vision that has been predicted, by many, for at least three decades.

BIM technology will continue to develop rapidly. Just as the concepts of how BIM tools should work drove their technological development, a renewed vision of the future of building with BIM—emphasizing workflows and construction practices—is now needed. Readers who are considering the adoption of BIM tools for their practices and educators teaching future architects, civil engineers, contractors, building owners, and professionals, should all understand not only the current capabilities but also the future trends and their potential impacts on the building industry.

---

### 8.3 CURRENT TRENDS

Market and technology trends are good predictors of the near-term future in any field, and BIM is no exception. The trends observed reveal the potential direction and influence BIM will have in the construction industry. The following paragraphs outline the trends that influence our forecast. They are summarized in the sidebar “BIM Process and Technology Trends.”

**Sophisticated owners are demanding BIM and have developed contract terms and user guidelines to enable it.** The General Services Administration (GSA) of the U.S. federal government, representing a sophisticated owner,

demands the use of BIM models that are capable of supporting automated checking to determine whether the design meets program requirements. The *Veterans Administration BIM Guide* prescribes not only detailed technical requirements for BIM use, but also defines the process in terms of a BIM Management Plan that includes roles and responsibilities, model sharing, and collaboration procedures. Sutter Health, a California medical services provider with a multibillion dollar construction program, is actively encouraging the use of BIM by its providers as an integral part of its lean construction practices (see the Sutter Medical Center case study in Chapter 9). The Swire Properties One Island East case study (Chapter 9) is an example of a project in which an enlightened owner of a major skyscraper demanded the use of BIM. Owners like the Maryland General Hospital are reaping the benefits of detailed facility maintenance databases compiled during construction and commissioning by contractors using BIM (see the case study in Chapter 9). The building procurement departments of states, local government agencies, educational institutions, and companies are preparing and using BIM guidelines. All of these owners are motivated by the economic benefits they perceive to be inherent in building with BIM.

**Demand for people with new skills** (modelers with construction experience). The productivity gain for the documentation stage of precast and cast-in-place concrete structures has been measured in case studies and researched in numerous contexts, and has been found to be in the range of 30 to 40 percent. Although reliable numerical data is not yet available for architectural design, the trend observed is similar, and the implication is downsizing of drafting staff in building design practices of all kinds. On the other hand, many architects, engineers, and construction detailers are now needed for building information modeling roles. Architectural designers are sought that can effectively develop well-defined models that can support different assessments, for energy or cost/value. Engineers who can extract the analysis models needed to carry out structural or energy analyses and propose improvements to the building model design are especially in demand.

**New management roles have also developed.** Even in the depressed construction economy of the summer of 2010, a random Internet job search revealed hundreds of classified ads for employees with titles such as “AE BIM Manager,” “BIM Applications Support Engineer,” and “BIM Specialist.” Model managers fulfill two basic roles. At the company level, they provide software support services. At the project level, they work with project teams to update the building model, guarantee origin, orientation, naming and format consistency, and to coordinate the exchange of model components with internal design groups and external designers and engineers.

## BIM Process and Technology Trends

### Process Trends

- Owners are demanding BIM and changing contract terms to enable its use.
- New skills and roles are developing.
- A recent survey showed that the proportion of “very heavy” BIM users among all respondents grew from 34 percent in 2008 to 45 percent in 2009.
- Successful implementations in construction have led to corporatwide uptake by general contractors.
- The benefits of integrated practice are receiving wide review and being tested intensively in practice.
- Standards efforts are gathering steam.
- Green building is increasingly demanded by clients.
- BIM and 4D CAD tools have become common tools in large construction site offices.

### Technology Trends

- Automated checking for code conformance and constructability using building information models is becoming available.
- Major BIM platform vendors are adding functionality and integrating design assessment capabilities, providing even richer platforms for use.
- Vendors are increasingly expanding their scope and providing discipline-specific BIM tools.
- Building product manufacturers are beginning to provide parametric 3D catalogs.
- BIM tools with construction management functions are increasingly available.
- BIM is encouraging prefabrication for increasingly complex building subassemblies, which can be procured globally.

**Adoption among architects, engineers, and contractors has moved well beyond the “early adopters” stage.** By 2009, more than 50 percent of each of these groups reported using BIM at moderate levels or higher (Young et al. 2009). In 2007 only 34 percent of architects claimed they used 3D/BIM tools for “intelligent modeling” (i.e., not simply for the generation of 2D drawings and visualizations) (Gonchar 2007). In 2000, the use of intelligent modeling was rare.

**Successful implementations in construction have led contractors to reengineer their processes, beginning to take corporatwide advantage of the benefits they have identified.** Pilot projects that made early intensive use of what were still imperfect BIM tools—and showed dramatic success—have indicated the nature of the technology’s impact on construction. Among the case studies in Chapter 9, the Sutter Medical Center project showed how BIM is essential in enabling the close collaboration needed in integrated project delivery (IPD) projects, including lean pull flow control for detailing of MEP systems, resulting in a high degree of offsite preassembly; and the Crusell Bridge structure showed how prefabrication can be almost entirely error-free. Construction contractors have established in-house training programs—such as Turner Construction’s eight-week Virtual Design & Construction (VDC) training program, called “Turner BIM University”—to educate college graduate new hires in the company’s approach to using BIM in its projects (Krause 2010).

**The benefits of integrated practice are receiving wide review and extensive experience using IPD on specific projects has been accumulated.** Leading AEC firms increasingly recognize that future building processes will require integrated practice of the whole construction team and will be facilitated by BIM. All members of the building team, not only the engineering consultants but contractors and fabricators, are recognized to have valuable input for design. This is leading to new forms of partnerships, with more design-build projects, more construction firms incorporating their own design offices, and more innovative and intensive teaming. The American Institute of Architects has published guidelines for Integrated Project Delivery (IPD) and numerous case studies of successful application have been reported (AIA 2007; Cohen 2010).

In the previous edition of this book, we predicted collaborative innovations in project delivery mechanisms in the medium term (2012 to 2020): “New forms of contracts will be explored, based on Limited Liability Corporations (LLCs) and the Australian form of relationship contracting.” In fact, this has developed more quickly than expected, with the Integrated Project Delivery approach developed in the United States (ConsensusDocs 300 series and AIA agreement forms). The balancing of risk and rewards is becoming a part of the equity relationship with clients, with contracts that explicitly state the distribution of benefits as well as penalties. A good example of such an effort is the Sutter Health Integrated Form of Agreement (IFOA), with its gain and pain sharing provisions, presented in the Sutter Medical Center case study in Chapter 9.

**Standards efforts are gathering steam.** In 2006, the American Institute of Steel Construction amended its code of standard practice to require that a 3D model, where it exists, be the representation of record for design information. In the United States, the National Institute for Building Sciences (NIBS) is

facilitating industry definition of a set of National BIM Standards, which aims to precisely specify data exchanges within specific construction workflows. Numerous industry interest groups are preparing “Model View Definitions” as part of this effort<sup>2</sup> and all major BIM tool vendors now support, to a lesser or greater degree, some form of IFC standard exchange. The new IFC 2x4 version has now been released. The COBie exchange standard (Construction Operations Building information exchange) for handover of equipment lists, product data sheets, warranties, and other as-built information is being adopted.

**Green building is increasingly demanded** by a public conscious of the threats of climate change. BIM helps building designers achieve environmentally sustainable construction, by providing tools for the analysis of energy needs and for accessing and specifying building products and materials with low environmental impact. BIM tools can also assist in the evaluation of projects for LEED compliance. In response to demand, vendors have embedded energy analysis tools within BIM platforms, although doubts regarding the accuracy of energy consumption analyses remain. The U.S. federal Department of Energy is funding new research to improve the tools for building energy simulation.

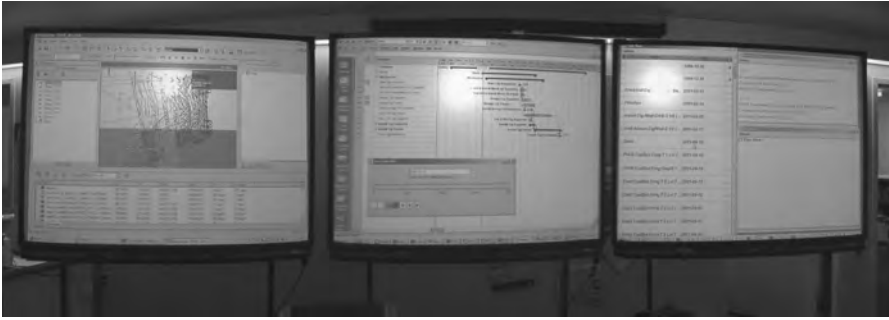
**BIM-integrated 4D CAD tools are becoming more common in construction offices.** Over the past decade, 4D tools have gradually moved from the research lab (McKinney et al. 1996; McKinney and Fischer 1998) to the construction office and site (Haymaker and Fischer 2001; Schwegler et al. 2000; Koo and Fischer 2000). BIM use is evident onsite in most of the case studies in Chapter 9. Today, all major BIM tool vendors provide 4D functionality, and several smaller companies also sell 4D tools.

With increasing amounts of information available electronically and as building information models incorporate more process annotations, information visualization is becoming central to the overall work process. Multidisplay environments or **interaction information workspaces** (Liston et al. 2000; Liston et al. 2001) are found in many offices and sites. New environments, such as the iRoom shown in Figure 8–1, enable project teams to interact with the building information model and the entire information space. Team members can simultaneously view the model, the schedule, specifications, tasks, and relationships between these views.

**Automated model verification tools for checking program compliance and constructability using building information models have become available.** In Singapore, part of the design checks of building code compliance required for building licenses are already automated. Innovative companies, such as Solibri

---

<sup>2</sup>Some MVDs are coordinated on the “IFC Solutions Factory” Web site (see [www.blis-project.org/IAI-MVD/](http://www.blis-project.org/IAI-MVD/)).

**FIGURE 8-1**

Sample of a multidisplay workspace with related views of the project model: (left screen) a 4D view of the project; (middle screen) the schedule; and (right screen) component property list and specification information.

Image provided courtesy of CIFE, Stanford University.

and EPM, have developed model-checking software (Jotne 2010; Solibri 2010) using IFC files and are intent on extending their capabilities. Coordination between complex building systems using superimposed 3D models is becoming common, and checks go beyond identification of physical clashes.

**BIM vendors are increasingly expanding their scope and providing specific tools to an expanding set of disciplines.** Major BIM vendors are adding discipline-specific interfaces, objects, design rules, and behaviors to the same base parametric modeling engine (witness “XXX Building/Architect,” “XXX Structure,” “XXX MEP,” etc.). These vendors have also extended the scope of their software capabilities by acquiring structural analysis applications. One such vendor has purchased a building systems coordination application; another has developed and incorporated a sophisticated contractor site management application. Energy analysis tools that were previously independent (Ecotect and Green Building Studio) have been acquired by Autodesk. Other vendors are also expanding the breadth of their platforms.

**Building product manufacturers are beginning to provide 3D catalogs.** Products as diverse as JVI mechanical rebar splices, Andersen windows, and many others can be downloaded as 3D objects and inserted parametrically into models from several online sites. Content libraries such as Reed Construction Data’s SmartBIM Library, Autodesk Seek, and other similar tools provide large repositories of building product content for BIM. Content is increasingly accessible through search engines. Product libraries are primarily developed for the most common BIM tools, such as RVT file type families, but all are supported in varying degrees.

**Construction management functions are being integrated into BIM tools.** The extension of 4D CAD to include cost—what is called *5D CAD*—and further extension to incorporate additional management parameters to *nD CAD* are already being undertaken by various solution providers. These promise to offer better insight into how projects can be built feasibly and reliably. The concept of *virtual construction* is no longer familiar only to the research

community. It is increasingly being used and appreciated in practice, as indicated by the *Virtual Design and Construction Survey* (VDC) (CIFE 2007). Vico Office 2010 (VicoSoftware 2010) is an example of this trend; Innovaya (Innovaya 2010) is another.

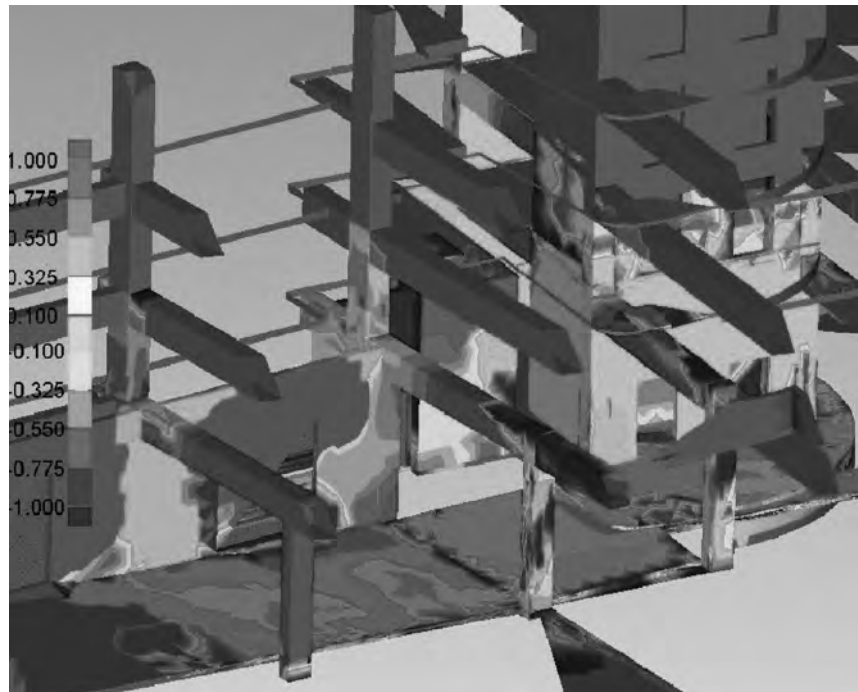
**BIM is helping to make the fabrication of increasingly complex building subassemblies economically and globally viable.** Large curtain wall system modules are already being fabricated in China, at costs and quality that are difficult to match (see the 100 11th Ave., New York City case study in Chapter 9 for an example). The need for transport time allowances means that lead times for design are short, and the modules must be fabricated right the first time. BIM produces reliable and error-free information and shortens lead times. It allows a larger portion of a project to be prefabricated offsite which reduces costs, increases quality, and simplifies the construction process. The Aviva Stadium in Chapter 9 is an excellent example of “design for fabrication.”

**Technology developments in peripheral hardware are enabling linking of the virtual BIM world to the physical construction world.** The continued development of laser scanning, radio-frequency ID (RFID) technology, and portable computers is enabling data transfer in both directions between BIM and construction site. Laser scanning can produce *point cloud surveys* of existing physical geometry that can be used for designing renovation or refit work. When matched to a 3D model, as shown in Figure 8–2, point cloud data can be

**FIGURE 8–2**

Laser scanning point cloud data can be mapped onto BIM objects to show deviations of the as-built geometry from the designed geometry. The colors represent the degree of deviation from the planned (gray) surfaces, according to the scale at the left of the figure. (See color insert for full color figure.)

Image courtesy of Elsevier (Akinci et al. 2006).





used directly to highlight deviations of the as-built geometry from the designed geometry (Akinci et al. 2006). The highly accurate measurements of physical reality can also be used for monitoring construction progress. The Crusell Bridge case study and the Portland Marriott Hotel (Chapter 9) illustrate how scanning enabled accurate placing of assemblies in relation to the formwork for cast-in-place concrete.

RFID tagging was used to monitor over 3,000 precast concrete components across their entire supply chain in the Meadowlands Stadium project in New Jersey (Sawyer 2008). Specialized software for collecting and synchronizing data collected in the field using portable computers with building models has become commonplace, and its use is fueled by the explosive growth in adoption of portable computers such as the Apple iPad (Vela Systems 2010). The process and technology trends outlined above were formative in our attempt to look ahead at the future of building with BIM, in this chapter's following sections. BIM, however, is not developing in a vacuum. It is a computer-enabled paradigm change, and so its future will also be influenced by developments in Internet culture and by other similar and less predictable drivers.

---

## 8.4 VISION 2015

Recent years have witnessed the realization of many of the ideas of BIM visionaries, and the next five years will see increasing numbers of successful implementations, changes in the building industry, and new trial uses and extensions of what can be achieved with BIM, beyond its use today. This period will see the transition of BIM to accepted mainstream practice; and the transition will impact all building professionals and participants. But the greatest impact will be on the individual practitioner, who will need to learn to work, design, engineer, build, or manage with BIM.

### 8.4.1 Impact on Owners: Better Options, Better Reliability

Owners will experience changes in the quality and nature of services available and an overall increased reliability of the project budget, program compliance, and delivery schedule. Many owners are already experiencing this. Advanced owners are leading their project teams to adapt and expand their BIM-related services. Chapter 4 and several of the case studies describe owners who were introduced to or who demanded new processes and deliverables. Within the next five years, owners can expect the changes in the design professions—discussed in the previous section—to translate into more offerings by service

providers to deliver a building information model and to perform services related to analyzing, viewing, and managing the model's development.

In the early project phases, owners can expect to encounter more 3D visualizations and conceptual building information models with programmatic analysis (see Chapter 5 for a discussion of these tools). Building models are far more communicative and informative to lay people than technical drawings. With the increasing availability of 3D-based Internet technologies, like earth viewers and virtual communities, owners will have more options to view project models and use them for marketing, sales, and evaluation of designs in the site context. Building models are far more flexible, immediate, and informative than computer-renderings of buildings produced using CAD technologies. They also enable owners and designers to generate and compare more design options early in the project, when decisions have the most impact on the project and lifecycle costs.

These technical developments will have different impacts for different owners, depending on their business incentives. Owners who build to sell will find that they can demand and achieve much shorter design durations for conceptual design and construction documentation. On the other hand, for owners who have an economic interest in the lifecycle costs and energy efficiency of their buildings, the conceptual design stage will provide the opportunity for an in-depth study of the behavior of each alternative building design. Savvy owners—with the perception that conceptual-level models can be developed and evaluated rapidly—are likely to demand higher design quality. In an effort to optimize building design, they will demand thorough exploration of more alternatives, in terms of construction cost, sustainability, energy consumption, lighting, acoustics, maintenance, and operations and other criteria.

During this time period, more advanced analysis and simulation tools will emerge as options for specific types of facilities, such as healthcare, public access areas, stadiums, transit facilities, civic centers, and educational centers. Figure 8–3 shows an example of a tool that allows healthcare owners and their designers to compare different configurations of hospital rooms with different equipment. Since the actual occupants and users are central to assessing and evaluating any design, tools that work integrally with a BIM system to provide intelligent configuration capabilities will become more widespread.

Similarly, sophisticated construction clients will drive the development of automated design review software for different building types. These will assess a given building design at different stages of development and according to different preset guidelines. For example, the GSA is already extending its program area checking tool to other aspects of design and other building

**FIGURE 8-3**

Example of a component-based simulation of an operating room, allowing the owners and designers to compare different equipment. The equipment components include parameters and behaviors, ensuring that proper clearances and distances are maintained.

Image provided courtesy of View22 and GE Healthcare.

types. One program allows for circulation assessments of various layout options during conceptual design. It focuses on courthouses, which have major circulation and security requirements. An early example of this type of testing is shown in Figure 8-4. Other public or private organizations can be expected to develop similar protocols for other building types, such as hospitals and schools.

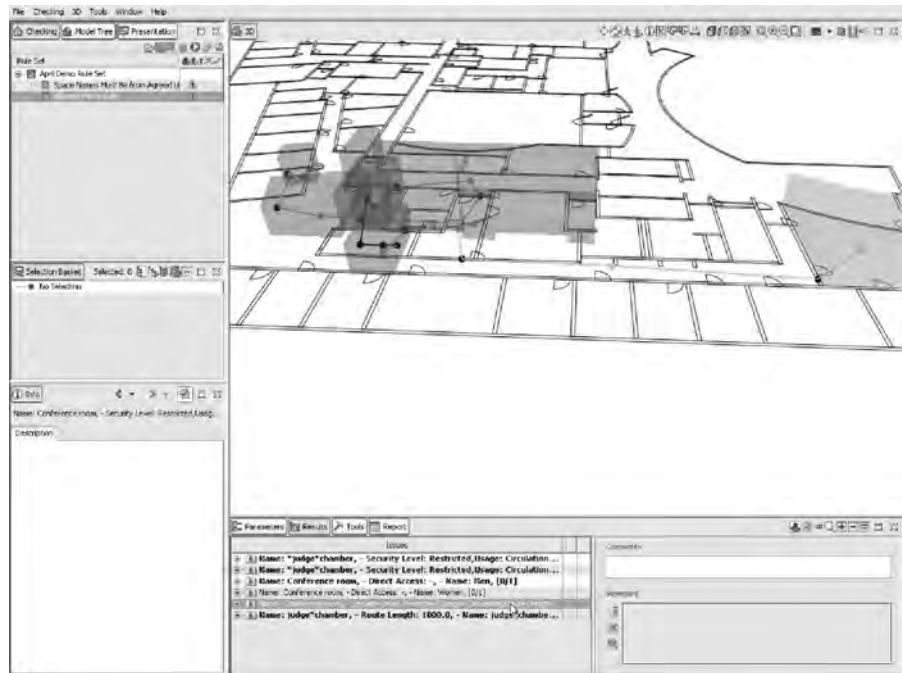
For first-time (and often one-time) construction clients, different and less desirable possibilities may occur. They may not be familiar with BIM and its potential uses and, as a result, may not adequately engage the design team in assessing the project's more subtle goals regarding function, cost, and time-to-delivery. If designers are not disciplined, they can develop fairly detailed designs rapidly and create building models that appear convincing and appealing. If the vital stage of conceptual design is short-circuited, premature production level modeling can lead to a lot of rework later in the process. In the worst cases, inadequately designed buildings that do not meet the clients' needs may be built. Like any powerful technology, BIM too is open to abuse. Building clients unfamiliar with the capabilities that BIM technology offers are advised to educate themselves and select knowledgeable design consultants in order to obtain professional design services that exploit the technological capabilities of BIM to achieve the desired objectives of the project.

Smart owners, on the other hand, will demand a faster and more reliable building process from their design and construction teams. The use of

**FIGURE 8-4**

A courthouse circulation path that fails to provide secure access between a trial jury room and a restroom. The system checks the security zones of all possible paths, which may span multiple floors.

(GT-COA 2007; Solibri 2010).



design-bid-build for private construction will continue to decline, as owners realize that an integrated team is the best way to obtain value from BIM technology. They will start measuring BIM teams by the number of requests for information (RFIs) and delays on prior projects (get it right the first time). The number of claims should go down as the design and construction process becomes more efficient. Lawyers and expert witnesses will become a smaller part of the owner's life (and fears). Time and cost contingencies will shrink. Clients that build frequently will look for teams of design and construction professionals that have BIM experience and know how to leverage these tools with lean processes.

Similarly, the improvements BIM brings to the construction process itself will begin to manifest in lower construction costs and better performance. When projects that make intensive use of BIM in concert with lean construction methods are consistently delivered within or under budget and schedule, such as the Camino Medical Center (featured as a case study in the first edition of this book) and the Sutter Medical Center in Castro Valley (see Chapter 9) among others, owners will come to expect, and so demand, better performance across the construction industry.

As the use of 4D and BIM-coordination by contractors becomes more commonplace, owners will increasingly appreciate the power of these tools to

improve budget and schedule reliability as well as overall project quality. They will begin to require status reports, schedules, and as-built viewable models in BIM formats. More owners will seek out model managers or require that their construction manager perform this task and facilitate the model management network, increasingly on BIM Web servers. Thus, owners will increasingly need to address intellectual property issues, if individual members of collaborative teams contribute proprietary information (Thomson and Miner 2006).

Post-construction, owners will consider whether or not to use the model for facility management, as discussed in Chapter 4. The trend set by efficient delivery of as-built information directly from the commissioning process in the field into BIM datasets, as exemplified in the Maryland General Hospital case study (see Chapter 9), will encourage owners to adopt BIM-based facility management systems. If they choose to do so, they will need to learn how to update and maintain them. During this time, we can expect increased use and maturation of BIM-based facility management products. We will see the first cases of building information models integrated with building monitoring systems for comparing and analyzing predicted and observable building performance data, which will provide owners and operators with better tools for managing their building operations.

#### **8.4.2 Impact on the Design Professions: Shifting Services and Roles**

Designers will experience productivity gains at the construction stage and deliver higher quality design services. In the next five years, architects and other designers will continue to adopt BIM, and by the end of the period, 80 to 90 percent of firms will have worked on a project making full use of BIM, compared to the 25 percent that used it in 2007 (Gonchar 2007) and the 49 percent using it today (Young et al. 2009). The three main drivers for broad adoption will be: (1) client demand for enhanced quality of service; (2) productivity gain in preparing documentation; and (3) contractor demand to support virtual construction. The competitive advantage BIM provides will motivate individual firms to adopt BIM, not only for the sake of internal improvement but to gain a competitive advantage in the marketplace.

The most significant shift for design firms will be in the quality and nature of their services. Currently, designers mostly rely on experience and rule-of-thumb judgments regarding cost, functional performance, and energy and environmental impacts of their designs. Most of their time and effort is spent producing project documents and on meeting explicit owner requirements. Some of the case studies and sections in this book note how early adopters of BIM are beginning to move toward performance-based design, by using

tools to better inform their design decisions. Design firms (with a push from clients) will begin to broaden their scope of services to include detailed energy and environmental analyses, operations analyses within facilities (such as for healthcare), value engineering based on BIM-driven cost estimates throughout the design process, and evaluation of designs for conformance to LEED certification requirements.

And these are just a few of the possibilities. Initially, these services will be market differentiators. Later, they will become more widely adopted by much of the field. As these firms develop their new technical environments and expertise with BIM, the late adopters or non-BIM design firms will find it increasingly difficult to compete.

Architecture and engineering firms already face a workplace with changing roles and activities. Junior architects are expected to demonstrate proficiency with BIM as a condition of employment, in the same way that CADD proficiency was required since the 1990s. Some downsizing will occur among staff members dedicated to document-producing activities. New roles are emerging with titles such as the *building modeler* or *model manager*, requiring design and technical know-how. A profound change that the IPD trend introduced in the previous section will bring to many designers' working environments is the move to colocation of designers from all disciplines in a single office space dedicated to a major project. Working in a common office, with a "big room" for frequent coordination meetings centered on an integrated building model representation, represents a significantly different way of working when compared with the way designers function in their own office.

As detailing and documentation production phases become increasingly automated in various areas of engineering, cycle times for processing will be significantly reduced. These trends were already witnessed in the Crusell Bridge and the 100 11th Avenue New York case studies (see Chapter 9). Little's Law (Hopp and Spearman 1996), which relates cycle times and levels of work-in-progress to throughput, explains that for any given workload, reducing cycle times means that the level of work in progress is reduced. The implication is that firms should be able to reduce the number of projects they have in active design at any given time in their practices. Thus, some of the waste inherent in moving employees' attention from one project to another at frequent intervals may be reduced.

BIM tools and processes will facilitate the trend first enabled by the Internet to divest and outsource services, leading to further empowerment of small firms with a highly technical and BIM-skilled staff. Increased opportunities will exist to provide freelance technical or very specialized design services in response to the ever-growing complexity of building systems and materials. Three of the case studies in Chapter 9 benefited from outside specialist advisors contributing to

the use of BIM (the Sutter Medical Center, 100 11th Avenue New York City, and the One Island East Hong Kong project). Consortia of specialist design firms are able to collaborate around a common building model, often achieving outstanding team results in shorter times than was ever possible with drawings. This makes it both efficient and practical for such firms to provide new design and performance analyses and/or production advice under the leadership of the primary design firm, which may be a large or a small innovative firm with high design and coordination skills. In some ways, we may see an acceleration of the trend described in Section 5.3 and a similar evolution of design services that we saw over the last 40 years in contracting services. Interoperability will positively influence and expand these trends. The contracting design firm will do a reduced amount of work but will coordinate and integrate the work of multiple specialist advisors. These trends are evident today and will grow incrementally to respond to the increasing complexity of design services.

Although much will change, many aspects of building design will stay rooted in current practice. In the short term, the majority of clients, local regulatory authorities, and contractors will continue to demand drawings and paper documentation (or equivalent 2D electronic documents) for projects. Many nonleading design practices will only use BIM to generate consistent drawings for team communication and handoff to contractors. Only a minority of firms will have distinguished themselves by integrating building performance capabilities with standard general design functions.

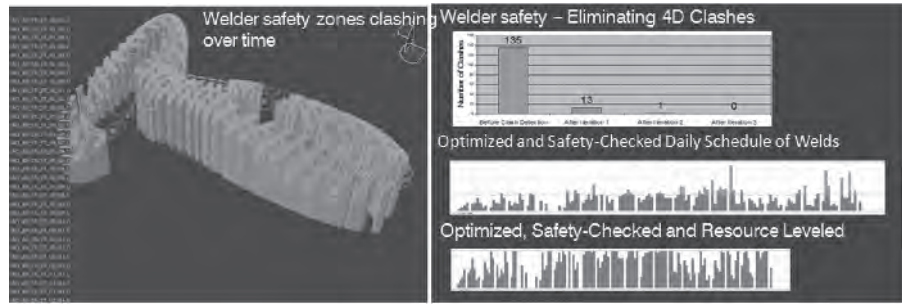
### **8.4.3 Impact on Construction Companies: BIM at the Construction Site**

Construction companies, for competitive advantage, will seek to develop BIM capabilities both in the field and in the office. They will use BIM for 4D CAD and for collaboration, clash detection, client reviews, production management, and procurement. In many ways, they will be in a better position than most other participants in the construction supply chain for leveraging the short-term economic benefits of ubiquitous and accurate information.

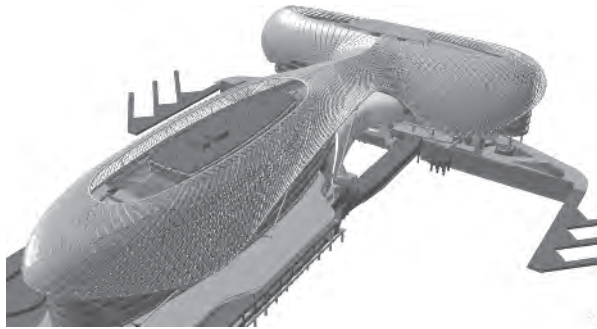
Chapters 6 and 7 explained how BIM can contribute to reducing construction budgets and schedules, as a result of better quality designs (i.e., fewer errors) and by enabling greater degrees of prefabrication. A positive effect of the ability to develop design details fairly early in the process is that rework, which commonly results from unresolved details and inconsistent documentation, is mostly eliminated. These effects have already been reported in numerous cases, such as the Crusell Bridge and the 100 11th Avenue New York projects detailed in Chapter 9 and in pioneering projects like the Denver Art Museum Extension.

**FIGURE 8-5**

The Yas Island Formula One. Top image shows the physical spaces that model the weld crew's workspaces to find unsafe interferences. (See color insert for full color figure.) Bottom image shows the overall frame of the structure.



Architect: Asymptote Architecture. Images courtesy Gehry Technologies.



The richness and ready availability of information in a building model will enable novel applications for planning work onsite, including aspects other than cost and schedule. Construction safety is a key concern, and BIM can be used to plan work to account for safety issues. Evaluation of the risk level of production plans using information models and safety knowledge databases has already been demonstrated in research (Rozenfeld et al. 2009). In practice, the clash detection capabilities of Digital Project have even been used in an innovative way to detect clashes between the workspaces of welding crews in the Yas Island Formula One project in Abu Dhabi (Gerber et al. 2010), as shown in Figure 8-5.

Some mechanical parametric modeling software companies may develop products for different types of construction fabrication that are designed for and integrated with NC fabrication equipment. This will allow new custom-fabricated products to increasingly become part of construction, including molded plastic panels, façade panels, novel kinds of ductwork, and others.

The role of the *building modeler* will be an issue among contractors and fabricators, due to the mixed roles of senior staff and the complexity of some detailing systems. As third-party engineering service detailers for precast, reinforced concrete and other systems gain proficiency in BIM, they will become the de facto building modelers in the same way as in the steel fabrication business.



This period should see increasingly smoother transitions from design models to construction models. Software *wizards*—using parametric templates of work packages with embedded construction methods—will be applied, to rapidly compile a construction model from a design model. Ideas like the *recipes* in the Vico Office suite (Vico Software 2010) are an early indication of what can be expected. For example, a parametric template for a post-tensioned flat slab will lay out the formwork design and determine labor and equipment inputs, material quantities, and delivery schedules based on a generic slab object in a design model. A resulting construction model can be analyzed for cost, equipment, and logistic constraints and for schedule requirements; and the alternatives can be similarly compared. Thus, construction planning will be greatly enhanced. The parametric templates will also serve as a repository for corporate knowledge, in as far as they will embed an individual company's way of working into these software applications.

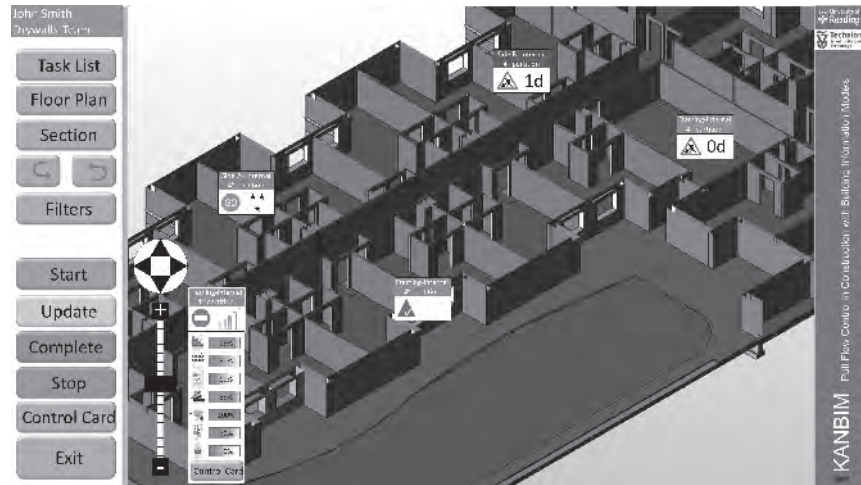
The trend of use of BIM and 4D CAD in construction site offices will deepen, and extend from site offices to the workspaces themselves. Building information models will serve as the core of entirely new production management information systems for construction onsite. Systems like the prototypical “KanBIM™” system, researched and developed by a consortium led by the Technion–Israel Institute of Technology (Sacks et al. 2010), provide crew leaders at the work face not only with product information, but with process information. Process information enables them to “see” the status of shared equipment, what other teams are doing, where materials are along the supply chain, what spaces are available for work, and so forth, all of which enables them to make intelligent choices about their own work progress. KanBIM™ embeds use of the Last Planner System™ lean construction work planning and control system, adding information visualization using large format, all-weather touch screens on the jobsite with building models at the core of the information acquisition and delivery system. Figure 8–6 shows a typical interface and use of such a tool onsite.

#### **8.4.4 Impact on Construction Contracting: Closer Collaborations among Designers and Contractors**

As we have noted in Chapter 6, BIM provides considerably more advantages in the context of design-build and integrated project delivery type procurement arrangements. As design and construction companies gain experience with BIM, recognition of the added-value that can be achieved will push them to move building procurement from design-bid-build to negotiated contracts, cost-plus, design-build, construction management at risk, and IPD arrangements.

**FIGURE 8-6**

Shows (top) an example of a KanBIM user interface, and (bottom) a large format touch screen for its use on a construction site (Sacks et al. 2010).



Some construction companies will expand their services in the areas of model development and management. Others may provide package services for full building delivery through a leveraged use of BIM technology.

Both the Internet and BIM tools will facilitate increasing degrees of globalization in construction, not only in the design and parts supply but in the fabrication of engineered-to-order components of increasing complexity. The fabrication of the steel and glass panels of the curtain wall system for the 100 11th Avenue, New York City case study project is an early example. The accuracy and reliability of production data prepared using BIM allowed building products and assemblies that would traditionally be procured locally to be made anywhere in the world. Curtain wall panels are one example. Large

modular prefabricated utility systems or complete bathroom units may be others. Competition in the construction fabrication area will spread globally.

As discussed in Chapter 7, BIM facilitates prefabrication and preassembly, making their engineering coordination essentially error-free, and thus more economical than previously possible. With the pressures for better, quicker, and less-expensive buildings, modular design and manufacture of larger and more complex custom building parts will become widespread. Modules are conceptually similar to prefab components, but larger, more complex and often not replicated. The manufacturing industry calls it mass-customization. Building will become more like manufacturing, with much of the work done by offsite vendors who create modules that are shipped to the jobsite and assembled into finished buildings.

#### **8.4.5 Impact on Construction Education: Integrated Education**

Leading schools of architecture and civil engineering have already begun teaching BIM to undergraduates in their first year, and that trend is likely to spread in parallel with the adoption of BIM in the design professions. One author's experience to date in teaching BIM is that students are able to grasp the concepts and become productive using BIM tools more quickly than they were with CAD tools (Sacks and Barak 2010).

The lack of trained personnel remains a significant barrier to BIM adoption, forcing many companies to retrain experienced CAD operators in the new tools. Because BIM requires different ways of thinking about how designs are developed and building construction is managed, retraining requires not only learning but the unlearning of old habits, which is difficult. New graduates, whose entire undergraduate experience was influenced by their familiarity with BIM and its use for the full range of student projects, are likely to have a profound influence on the way companies of all kinds deploy BIM. Inevitably, a good deal of innovation in work practices is to be expected.

#### **8.4.6 Impact on Statutory Authorities: Planting the Seeds of Online Access and Review**

One possible impact of the Internet is its ability to empower the public at large to participate in statutory processes, such as the approval or rejection of building plans. Posting building designs for public review, however, is still rare. One of the reasons may be that the accepted format of drawings is not accessible to the average citizen. If navigable 3D models of proposed buildings were placed within a realistic depiction of their context and posted online, a more democratic public review process would be feasible.

Visual inspection is already technically possible within the Google Earth® environment, but the idea can be extrapolated to envisage the merging of multiple information sources to create a virtual environment in which design and approval takes place using BIM. Geographical Information Systems (GIS) are commonplace in many municipal jurisdictions and utility services. The data includes topographical conditions, infrastructure facilities, existing structures, environmental and climate conditions, and statutory requirements. The challenges of interoperability for this kind of GIS information are not quite as complex as they are for exchanging intelligent building models; it may become possible and economically viable for jurisdictions to provide models in packages for individual project sites, which could be delivered to building designers for use directly within their BIM authoring tools.

Green or sustainable construction practices are likely to get a boost from BIM, because building information models can be analyzed for compliance with energy consumption standards, for their use of green construction materials, and for other factors included in certification schemes like LEED. The ability to automatically assess building models will make the enforcement of new regulations more practical. Such capabilities are already available through gbXML. Some building codes already require that energy analyses be performed on all buildings, to comply with standards for energy consumption. The use of performance-based standards, as opposed to prescriptive standards, is likely to increase. All of these trends will put great pressure on developing better metrics for addressing the accuracy of energy and sustainability models. The first energy calculation tools integrated within BIM tools are already available, which means that BIM will facilitate the push for sustainable buildings.

#### **8.4.7 Impact on Project Documentation: On-Demand Drawings**

The importance of drawings is expected to decline as BIM becomes ubiquitous on construction sites, but drawings are unlikely to disappear until digital display technologies are flexible and hardy enough for everyday use onsite (this is discussed in the medium-term forecast below). One function of drawings in today's construction industry is for documentation of business transactions in the form of appendices to construction contracts. Already, however, there are indications that building information models can better serve this purpose, partly because of their improved accessibility to nonprofessionals.

Because drawings can be produced on-demand from the model using customized formats, the development of better onsite documentation for crews and installers will lead to new capabilities. Isometric views with sequential

assembly views and bills of material will facilitate crew operations. An early example is presented in Figure 5–18.

A technical and legal hurdle that must be resolved is the notion of *signing* a digital model, or even its individual components. Another is the issue of whether access to models in the future, as applications develop and old versions are no longer supported, will remain reliable. Both of these issues have been resolved in other business fields, and the economic drivers are strong enough to ensure that they will be resolved for building models too. Solutions may take advantage of advanced encryption technologies, third-party archiving of original model files, neutral view-only formats, and other techniques. In practice, a growing number of project participants already choose to build according to models, rather than drawings. Legal practice will have to keep pace with commercial practice.

#### 8.4.8 Impact on BIM Tools: More Integration, More Specialization, More Information

Building information model generation tools still contain broad room for improvement and enhancement, in terms of the breadth of their coverage of the building construction domain. They can also expand on the types of parametric relationships and constraints they support. These tools will incorporate increasingly comprehensive families of building parts and products.

The ready availability of BIM platforms will encourage a new wave of plugins that will emerge over the next five years. Several areas of new product development are likely. One may be the emergence of better tools for architectural conceptual design, integrating aspects of DProfiler (Beck Technology 2010), Trelligence Affinity (Trelligence 2010), and Autodesk Ecotect (Ecotect 2010), as discussed in Chapter 5. Another likely area will be layout and fabrication tools for new materials and building surfaces. Yet others might include new support software for store layout, fixturing, interior office layout, and detailing by the many design-related trades that serve building owners or lessees and the like.

Increased **integration of analysis interfaces** within design modeling software is technically feasible and desirable. Competition between vendors of leading BIM platforms interested in providing comprehensive suites of software products is already evident, because the issue of interoperability remains insufficiently resolved. Vendors can build BIM software suites either by buying up analysis software providers or by forming alliances that enable an analysis preprocessor to run directly from their interfaces. The trend began with embedded structural analysis software, continued with energy analysis, and is likely to be pursued further with acoustic analyses, estimating, building code compliance, and planning compliance. The issues of developing a building model able

to support a range of heterogeneous applications will grow quickly to become a major issue. Strategies for overcoming these bottlenecks and for managing workflows, over the design lifecycle, will become a major area of focus.

Because of the large and growing size of BIM project files and the difficulties inherent in managing model exchanges, there will be a growing **demand for BIM servers** with the potential for managing projects at the *object* level, rather than at the file level. These issues are discussed in detail in Chapter 3 (Section 3.5), which also lists and details some early BIM servers that are already available. ArchiCAD was the first major BIM platform to offer object level capability, with its DELTA-server™ technology, which became available in 2010 (Graphisoft 2010). BIM servers may be offered by a variety of companies, including BIM platform software companies, existing project collaboration Web service providers, and new startups. They may be hosted and used within a single design firm or a single project basis, or provided as a cloud computing service. The technology for such exchanges already exists within those BIM systems that enable multiple users to access the model simultaneously, by locking individual objects; all that is needed is to port that capability to a larger and more functionally complete database environment. Given that transactions are primarily incremental updates of objects and their parameters (as opposed to complete model exchanges), the actual amount of data that needs to be transferred is fairly small, certainly much smaller than equivalent sets of CAD files. However, a word of caution: as discussed in Section 3.5, BIM servers will eventually need to maintain integrity among objects created by different platforms for different purposes. This capability is unlikely to develop and mature within the 2015 timeframe.

**Model viewer software** such as DWF viewers, Tekla's and Bentley's Web viewers, 3D PDF, and others are becoming important tools, due to their simplicity. They are likely to begin offering more extensive information than just graphics and basic object IDs and properties. A wide variety of applications—including quantity takeoffs, basic clash checking, and even procurement planning—can be used as information consumers only; they do not need to update information to BIM models. As such, they may be able to run directly from DWF-style files. These simplified file formats may be exploited by a variety of *output only* third-party plug-ins for use with Web interfaces.

New tools for locating and inserting building product and assembly models, called *building element models* (BEMs) (Arnold 2007), are under development. Two development issues are **semantic searching and compatibility of BEMs to multiple BIM platforms**. Today, we are already able to search the Web and find building products based on user-defined criteria, if one knows product names and/or standard material names. Semantic searching

will enable searches that accept a broad range of synonyms, with methods that understand class and inheritance relations and can deal with combinations of attributes. The underlying problems of semantic representation can be found in all industries. AEC practitioners should look forward to tools that leverage BIM semantics to organize content in several ways and provide users with the ability to develop customized semantic searches. For example:

- Find an automatically controlled louver window shading system that can span between six-foot-on-center mullions
- Find all products that are applied in a particular context across multiple projects

These capabilities will gradually become available. More powerful search and selection capabilities are likely to become the market distinguishers for different commercial e-business Web sites. The introduction of these capabilities will begin by 2015, but full capabilities will not yet be realized.

As noted in Chapter 2, building model authoring tools currently incorporate a variety of parametric modeling capabilities. As a result, an object with parametric rules developed for one system cannot be translated and imported into another without losing parametric behavior. This restricts the development of effective BEMs for use in different BIM tools. These restrictions will be whittled away as more complex translation capabilities are developed incrementally. BEMs that rely on fixed shape geometries, such as bathroom fixtures and door hardware, are already available, as described in Chapter 5. Future extensions will support parametrically varying alternative shapes, such as:

- Assemblies with varying layouts and shape based on context, such as structural waffle slabs or acoustic ceiling systems
- Topologically varying shapes, such as stairways and railings

Eventually, **smart routines for automatic development of 3D details** will be provided, not only for component systems (such as exterior walls, roofing systems, mechanical, electrical, plumbing, HVAC, fire protection, and the like), but also for the interfaces between component systems. Definition of the details for application of commercial building products in the contexts of particular buildings is essential for the suppliers to provide warranties for their products. For example, automatic detailing between a roofing system and various edge conditions defined by other systems will be automatically detailed, expanding the roofing system's control to address varying and complex conditions.

Today, these are still represented in drawings, with only a few explicit variations; as a result, vendor inspections are commonly required.

Many details describe the interfaces between different systems: roofing system to walls, doors, and windows in different types of wall systems, translations between material types on façades, and this makes their definition difficult. This kind of detailing is different from the parametric modeling within a single system, because it defines relationships between two (or more) different systems, each laid out with its own parametric rules. Methods for this are currently evolving, and functions will become embedded in model design tools. They will automate a great deal of repetitive design work that today requires much effort and time on the part of trade engineers to coordinate, model, and build.

#### **8.4.9 Impact on Research: Model Analysis, Simulation, and Work Processes**

The trends described in Section 8.1 were loosely grouped in the areas of process and technology. The need for research relates to both design and construction processes and to the interdependent technologies upon which BIM depends. New technology leads to process changes; and process change gives rise to new tools.

BIM and the Internet level the playing field in terms of access to building information at both the project and industry-wide levels. Information flow becomes near instantaneous, and collaboration among all concerned within a project can become synchronous, which is a paradigm change from traditional asynchronous workflows. Traditional workflows with sequential generation, submittal, and reviews of drawings—which can be iterative and wasteful due to rework—are no longer appropriate. The professional and legal constructs that have evolved in relation to these workflows are equally unsuitable for collaborative design and construction processes, with shortened cycle times and closely integrated information flows.

While academic research has a role to play in defining new concepts and measures of information flow that promote integrity and value, it is likely that trial-and-error efforts by industry pioneers—driven by practical imperatives—will be the primary source of new BIM workflows. New contractual forms, job descriptions, commercial alignments, and procurement arrangements will need to be synthesized, tested, and refined. These will need to be adapted and sometimes redefined to fit with local codes, union practices, and other controlling contextual issues. Such efforts will support and stimulate the development of new tools in both academia and industry. Some of the directions for the latter are outlined below.



Maintaining integrity across different design models (e.g., architectural versus structural versus construction) will be imperative, as changes are made to the different models by their respective disciplines. Unfortunately, in the short term, interoperability tools like the IFCs will not support coordination beyond visual inspection and the identification of physical clashes in geometry. Managing changes across different systems—involving loads (structural or thermal) or other performance relations—will become increasingly recognized as an important and limiting condition. Smart automated transactions, implemented on BIM servers, as defined in Section 3.5.2, will augment and increasingly replace the manual updates of special-purpose model views, required for synchronization. These may be automatic or resolved by an analyst. Research will need to determine the nature of the relationships between building objects that are implemented in different discipline-specific systems.

The need to develop production building code checkers and other types of customizable design review tools will lead to the recognition that hard-coding such rules is not the best way to define and implement them. As with other software applications, hard-coding generates tools that are too expensive to write and debug and are inflexible for making changes. Instead, high-level and special-purpose rule definition languages will emerge, facilitating the general development of rule-checking in buildings (Eastman et al. 2009). At first, they may deal with simpler application areas, such as circulation and spatial assessment (Lee 2010). Subsequently, enhancements will allow for the incremental assessment of different building domains, as the standards for representing the tested conditions are defined, in IFC or related building models. These languages will allow nonprogrammers to write and edit checking rules in a more direct manner. Two types of back-end tools may be implemented to interpret and run the same languages: (1) for implementation as a standalone checker, possibly on a Web server; and (2) embedded directly into a BIM design tool, allowing checking while designing. The development of these languages would facilitate the implementation of design assessment tools in a wide variety of areas, for different building types, a range of clients, and for building code agencies.

Research is needed to address the various types of model geometry needed for different types of analyses. While most people are familiar with the need for stick models for structural analysis, few are aware of the need for tessellation structures of single bounded surfaces to represent separately managed energy zones within a building. Automatic methods for tessellation are needed for pre-processing models for energy analysis. Another type of geometric abstraction will be necessary for enclosing spatial volumes for computational fluid dynamics. Such models use heuristics to determine which geometric features are required

for capturing essential air flows. Further development of automated geometry abstractions is needed if these analyses are to move into everyday use.

Research on the integration of multiple types of analysis, as well as the development of new types of energy systems and the need to analyze them, will lead to a new generation of energy simulation tools. For example, to show the interaction of heat flows with natural convection, the output from a simulation of energy radiation to internal materials within a space will be used as input for a computational fluid dynamics (CFD) model. On the equipment side, the need to integrate smart electrical grid capabilities, where the utility companies manage the level of power provided to buildings, with local renewable energy systems, such as photovoltaics, will require a new generation of modeling tools to model their behavior. The new tools will be modular so that mixes of different types of energy-producing and energy-consuming systems can be modeled. Multicriteria optimization methods are available, such as genetic algorithms of various kinds, but utility functions that can express the integrated performance of buildings with respect to different functions will be needed. Developing these relationships would allow parametric models to automatically vary to search for performance objectives dealing with weight, solar gain, energy use, and other objectives. This would enable new levels of comprehensive performance-based design for example at the mechanical equipment level and the building envelope level that are not possible today.

In the same way that semiconductor fabrication plants undertake for-hire chip fabrication, prefabrication plants for construction may support custom numerical control (CNC) fabrication with little or no manual input for precast concrete, steel welded systems, and a few types of exterior carbon fiber reinforced plastics. Fabrication plants will rely on model data provided by the designers to generate CNC instructions, needing only minimal checking by the component producer. This will reduce the costs associated with custom fabrication, bringing them closer to that of standard construction and spreading their capital investments over many projects. “Contour crafting” and “concrete printing,” which both use rapid prototyping/additive manufacturing technologies to fabricate building components, may reach maturity within this timeframe for unique components. The latter method uses advanced concrete materials and can produce components in a build volume of up to  $2\text{ m} \times 2.5\text{ m} \times 5\text{ m}$ , of the kind shown in Figure 8–7 (Buswell et al. 2007).

Another area of research that is already of interest addresses the practical question of how to determine the best methods for delivering model data directly to the *work face* at construction sites. This research concerns hardware, software, database architectures, and human-machine interfaces. Although PDAs, tablet PCs, and mobile phones are all widely available and

**FIGURE 8-7**

The Freeform Concrete Construction research project at Loughborough University (see [www.buildfreeform.com](http://www.buildfreeform.com)) is investigating the potential large-scale additive manufacturing has for producing full-scale building components.

(Buswell et al. 2007).

will become increasingly useful for presenting BIM information onsite, paper documents are still the most common technology in use today.

The trend toward use of laser scanning for acquiring geometry in the field for use in design, outlined in the previous section, is still hampered by the high cost of interpreting the point clouds and generating meaningful building objects that can be used in a building information model. This is a time-consuming endeavor that limits the technology's use, and it is already the focus of industrial and academic research (Brilakis et al. 2010)

Lastly, throughout the period during which basic BIM research and development was pursued, the research community generated many conceptual applications for building models that could not be implemented in practice, because the BIM tools were not mature enough or in widespread use. Examples include: automated control of construction equipment, such as cranes, robotic pavers, and concrete surface finishers; automated data collection for performance monitoring; construction safety planning; electronic procurement and logistics; and many others. While there are still hurdles to overcome—for example, how standardized building products and services can be modeled for use in multiple BIM environments and comprehensive modeling capabilities for cast-in-place reinforced concrete—implementation of some of these applications may become commercially viable once building information models for construction management are more common.

#### 8.4.10 Vision 2015: The Limitations

Given the relative inertia of the construction industry and its highly fragmented structure (Chapter 1), BIM adoption will not be complete by the end of this

timeframe. Paper drawings—or at least 2D drawing formats which can be communicated electronically—will remain common forms of construction documentation. Indeed, full adoption of BIM in any firm requires two to three years to become effective. Thus, while it is unlikely that significant industry-wide productivity gains will be observed by 2015, measurable reductions can be expected in the costs of construction. Local effects may be dramatic; building forms once considered impractical—due to either technical or budget constraints—will become common. Successful early adopters in both design and construction will profit from their foresight until the rest of the industry catches up.

---

## 8.5 DRIVERS OF CHANGE AND BIM IMPACTS UP TO 2020

In looking beyond the five-year horizon, we start by identifying both the drivers for change that are likely to motivate people and organizations involved in building construction and the obstacles they are likely to face. With these in mind, we have tried to assess developments in the areas of BIM technology, the ways in which building information is delivered, design services, building product specifications, code-checking, construction management practices, employment, professional roles, and the integration of building information into business systems.

### 8.5.1 Economic, Technological, and Societal Drivers

There are a number of economic, technological, and societal factors that are likely to drive the future development of BIM tools and workflows. These will include: globalization, specialization, international drives for sustainability, and the commoditization of engineering and architectural services; the move to lean construction methods, the increasing use of design-build and integrated project teams; and the demand for facility management information.

Globalization resulted from the elimination of barriers to international trade. In construction, the possibility of moving the production of building parts to more cost-effective locations will increase demand for highly accurate and reliable design information, so that pieces can be shipped great distances with a high degree of confidence that they will fit correctly when installed.

Specialization and commoditization of design services is another economic driver that will favor BIM. As niche skills, such as producing renderings or performing sets of structural analyses, are better developed and defined—and long-distance collaboration more accepted—BIM will enable the delivery of special services.

Sustainability introduces new dimensions to the costs and values of buildings and construction. The true costs of building and facility use, when looked

at from worldwide sustainability issues, have not yet been brought to the marketplace. The pressure to make all residences zero net energy usage, and the push to make larger facilities energy producers rather than consumers, will grow. These will affect the pricing of materials, of transport costs, and the ways in which buildings are operated. Architects and engineers will be tasked with providing much more energy-efficient buildings that use recyclable materials, which means that more accurate and extensive analyses will be needed. BIM systems will need to support these capabilities.

Design-build construction projects and those delivered using IPD contracts demand close collaboration between the design and construction functions. Such collaborations will drive the adoption and development of BIM. Finally, the commercial interests of software vendors and competition between them are fundamental drivers that will compel the enhancement and development of BIM systems.

Perhaps the most important economic driver for BIM systems and their adoption will be the intrinsic value that their quality of information will provide to building clients. Improved information quality, building products, visualization tools, cost estimates, and analyses lead to better decision-making during design and less waste during construction, reducing both first costs for construction and lifecycle costs. Together with the value of building models for maintenance and operations, a snowball effect is likely, where clients demand the use of BIM on their projects.

Technical progress in computing power, remote sensing technologies, computer-controlled production machinery, distributed computing, information exchange technologies, and other technologies will open new possibilities that software vendors will exploit to their own competitive advantage. Another technical area that may introduce further developments that influence BIM systems is euphemistically referred to as *artificial intelligence*. BIM tools are convenient platforms for a renaissance of expert system developments for a range of purposes, such as code checking, quality reviews, intelligent tools for comparing versions, design guides, and design wizards. Many of these efforts are already underway but will take another decade to become standard practice.

Information standardization is another driver for progress. Consistent definitions of building types, space types, building elements, and other terminology will facilitate e-commerce and increasingly complex and automated workflows. It can also drive content creation and aid in the management and use of parametric building component libraries, both private and public. Ubiquitous access to information, including component libraries, makes the use of computable models ever more attractive for a wide variety of purposes.

The increasing power of mobile computing, location, identification and remote sensing technologies (GPS, RFID, laser scanning, and so forth) will allow for greater use of building information models in the field, which will enable faster and more accurate construction. GPS guidance is already an important component of automated earthworks equipment control systems; similar developments can be expected in construction.

### 8.5.2 Obstacles to Change

As a counterpoint to the drivers mentioned above, BIM faces numerous obstacles to progress. These include technical barriers, legal and liability issues, regulation, inappropriate business models, resistance to changes in employment patterns, and the need to educate large numbers of professionals.

Construction is a collaborative endeavor, and BIM enables closer collaboration than CAD; however, this will require that workflows and commercial relationships support an increase in the sharing of both liabilities and rewards. BIM tools and IFC file formats do not yet adequately address support for the management and tracking of changes to models; nor are contract terms sufficiently developed to handle these collective responsibilities.

The distinct economic interests of designers and contractors are another possible barrier. In construction business models, only a small portion of the economic benefits of BIM now accrues to designers. The major payoffs will go to contractors and owners. A mechanism does not yet exist for rewarding designers who provide rich information models directly (although the Sutter Medical Center case study reported in Chapter 9 appears to show this happening indirectly). Similarly, the necessary business and contractual arrangements for performance-based design, likely associated with formal commissioning, have not yet been worked out.

BIM developers cater specifically to the design professions, because of their large numbers. However, the challenge for BIM is the increasingly specialized software needed for specialized functions, ranging from project feasibility evaluation (such as DProfiler) to concept design, but especially to different contracting and fabrication systems. The development of BIM software is capital-intensive and software vendors will have to assume the commercial risk of developing sophisticated tools for construction contractors. Consortiums that aggregate the market in special niches, such as the Precast Concrete Software Consortium (Eastman 2003), may emerge to provide the necessary concentration of purchasing power and capital to enable these investments.

The major technical barrier is the need for mature interoperability tools. Moore's Law in practice suggests that hardware will not be a barrier, and this appears to be the case. The development of standards has been slower than

expected, largely because there is a lack of a business model that will allow its funding to be addressed in a capitalist economy. Industry groups such as the AISC, PCI, and the AGC are slowly recognizing this need, and it will be interesting to see if other industry groups step up to this challenge. Meanwhile, the lack of effective interoperability continues to be a serious impediment to collaborative design.

### 8.5.3 Development of BIM Tools

What effect will these trends have on the future development of BIM tools? Apart from improvements to the human-machine interfaces that can be expected of any software, BIM looks forward to seeing tools with significant enhancements in the following areas:

- Improved import and export capabilities using protocols like IFCs. The market will demand this, and software vendors will comply. But given their commercial interests, they will also pursue a second option: each BIM platform will expand its repertoire of applications, enabling increasingly complex buildings to be designed and built using a family of related tools built on the same platform without the need for data translation and exchange. This will place increasing emphasis on the foundation quality of the different BIM platforms and highlight systematic weaknesses that are already apparent.
- “Lite” BIM tools for specific building types, such as single-family residential housing, have been available for some time. If their data can be imported to professional BIM tools, they may reach a point where owners are able to virtually “build” their dream buildings or apartments and then transfer them to professionals for actual design and construction.
- There will be movement away from desktop applications to Internet-based applications that run on a thin-client format. These applications will provide front-end services for back-end BIM model servers. The software geometric modeling libraries for these technologies are already emerging. A new generation of BIM tools will support “design anywhere,” including tablet and smart-phone application interfaces.
- BIM tools that support products involving complex layout and detailing are also expected to come to market, in much the same way that HVAC equipment companies developed software in the 1980s for selecting system components (e.g., Carrier, Trane). These specialized tools will experience widespread use, because they can potentially carry special product warranties that are only honored if the product is detailed using

these tools. The degree of success or impact that these applications will have is not yet evident.

- 4D scheduling software will support simulation extensions for working out detailed assembly, installation, or erection procedures. Virtual planning tools, such as Delmia (Huang et al. 2009) are already used to perform virtual “first-run studies” in aerospace and manufacturing. These will allow the contingency fees for some custom detailing work to be reduced.

#### **8.5.4 Role of Drawings**

Drawings are fundamentally paper-based in format. Drawing symbols and formatting conventions have evolved primarily because paper is a two-dimensional medium; orthographic projections were essential for measuring distances on paper. If and when digital displays become sufficiently cheap and flexible to suit the conditions of work onsite, paper printouts of drawings will likely disappear. Once formal drawings are no longer printed, there will be no clear reason to maintain their formatting conventions. In the face of the superior medium of 3D building information models, they may finally disappear altogether, giving way to printouts that reflect special projections, such as exploded isometrics, that can be used to guide work more effectively.

In the design domain, visualization formats will replace drawing types, with different formats developed for each of the parties involved: owners, consultants, bankers and investors, and potential occupants. These formats may include standard walkthrough views with audio and possibly tactile feedback added to the visual content. User-controlled walkthroughs will support further interrogation of the model. For example, a client may want spatial data or a developer may want to query rental rates. Integration of these services into the fee structure will add value to architectural services.

#### **8.5.5 Design Professions: Providing New Services**

Increasingly, the need for information-rich i-Rooms to provide collaboration and planning spaces for construction will be responded to by multiple organizations. Architects, contractors, and possibly third parties, will provide the integration environments needed for modern practice. This includes: multi-screen conference rooms, supporting parallel projection of physical design, schedules, procurement tracking, and other aspects of project planning. Competition will determine which firms will provide these services in the future. Low-cost “CAVEs” and additional levels of fidelity will continue to expand the hardware market.

Most projects will be managed in a federated manner on BIM servers, with separate models dealing with the scope of expertise for each profession. Better coordination tools will be available for maintaining consistency across



federated model sets, but the role of *model manager* will be as essential as any other professional service. Models will support a growing number of analyses run on derived views for energy, structures, acoustics, lighting, environmental impacts, and fabrication. They will also support a variety of automated checks such as building codes, material design handbooks, product warranties, functional analysis of organizational operations within the structure, and operations and maintenance procedures.

### 8.5.6 Integrated Design-Build Services and Agreements

Another possible area of innovation is a more explicit definition of workflows for supporting project development and completion. Workflow planning will be part of most large contracts; the pass-offs, with content specifications and levels of detail will be the new “milestones.” An option provided by the workflow exchanges defined in the National BIM Standard is that they will be referred to in contracts—describing which information flows will be used, at what stages of the project, and who they will be exchanged between—based on a working process agreed to during contract negotiations. This outline of the work plan will make the collaboration model explicit and determine when engineering consultants, fabricators, and others will become involved. Such an agreement will, in turn, affect staffing requirements for each party for the project’s duration and provide a workflow of the project that can be tracked and eventually supported by additional automation.

Performance-based design contracts will become more common. Large, smart, clients will begin to specify first year energy and other lifecycle costs as performance metrics, but these will still be the exception. New consortiums of business will form to respond to the new challenges.

### 8.5.7 Building Product Manufacturers: Intelligent Product Specs

As BIM becomes ubiquitous, designers will prefer to specify building products that offer information to be inserted directly into a model in electronic form, including hyperlinked references to the suppliers’ catalogs, price lists, and so forth. Rudimentary electronic building product catalogs available today will evolve into sophisticated and intelligent product specs, including information that enables structural, thermal, lighting, LEED compliance, and other analyses, in addition to the data now used for specifying and procuring products. The ability of some products to support their direct use in simulation tools, especially lighting and energy analyses, will become important extensions to their current challenge of geometric integration. The interesting legal issues of certifying an energy component’s simulation behavior will become a new area of concern.

The basic challenges for realizing high levels of semantic search will have been addressed, and new capabilities that allow for searches based on color, textures, and shape will become available. The import and exchange of parametric objects will have become an old issue, with only fine-grained enhancements still being explored.

### **8.5.8 Construction Regulation: Automated Code-Checking**

Checking building design models for compliance with code requirements and planning restrictions is an area that will be developed further over the next ten years. This functionality could be provided in one of two ways:

- Application service providers sell/lease code-checking software plug-ins embedded in BIM software tools. The plug-in extracts local requirement data from online databases maintained by the service provider, as a service to local jurisdictions. Designers check their designs continuously as they evolve.
- External software directly checks a neutral model file, such as an IFC file, for code compliance. The designer exports the model and the check is run on the IFC model on a Web server.

Both developments are possible, although the former has an advantage for users; providing feedback directly to the model will make fixing problems easier than receiving an external report that needs interpretation before edits can be made. Because design is an iterative process—and designers will want to obtain feedback, make changes, and check again—it may be preferred.

The latter case will be required to guarantee final compliance with the code. With the proper XML link, external software can also provide input for the source BIM tool, to identify errors, and to propose corrections. In both cases, the files containing encoded planning and code requirement rules should be small and generalized format files that are easily maintained.

### **8.5.9 Lean Construction and BIM**

Lean construction (Koskela 1992; LCI 2004) and BIM are likely to progress hand-in-hand, because they are complementary in several important ways. When applied to building design, lean thinking implies: reduced waste through the elimination of unnecessary process stages that provide no direct value to the client, such as with producing drawings; concurrent design to eliminate errors and rework, as far as possible; and shortened cycle durations. BIM enables all of these goals.

The need to efficiently produce highly customized products for discerning consumers is a key driver of lean production (Womack and Jones 2003).

An essential component is the reduction of cycle times for individual products, because it helps designers and producers better respond to clients' (often changing) needs. BIM technology can play a crucial role in reducing the duration of both design and construction, but its main impact is felt when the design phase duration is efficiently collapsed. Rapid development of conceptual designs, strong communication with clients through visualization and cost estimates, concurrent design development and coordination with engineering consultants, error-reduction and automation in producing documentation, and facilitated prefabrication all contribute to this effect. Thus, BIM will become an indispensable tool for construction, not only because of its direct benefits but because it enables lean design and construction.

Clearly defined management and work procedures are another aspect of lean construction, as they allow structured experimentation for systematic improvement. U.S. construction companies like Mortenson, Barton Malow, and DPR are already leading by defining standard procedures for use of BIM in their projects. Specification of a "Company Way" (inspired by the "Toyota Way") will become an essential component of success for construction companies in expanding successfully.

### 8.5.10 Construction Companies: Information Integration

The next step for construction will be the integration of specialized enterprise resource planning (ERP) software with construction building information models. Models will become the core information source for quantities of work and materials, construction methods, and resource utilization. They will play a pivotal role in enabling the collection of automated data for construction control. Early versions of these integrated systems will appear before 2015 in the form of plug-in software added to BIM design platforms. Applications for construction management that are added to architectural platforms in this way are liable to be limited in functionality, due to the fundamental differences between object classes, relationships, and aggregations needed for construction. Construction-oriented BIM platforms will have complementary limitations in the architectural design and detailing levels.

Only later will fully purpose-built applications mature. They may be developed in a combination of three ways:

- Vendors of production detailing systems will add objects to model work packages and resources, with built-in parametric functions for rapid detailing according to company practices. Built into these systems will be applications for construction planning (scheduling, estimating, budgeting, and procurement) and construction management (purchasing, production planning and control, quality control). The result will be

highly detailed models for construction management. Multiple projects will be managed in companywide setups with multiple models.

- As extensions to standard ERP systems, with specific “live” links added to BIM models. These applications will have transparent interfaces to BIM tools but remain external to them.
- As entirely new ERP applications built for construction, with tightly integrated construction-specific building model functionality as well as business and production management functions, such as accounting, billing, and order tracking.

Regardless of the route taken, far more sophisticated tools for construction management—capable of integrating functions across a company’s separate projects—will result. The ability to balance labor and equipment assignments across multiple projects and coordinate small-batch deliveries are examples of the kinds of benefits that may be achieved.

Once building information models integrated with ERP systems are commonplace, the use of automated data collection technologies, such as LADAR (laser scanning), GPS positioning, and RFID tags, will also become common, both for construction and work monitoring and logistics. These tools will replace existing measuring methods for layout of large-scale buildings; building to the model will become standard practice.

Globalization trends along with BIM-enabled integration of highly developed design and commercial information—facilitating prefabrication and pre-assembly—will cause the building construction industry to be closer aligned with other manufacturing industries, with a minimum of activity performed onsite. This does not imply mass production but lean production of highly customized products. Each building will continue to have unique design features, but BIM will enable their prefabrication in ways that ensure compatibility when all parts are delivered. As a result, foundations may become the major component of work still performed onsite.

### **8.5.11 BIM Skills and Employment: New Roles**

Because BIM is a revolutionary shift away from drawing production, the set of skills needed is quite different. Whereas drafting demands familiarity with the language and symbols of architectural and construction drawings, BIM demands a very good focused understanding of the way buildings are built. Drafting is the laborious act of expressing ideas on two-dimensional media, whether paper or screen; modeling is akin to actually building the building. Therefore, it makes sense for skilled architects and engineers to model directly, rather than instruct others to do it for them only as a matter of record. When BIM is managed as if

it is simply a more sophisticated version of CAD, its power to enable rapid exploration and evaluation of design alternatives is overlooked.

The details of building, previously approximated in the building of physical models in architecture school, is conceptually easily replaced by the virtual models offered by BIM. However, in architectural education and thinking, BIM involves new ways of thinking and new approaches to abstraction. Architecture schools are exploring these issues but major results are not yet identifiable.

Early experience in teaching BIM to undergraduate civil engineering students has demonstrated that it is much easier to learn BIM compared to learning the combined skills of preparing orthographic engineering drawings and operating CAD tools. BIM appears fairly intuitive to students, and it more closely resembles their perception of the world. If undergraduate engineering and architectural schools begin teaching BIM skills within the first years of professional training, it will only be a matter of time before design professionals are able to create and manage their own BIM models. If such education were to begin today—as it has in some schools—it would take five to ten years for BIM-savvy professionals to become commonplace in design offices and construction companies.

Until that happens, the ranks of BIM operators will likely be drawn from drafters, detailers, and designers able to make the conceptual transition. Junior staff members are more likely to transition successfully, so most design firms will maintain the split between designers and documenters. Only when designers manipulate models directly, however, will the traditional split be blurred. As with most sophisticated new technologies, those skilled in their use during early adoption will benefit from the imbalance of supply and demand, and they will command premium salaries. This effect will mitigate over time, although in the long term, greater productivity through BIM will cause the average wage of building design personnel to rise.

Naturally, as the years pass, interfaces will become more intuitive, and construction professionals who have grown up with SimCity® and other gaming environments will be better equipped to operate BIM systems. At that point, designers modeling directly will become prevalent.

While these roles are directly centered on current BIM tools, the workbench environment enabled by integrating sustainability, cost estimation, fabrication, and other technologies with BIM tools will lead to new kinds of specialized roles. Already, energy-related design issues are commonly dealt with by specialists within a design team. Value engineering with new materials is another example. In these cases, we will see many new roles emerge in both design and fabrication. They will address the growing diversity of specialized issues that a generalist designer or contractor cannot address, and this will lead to further subcontracting of both design and fabrication services.



# BIM Case Studies

---

## 9.0 INTRODUCTION

In this chapter we present ten case studies of projects in which BIM played a significant role. They represent the experiences of owners, architects, engineers, contractors, fabricators, and even construction crews and a facility maintenance team—all pioneers in the application of BIM. Six of the case studies are new to this edition. The case studies listed in Table 9–1 represent a broad range of buildings for different functions including medical, residential, offices, retail, music, and commerce. There are also case studies of a sports stadium and a bridge.

Taken as a whole, the case studies cover the use of BIM across all phases of the facility delivery process (as shown in Figure 9–1) by a wide range of project participants (see Table 9–2). Each demonstrates a diverse set of benefits to various organizations, resulting from the implementation of BIM tools and processes. Table 9–3 indexes the case studies according to the benefits listed in Section 1.5 of Chapter 1. The wide variety of software used is shown in Table 9–4. Figure 9–1 and these tables are guides for readers to both compare the case studies and to quickly find those that match a reader’s specific interests.





**Table 9–2** Participant Index For The Case Studies

	9.1	9.2	9.3	9.4	9.5	9.6	9.7	9.8	9.9	9.10
Participants	Aviva Stadium	Marriott Hotel Renovation	Sutter Medical Center	Maryland General Hospital	Crusell Bridge	100 11th Avenue NYC	One Island East Office Tower	Music Center	Hillwood Commercial Project	Coast Guard
Owner/developer	•		•	•	•		•	•	•	•
Architect	•	•	•		•	•	•	•		•
Engineer	•	•	•		•		•	•		
Contractor	•	•	•	•	•		•	•	•	
Subcontractor/ Fabricator	•	•	•	•	•	•	•	•		
Facility Operations/End users				•				•		•

**Table 9–3** Benefits Checklist for the Case Studies (The benefits correspond to the list in Section 1.5, Chapter 1.)

		9.1	9.2	9.3	9.4	9.5	9.6	9.7	9.8	9.9	9.10
Project Phase	Benefits	Aviva Stadium	Marriott Hotel Renovation	Sutter Medical Center	Maryland General Hospital	Crusell Bridge	100 11th Avenue NYC	One Island East Office Tower	Music Center	Hillwood Commercial Project	Coast Guard
Feasibility study (Chapter 4)	Support for project scoping, cost estimation	•		•						•	•
Concept design (Chapters 4 and 5)	Scenario planning	•		•					•	•	•
	Early and accurate visualizations	•	•	•			•		•		
	Optimize energy efficiency and sustainability										
Integrated Design/ construction (Chapter 5)	Automatic maintenance of consistency in design	•	•	•		•	•	•	•		•

(Continued)

**Table 9-3** (Continued)

		9.1	9.2	9.3	9.4	9.5	9.6	9.7	9.8	9.9	9.10
Project Phase	Benefits	Aviva Stadium	Marriott Hotel Renovation	Sutter Medical Center	Maryland General Hospital	Crusell Bridge	100 11th Avenue NYC	One Island East Office Tower	Music Center	Hillwood Commercial Project	Coast Guard
Construction execution/ coordination (Chapters 6 and 7)	Enhanced building performance and quality	•	•	•	•	•	•	•	•	•	•
	Checks against design intent			•		•			•	•	•
	Accurate and consistent drawing sets	•	•	•		•	•	•	•	•	•
	Earlier collaboration of multiple design disciplines		•	•		•	•		•	•	•
	Synchronize design and construction planning	•	•	•		•	•	•	•		
	Discover errors before construction (clash detection)		•	•		•		•	•		
	Drive fabrication and greater use of prefabricated components	•	•	•		•	•				
	Support lean construction techniques		•	•	•	•					
Facility operation (Chapter 4)	Coordinate/ synchronize procurement		•	•	•	•	•				
	Lifecycle benefits regarding operating costs		•		•				•		
	Lifecycle benefits regarding maintenance				•						•

**Table 9-4** Checklist of Commonly Used Software for the Case Studies

		9.1	9.2	9.3	9.4	9.5	9.6	9.7	9.8	9.9	9.10
		Aviva Stadium	Marriott Hotel Renovation	Sutter Medical Center	Maryland General Hospital	Crusell Bridge	100 11th Avenue NYC	One Island East Office Tower	Music Center	Hillwood Commercial Project	Coast Guard
Application Area	Software Tool										
BIM Model Generation Tools											
Architecture	ArchiCAD										•
	Bentley Architecture*	•									
	Digital Project						•	•			
	ONUMA Planning System										•
	Revit Architecture		•	•							
	Bentley Generative Components	•									
	DProfiler									•	
	Structural	Revit Structures			•						
Tekla Structures				•	•	•			•		
MEP	CAD Duct			•	•						
	CAD MEP			•	•						
	Revit MEP										•
	MagicCAD								•		
BIM-Related Tools											
2D	AutoCAD	•	•	•		•	•	•	•		•
	SprinkCAD			•							
3D	Autodesk Architecture								•		
	StrucSoft Metal Wood Designer			•							
	ProSteel		•								
	Rhino	•					•				
	Fabrication	CATIA						•			
SolidWorks							•				

(Continued)

**Table 9-4** (Continued)

		9.1	9.2	9.3	9.4	9.5	9.6	9.7	9.8	9.9	9.10
Application Area	Software Tool	Aviva Stadium	Marriott Hotel Renovation	Sutter Medical Center	Maryland General Hospital	Crusell Bridge	100 11th Avenue NYC	One Island East Office Tower	Music Center	Hillwood Commercial Project	Coast Guard
Database	Excel	•				•					
	ProjectWise			•							
	Vela Installed				•						
	Equipment data										
Analysis Tools											
Structural	RAM										
	Robot Millenium	•					•				
	Strand						•				
	ETABS			•							
Estimating	DProfiler									•	
	Sage Timberline			•							•
	Innovaya			•							
	Vico Cost Est.								•		
Scheduling	Strategic Project Solutions			•							
	Vico Control					•					
Coordination	Navisworks	•	•	•		•					•
	Newforma		•								
Rule-Checking	Solibri							•			
Survey Control	Trimble RealWorks					•					
Laser Scanning	Cloudworx		•								
Energy	TraneTrace		•			•					

\*Bentley Architecture and Bentley Structures are based on the Microstation Triforma platform.

No single project has yet realized all or even a majority of BIM's potential benefits, and it is doubtful that all of the benefits that the technology enables have been discovered or even identified. Each case study presents the salient aspects of the BIM process and focuses on the ways each team used the available tools to maximum benefit. We also highlight the many lessons that these

teams learned as they encountered challenges in implementing the new technologies and processes.

Many of the projects were in progress at the time of writing, preventing a full review or complete assessment of the benefits. Naturally, research was limited to the availability of various participants and their willingness to disclose information. Architecture, engineering, construction, fabrication, and real estate development are competitive fields, and organizations are often reluctant to disclose their enterprise expertise. Nevertheless, most organizations and individuals were extremely helpful and made significant efforts to share their stories and provide images, information, and important insights. We have tried to identify the key issues of each project, not just success stories, but also the problems that had to be solved and the lessons learned from dealing with them.

---

## 9.1 AVIVA STADIUM

### *Parametric Modeling for Design and Fabrication of a Unique Stadium Shell*

#### 9.1.1 Introduction

The history of the Lansdowne Road Stadium in Dublin, Ireland, started in 1872 as result of the efforts of Henry Wallace Doveton Dunlop, a young Irish athlete who envisioned a place especially dedicated to host several sporting events. In 1876, it became the first international rugby stadium in the world and was continuously used as such since then. During the 1970s the stadium started to host soccer matches as well. The original Lansdowne Road Stadium had a capacity of 49,000 spectators for rugby and 36,000 spectators for soccer games. Over its long lifetime, residential areas of Dublin have grown to surround the stadium, and new requirements for international rugby and soccer matches have made it obsolete.

The new Aviva Stadium (named after the Aviva Group insurance company, which signed a ten-year contract for the naming rights) has been designed to replace the old structure, providing a state-of-the-art venue seating 50,000 spectators. It was designed by Populous, one of the leading sports venue architectural firms in the world, together with the firm Scott Tallon Walker. Similar to the old stadium, Aviva Stadium allows for both soccer and rugby matches. The new stadium and the main pitch (playing field) are oriented North-South, generally in the same orientation as the existing stadium. The most distinctive feature of the new stadium is its semi-transparent “shingled” organic skin which wraps the entire stadium bowl. The roofed part of the skin covers all the

seating tiers while providing optimum levels of natural light for both the pitch and the surrounding neighborhood.

The construction of the new stadium began in May, 2007 and it is now complete. The case study demonstrates the use of BIM to realize an innovative freeform design. Our focus is on the development of a parametric model that supported the definition of the stadium's skin and structure and how it was used to manage their fabrication and erection.

### 9.1.2 Project Overview

The new Aviva stadium design consists of a continuous curvilinear-shaped envelope enclosing all four sides of the stadium bowl and the roof. It rises to a height of just under 50 meters (164 feet), allowing the south, east, and west stands to have four tiers of seating for spectators. The north stand has only one low-level seating tier, to minimize the impact over the residential neighborhood adjacent to that side of the site.

The total project cost is an estimated €410 million (U.S. \$530 million). The original client for this project was the Lansdowne Road Stadium Development Company (LRSDC). This company was created by the Irish Rugby Football Union and the Football Association of Ireland in 2004 in order to fulfill an agreement made with the Irish Government for the construction and management of the new stadium.

The project team consisted of three types of professional groups: designers, project managers, and consultants (Table 9-1-1). On April 25, 2005, LRSDC appointed Populous Architecture (formerly HOK Sport Venue Event) as lead design firm and Project Management Limited as responsible for the managerial side. Consultants were appointed separately by Populous and Project Management to assist them in different aspects of the project. On the design side, the consultants included local architects Scott Tallon Walker. Buro Happold was the structural, civil and façade engineers, and the mechanical engineers were ME Engineers Limited. On the managerial side, the main consultants were Keogh McConnell Spence (KMCS) and Franklin Sports Limited for quantity survey, cost management, and procurement.

Populous and Project Management Ltd. reported their progress to LRSDC. LRSDC submitted relevant issues on design, planning, and construction to the Project Monitoring Committee (PMC) for evaluation and approval. This committee consisted of Dublin city officials and council members as well as local community representatives and it is still active. To support the evaluation process, especially regarding the environmental impact of initial design alternatives, LRSDC appointed Environmental Resources Management Ireland Ltd. (ERM).

**Table 9-1-1** Participant Companies

<b>Project Team</b>	
<b>Client:</b>	Aviva Stadium (Previously (LRSDC)
<b>Project Director:</b>	Michael Greene
<b>Stadium Director:</b>	Michael Murphy
<b>Project Management:</b>	Project Management Ltd.
<b>Quantity Surveyors:</b>	Keogh McConnell Spence / Franklin Sports Ltd.
<b>Design and Planning:</b>	
<b>Architects:</b>	Populous and Scott Tallon Walker
<b>Structural, Civil and Facade Engineers:</b>	Buro Happold
<b>Services Engineers:</b>	M-E Engineers Ltd.
<b>Landscape Designers:</b>	Gross Max
<b>Catering Designers:</b>	Smart Design Group & QA Design
<b>Pitch Design:</b>	The Sports Turf Research Institute (STRI)
<b>Planning Consultant:</b>	Tom Philips Associates
<b>Fire Consultancy:</b>	Michael Slattery Associates
<b>Communications:</b>	WHPR
<b>Construction:</b>	
<b>Main Contractor:</b>	John Sisk and Son Ltd.
<b>Demolition &amp; Rail Corridor:</b>	McNamara Construction
<b>Substructure Subcontractor:</b>	BAM
<b>Structural Steel Subcontractor:</b>	SIAC/Cimolai JV
<b>Mechanical Subcontractor:</b>	Mercury
<b>Electrical Subcontractor:</b>	Kentz
<b>Roofing &amp; Cladding:</b>	Williaam Cox

After selection of the best design configuration, LRSDC called for an international tender competition for selection of the main contractor. The winner was the Irish firm John Sisk and Son. Sisk was responsible for subcontracting a number of other firms for specialized work. SIAC and Cimolai were the subcontractors for the construction of the steel roof structure, and Williaam Cox for cladding and roofing.

### 9.1.3 Design Requirements and Concept Development

The design of the new Aviva Stadium at Lansdowne Road required a facility with a seating capacity of 50,000 within very tight footprint limits. The main goal was to satisfy this requirement while creating an urban landmark capable of hosting international-level events. At the same time a complex set of constraints had to be managed along with environmental considerations for the construction process and building lifecycle. This series of requirements and constraints led to the development of very innovative solutions both for the architectural form and for the structural layout.

#### **Architectural Form**

During conceptual design, the team explored different stadium shapes and produced a basic set of footprint configurations. The leading idea was to wrap

the stadium with a smooth “shingled” organic skin, with a seamless continuity between façade and roof. The architects used Rhino, a multipurpose 3D modeler to quickly generate volumetric surface models of this concept and to identify the best configuration for planning approval. This process involved the evaluation of various alternatives based on four main criteria:

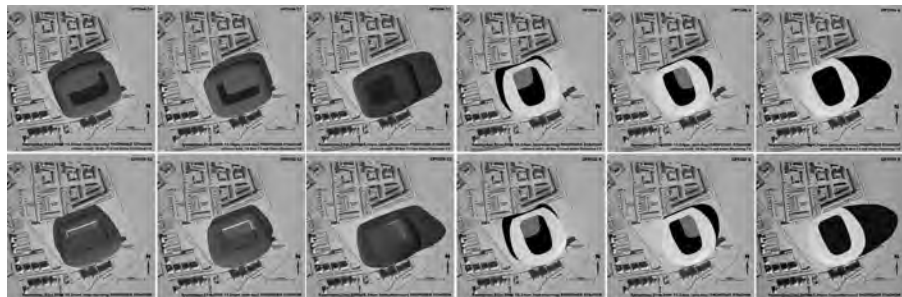
1. To ensure the required seating capacity while providing optimal sight lines for spectators and proximity to the pitch.
2. To maximize sun exposure on the pitch (playing field) for natural grass growth.
3. To minimize shadowing of neighboring houses.
4. To provide extra space for a training field and other auxiliary facilities on the east side of the site.

The team analyzed alternatives through several studies which included glare, transportation, accessibility, and emergency evacuation. Extensive daylight studies were done based on both north-south and east-west orientations. (See Figure 9–1–1.)

After a careful review, the client selected alternative A (north-south orientation leaning toward the west) as the scheme that satisfied most of the requirements while minimizing the negative impacts. To reduce shadowing on the neighborhood located to the north, the architects decided to limit the height of the stadium on that side to just one tier, while providing four tiers on the east, south, and west sides. This configuration resulted in the most distinctive feature of the stadium, producing a whole new skyline for that part of the city. Additionally, this feature allows spectators sitting on the southern side of the bowl to have impressive views of Dublin’s downtown (Figure 9–1–2).

**FIGURE 9–1–1**

Series of daylight studies to evaluate different building forms and footprint configurations.







**FIGURE 9-1-2** (Left) A view of the finished stadium. (Right) A view of approved configuration from stadium seats with Dublin skyline in background. (See color insert for full color figure.)

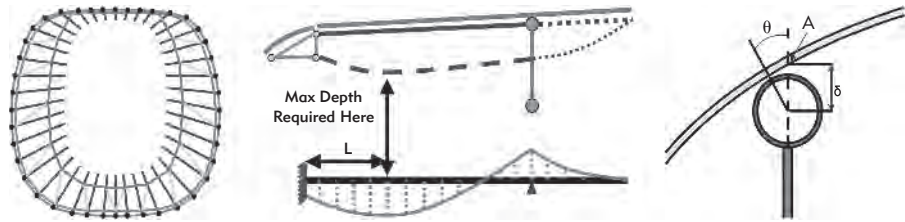
Photo credit Chris Gascoigne.

### ***Structural Layout***

The most innovative engineering aspect of this project was the design of the roof structure, developed by Buro Happold. It consisted of a complex hierarchical system of trusses featuring a primary “horseshoe” steel truss that spans around the east, south, and west tiers of the stadium. This horseshoe truss is supported at the north end by a pair of tapering concrete supercolumns and by a series of secondary spur-trusses that connect the primary truss to a ring truss that runs around the perimeter of the stadium. This ring truss is supported by columns at the rear of the tiers. Tertiary trusses then span radially between the primary truss and the ring truss, and then cantilever up to 15 meters beyond the primary truss to create the internal leading edge of the roof.

The shape, depth, and number of structural elements not only had to be determined by load-bearing conditions, but they also had to be refined so that no functional constraints would be violated. For example, sight lines at the top-level seat could be blocked if the bottom of the primary truss was too low. The shape of the bottom chord of trusses had to be circular to meet the aesthetic requirements of architects and the trusses depth also had to be limited to 4.4 meters so that they could be transported to the site from offsite fabrication shops (Figure 9-1-3).

All these functional considerations had the potential to affect the structural performance of the structure. By including them as design rules into a parametric model, optimum sizes were achieved by each individual truss while resolving many of the conflicts described above. The following section explains



**FIGURE 9-1-3** Diagram of hierarchical structural layout. The primary horseshoe truss is the inside loop; secondary ring trusses are the outside loop; spur-trusses are the diagonals between the horseshoe and secondary trusses; the tertiary cantilevered trusses project from the secondary trusses to over the pitch. Parametric rules were defined for maximum depth of trusses and spacing between cladding structure and trusses.

the collaborative process and the rationale for the development of such parametric model.

#### 9.1.4 Parametric Design and Collaboration

The design development of the project proceeded on two parallel tracks. The first was what can be considered the “core” of the stadium, that is, the main stadium structure that includes the bowl, the pitch, and all the internal spaces and facilities. The second track was the stadium cladding envelope.

Due to the complexity of the envelope design and the need for constant adjustments in its constraints, the team developed a collaborative workflow centered around parametric models using Bentley’s Generative Components (GC) software. This parametric approach meant that the geometrical configuration of the stadium could be numerically controlled, removing the need to manually edit and rebuild the geometry when a change occurred.

The strategy adopted for collaboration started by the agreement on a set of common design and modeling rules that were later embedded in the parametric models. The architects wished to retain control of the external geometry of the stadium envelope, while the engineers would design the structural system to support the envelope. A hypothetical boundary surface was discussed that separated the domain of engineering responsibility from that of the architects. The geometry of this interface layer was controlled by the architects and passed to the engineers. This allowed the manipulation of the design geometry while the structural geometry and corresponding structural analysis were triggered automatically. Based on these rules when a change in curvature was produced on a portion of the architectural surface, the structural system underneath was automatically updated and submitted for evaluation. On the other hand, if engineers changed truss sizing or the spacing between trusses, then

the architectural side of the surface and all its dependent components such as cladding panels and brackets adapted automatically as well. The design team foresaw four relevant advantages for collaboration based on this parametric approach:

1. To enhance consistency across different models by automatic propagation of design changes. All the architecture and engineering models should have the same driving configuration based on common parameters and rules. This approach also facilitated an easier generation of alternative solutions.
2. Reduce feedback cycles. To streamline the preprocessing of data required for structural analysis, reducing analysis time, and shortening feedback cycles. To satisfy this need a custom application was developed by engineers at Buro Happold to integrate GC with a software package for structural analysis.
3. To facilitate the definition and manipulation of alternative cladding systems. A dynamic link between Excel spreadsheets and GC was adopted as a friendly interface to create complex louver opening patterns. Such patterns had to have a strong aesthetic appeal and satisfy air handling unit (AHU) ventilation requirements.
4. To facilitate communication with curtain wall and roof fabricators based on exchange of simplified center-line models and schedules generated from the parametric model.

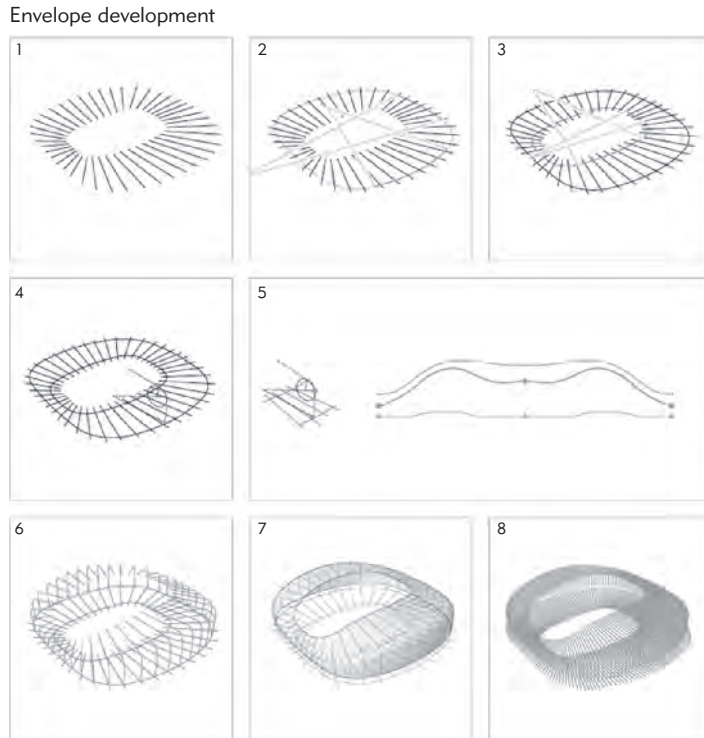
### 9.1.5 Technical Implementation of the Parametric Approach

Three modeling components were used to implement the 3D parametric model of the envelope form: (1) Numerical parameters, (2) static geometry, and (3) Generative Components (GC) scripting files. The parameters or numerical data correspond to the position of surface control points extracted from the original Rhino model and then stored in an Excel spreadsheet. This numerical data was read into GC by scripted code, which replicated the original Rhino model and automatically updated whatever changes were made to the original data points.

A graphical control system based on control curves was constructed to easily manipulate the overall geometry of the model (Figure 9-1-4). In this manner rules used for the original model to determine the overall geometry were further refined. The control system was combined with additional global constraints to form the final geometry of the envelope and then later to resolve conflicts with the stadium core. This geometric control system also facilitated

**FIGURE 9-1-4**

The envelope was set up and controlled by the following sets of curves: (1) Grid file, static geometry; (2) outer-edge setout, GC file; (3) inner-edge setout, GC file; (4) section geometry, GC file; (5) sectional height graph, numerical parameter; (6) structural definition; (7) form definition; and (8) mullions definition.



the communication between Populous and the various specialists. Potential conflicts with seating layout and sight lines were quickly checked and alternative solutions were tested in the model by manipulating these control curves.

In order to keep an appropriate spatial relationship with the design of the stadium bowl, static geometry from the different tiers was brought into the parametric environment from the Microstation CAD files in the form of external reference files. These files contained planimetric information such as the radial grid for the concrete structure of the stadium tiers, cross-sections and back-of-seating curves provided by the seating design specialists. These files were edited in Microstation and then recombined with the parametric model by transforming static geometry into GC parametric entities. Adjustments between the core and the envelope were done easily by using the graphic control system and numeric values would be updated via Excel spreadsheets.

The starting point for the geometric definition of the envelope skin and structure was an array of vertical planes that controlled the locations of the tertiary elements of the roof structure. Every plane on the array was positioned at the intersection of parametrically controlled footprint curves and the radial

structural grid of the stadium bowl. Structural bays were defined between each pair of these planes. Each plane was a spatial reference for a particular cross-section of the envelope which was then extracted and exchanged as two-dimensional cross-section drawings.

Other mechanisms for data exchange were center-line-based three-dimensional models of the entire envelope structure as well as partial structural bay models. Complementary information regarding position and dimensions of various envelope components were exported in numerical format through Excel spreadsheets.

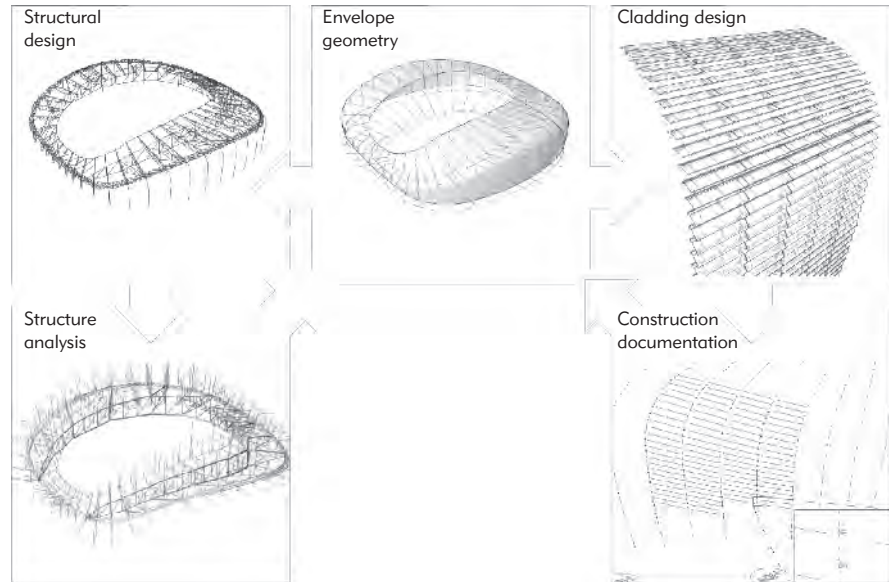
### ***Structural Analysis and Feedback***

Because the architectural model of the envelope was likely to go through a number of iterations as the design developed, it was necessary to establish a mechanism for effective communication of the design intent. For this reason the engineering team at Buro Happold decided to use the architecture parametric model as the base reference to build its own parametric model. However, the engineering model required a simplified version comprising only the center-lines of anticipated structural members, with proper offsets from the architectural model. Both models then were dynamically linked through numerical values of control points contained in Excel spreadsheets.

Buro Happold undertook the development of the structural analysis model. One of the most challenging aspects of this project was the inclusion of the engineering analysis into this parametric workflow. For that purpose a custom application was developed in-house to support the integration between the parametric model and structural analysis software. This application was created by extending the GC's internal functionality through its Application Programming Interface (API) using the C# programming language. This custom application was able to transfer information from the GC parametric model directly into Robot Millennium, a structural analysis package. The automation was achieved to such extent that the file created in Robot Millennium was ready for analysis without manual preprocessing of loading data. The program automatically specified sectional dimensions to each structural element in the model, such as truss chords, lacing members, or bracing. The initial estimation process was based on engineering assessment of loading condition and spans, which were then gradually refined during further analysis iterations. As a result, Buro Happold produced a fully parametric system capable of generating the entire stadium roof structural model from architect-driven principles and initial structural concept layout. This system was also capable of automatically generating data files ready for analysis without the need for manual intervention (Figure 9-1-5).

**FIGURE 9-1-5**

Robot Millenium structural model with input loading data.



### 9.1.6 Envelope Detailing, Fabrication, and Erection

Another important benefit provided by the parametric models (both the architectural envelope and the structural one) was the support provided for the processes of detailing, fabrication, and erection of the stadium envelope. This includes both the façade cladding and the roof structure. The main output in both cases were updated center-line models that represented a simplified geometry of the design, along with spreadsheet files containing further descriptions of section types and dimensions for linear elements. These models and their linked spreadsheet files were used by the cladding and roofing subcontractors to achieve the final results.

#### *Roof Fabrication and Erection*

One of the main design goals regarding the stadium envelope was to generate a seamless continuous surface between roof and cladding façade. Therefore, close coordination was needed between cladding and roofing fabricator. This goal was achieved by using the same center-line structural model produced by the engineering team from the parametric model as well as careful planning of the construction process.

The subcontractor chosen for the roof fabrication and erection was the Italian company Cimolai, who specializes in very large steel structures. Engineers at Cimolai used the German BOCAD fabrication and CAD/CAM application to produce all the required fabrication information directly from the center-lines

DWG model provided by Buro Happold. In this model, the specification of different section types was organized by layers which facilitated the automatic generation of connection details using customized BOCAD macros. BOCAD also supported other critical production tasks, such as materials management and part lists processing, parts nesting and NC code generation for steel laser cutting, as well as final assembly planning.

The construction process consisted of a mix of offsite and onsite methods. The leading activity was the assembly of prefabricated 25-meter-long truss segments that compose the primary horseshoe truss. These truss segments were made of welded cylindrical members which were brought to the site and individually raised by cranes. The horseshoe truss assembly sequence started at the concrete supercolumns in the north end of the stadium and proceeded southward. Temporary towers were installed at segment joints to support truss segments and connections were bolted. (See Figure 9-1-6.)

The roof horseshoe truss was released into position once all the segments of the main truss were erected and bolted together. Due to the size and nature of the roof truss the whole structure would be subject to thermal expansion and movement during its lifecycle. Thus the ends of the primary horseshoe truss rested on bearing plates and each spur truss resided onto directional slip



**FIGURE 9-1-6**

Horseshoe truss construction process. Bolted truss segments supported by temporary towers at connection joints.

bearings on the back of the bowl allowing the whole system to expand and contract in place. The implications of these deformations for the design and assembly of the cladding system are discussed in the following section.

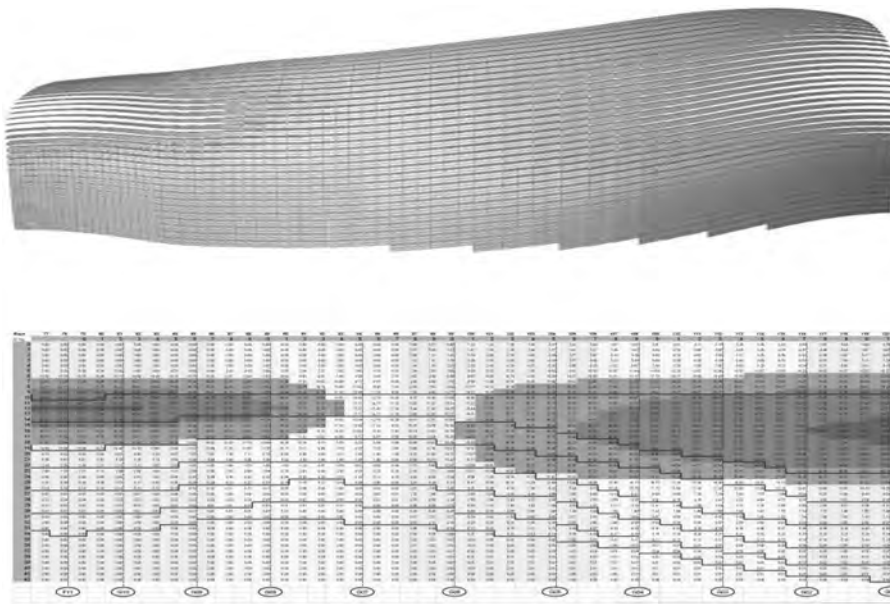
### ***Cladding Design and Optimization***

The design of the cladding consists of an array of polycarbonate louver panels that follow the curvature of the stadium envelope. The initial modeling of the cladding was made in Generative Components by parametric propagation of the panel components along the boundary-layer surface. They were generated with a constant width but variable length, with a maximum possible length specified by the panel manufacturer. In this way alignment and dimensioning of each panel was automatically adjusted by the software to fit curvature variations on the envelope geometry.

The parametric model was extended to drive the opening angles of the louvers to allow more air intake where needed according to the air handling unit system requirements. Those requirements were calculated by the service engineers so the percentage of opening on the façade was given as input. Instead of simply opening a group of louvers, the architects looked to create a more aesthetic opening pattern. In order to control the selection and layout of the opening louvers, an Excel file was used as user-friendly graphical interface to visually produce and control the intended pattern. In this way colors assigned to spreadsheet cells were converted in angle values according to a gradient formula. The parametric model could read in the spreadsheet and apply the opening angle values to every single panel of the façade (Figure 9–1–7).

The panelization pattern and opening layout required a high level of precision and optimization for detailing of the panels and connections. Due to the large size of the cladding model and the number of components required, it would be unrealistic to try to create a full parametric model of the entire stadium envelope. Instead a “divide and conquer” strategy was implemented to solve the problem regarding collaboration with the curtain wall consultants. This solution consisted in stripping-down the parametric model of the entire stadium envelope (master model) into smaller “children” models defined by the structural bays within tertiary trusses that were four panels wide. Control point information from the master model was then extracted through a scripted function and exported to Excel spreadsheets. Individual child models were created by other scripted functions that read in the spreadsheet data and rebuilt each individual bay into separated GC files (see Figure 9–1–4). In this manner the difficulty of handling a very large parametric model was solved by slicing it up into smaller manageable parts. Later, center-line versions of individual bays were sent to the cladding façade specialists as DWG files for optimization analysis and detailing.





**FIGURE 9-1-7**  
Louver opening layout.  
Graphic control through  
color-coded spreadsheet  
cells.

Clad Engineering from Switzerland served as curtain wall consultants, which had the mission of making the assessment of performance requirements and optimization of the rain-screen cladding design. The main goal was to value-engineer the cladding in order to fabricate and erect it efficiently and cheaply. Initial rain runoff analysis models were performed using the GC models in collaboration with the architects. Later new detail-level models were implemented in SolidWorks using the DWG center-line bay models as the starting point. This process involved the generation of alternatives for panel configurations and brackets. It was automated to a certain extent by using SolidWorks' specialized macros (Figure 9-1-8).

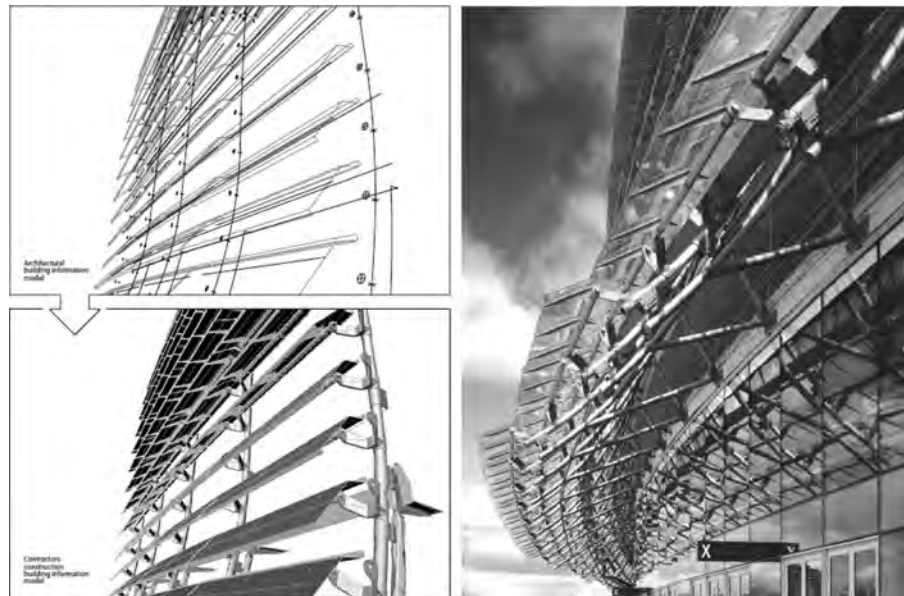
These models were used later on to perform a series of additional studies to evaluate different panel/bracket configurations. An important aspect to be considered during these studies was the anticipated lateral deformation of the curtain wall mullions due to the thermal expansion and contraction of the roof steel (see previous section). After the optimization process the final panel design was defined, and the number of different panel lengths was reduced from 4,114 to 53. Also a custom adjustable bracket was specially developed to provide extra flexibility for final cladding assembly (see Figure 9-1-8).

### ***Cladding Fabrication and Erection***

The façade skin comprises a single rain screen layer of transparent polycarbonate supported on aluminum mullions. The cladding was mainly intended to

**FIGURE 9-1-8**

Detailing of panel and brackets from definition of parametric behavior to testing and optimization. A full-scale mock model was built for testing and planning. (See color insert for full color figure.)



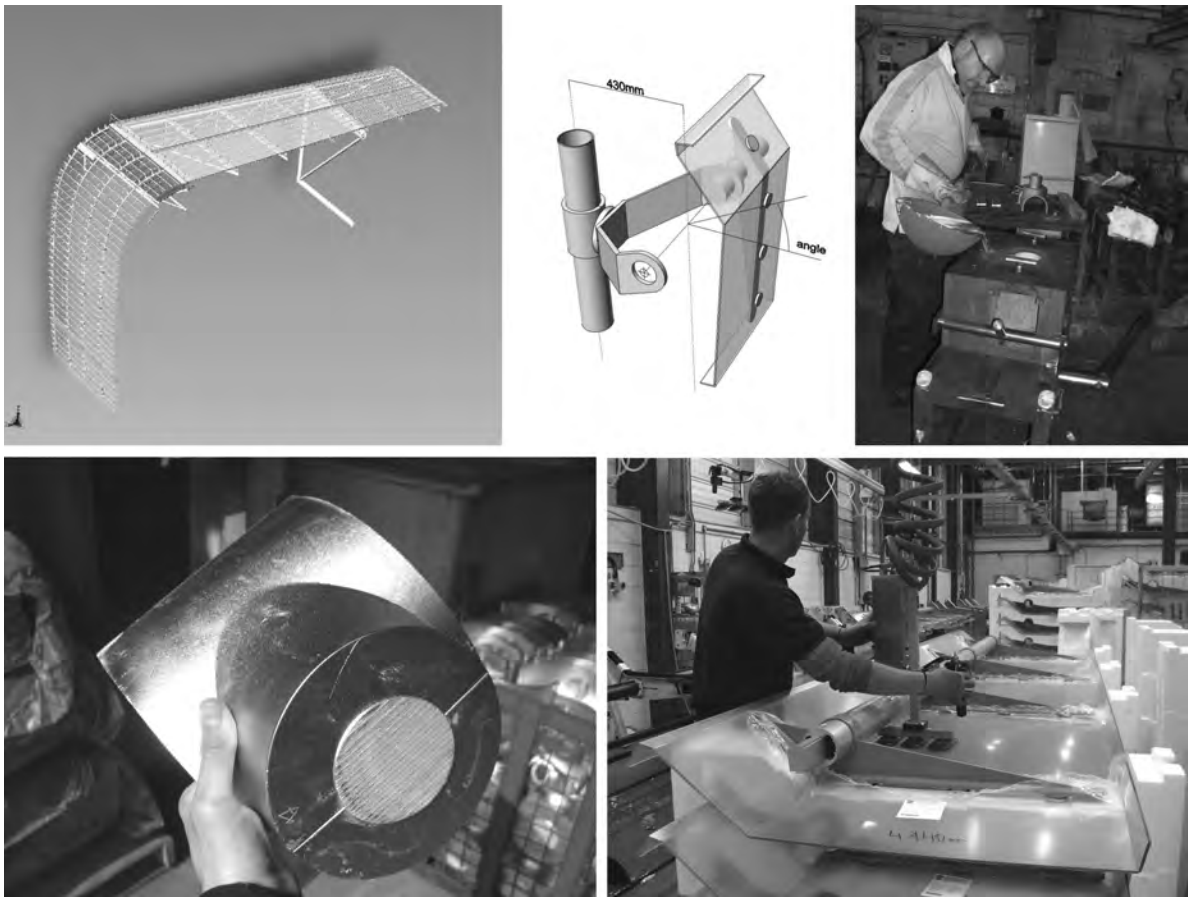
provide protection against rain but not to be sealed. Some indoor areas such as hospitality or premium spectators have conventional double-glazed façade behind the polycarbonate rain screen.

Williaam Cox was the cladding fabricator, which collaborated closely from the beginning with the architects and Clad Engineering in order to facilitate the design-to-fabrication process. This collaboration led to the design of a custom cladding façade system made of four main components: the polycarbonate louver panels, the aluminum frame for the panels, the aluminum rotational brackets, and the curved aluminum mullions (Figure 9-1-9).

The fabrication of the aluminum panel frames and brackets was done using a conventional aluminum die-casting process. For that purpose Williaam Cox subcontracted two local casting companies that were able to produce all die-cast components using information from the SolidWorks model.

For the fabrication of polycarbonate cladding panels most of the information needed was contained in Excel spreadsheets extracted directly from the parametric model. The information identified each panel within a bay, along with its specific length, orientation, and opening angle. Panel cross-sections were constant and were achieved by cold-folding polycarbonate sheets.

However, the most difficult and sophisticated process was to produce the curved mullion segments with all the predrilled holes necessary for connection with other mullion segments and the rotational brackets. The solution



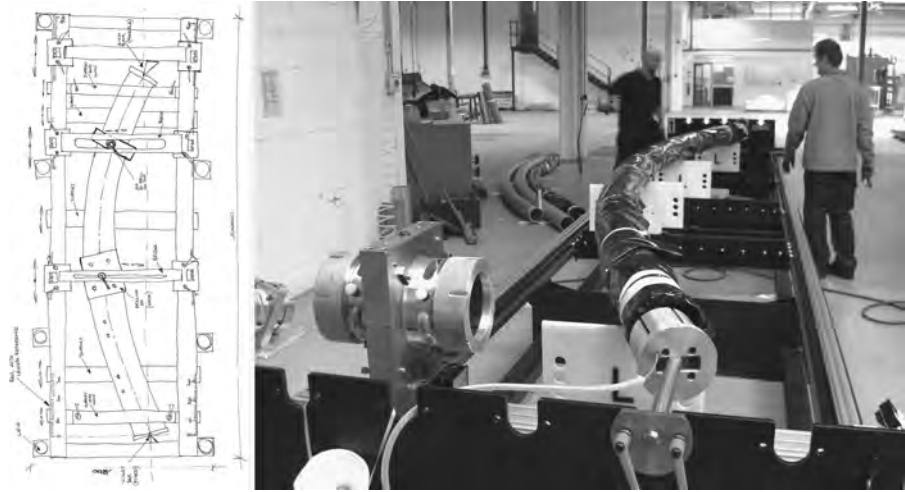
**FIGURE 9-1-9** Design-to-manufacturing process of custom cladding façade components.

was a custom rigging table especially designed by Clad Engineering and fabricated by William Cox. Extruded aluminum profiles were curved at specified radius by a rolling machine, and then brought to the rigging table for drilling. Information of each hole position and diameter was obtained from shop drawings automatically generated from the SolidWork 3D model. All the drilling was manually done following the measurements of a laser device and the guidance of adjustable jigs of the rigging table (Figure 9-1-10). Finally each mullion was identified with a bar code depicting individual bay and specific position within bays.

Final onsite assembly was greatly facilitated by the preassembly of entire mullion sections and predrilling of bracket holes. The polycarbonate louver panels and frames were also preassembled offsite and brought to the construction

**FIGURE 9-1-10**

On the left, a sketch of the rigging table proposed by Clad Engineering; on the right, an aluminum mullion being drilled on a table fabricated by William Cox.

**FIGURE 9-1-11**

Final assembly of cladding façade. Adjustable brackets and connections for matching variance on panels orientation. (See color insert for full color figure.)



site in ordered, bar-coded pallets. Only the affixing of the panels on rotational brackets (over 4,000) was done onsite to allow for more cost-effective transportation. (See Figure 9-1-11.)

### 9.1.7 Evaluation and Lessons Learned

During the design and engineering phase of the project, both design and engineering teams relied on several criteria to evaluate the design and constructability of the parametric model. Buro Happold concentrated on the evaluation of the structural design of the roof and Populous focused on evaluating the aesthetics, performance, and practicality of the envelope design. An explicit 3D surface demarcated the location and entities defining their coordination.

From the structural design side, the two most important lessons were benefits of parametric modeling for collaboration with architects and the great advantages that can be achieved through customization of software applications. The complex nature of the doubly curved envelope geometry and its truss system implied that huge amounts of calculations had to be carried out every time the architecture model changed. To perform these tasks using traditional manual input would be prohibitively time-consuming, tedious, and prone to error. However, this problem was avoided by the custom integration of the parametric modeling and the structural analysis application. This solution not only allowed the automatic preprocessing of geometric and loading information directly from the architectural model, but also supported the inclusion of wind coefficients from wind-tunnel testing. At the end, engineers at Buro Happold were able to generate an entire set of 51 loading scenarios ready for analysis with no need for manual intervention. The drastic reduction in design-analysis feedback cycle validated the efforts of developing this custom application. This approach proved to be very cost-effective and likely to be adopted in future similar projects.

From the architectural side, great benefits were obtained by the use of parametric modeling as well. The most important was the achievement of the design goals for the envelope cladding by exhaustive generation and testing of alternatives. Early studies explored different panelization schemes, based on fixed and variable panel dimensions. Additionally, planar and twisted panels were assessed from both a construction perspective and in terms of visual impact. Custom-defined tools were created in the parametric modeling environment to evaluate rain drainage directions and to flag panels that exceeded the manufacturer's specifications. Further collaboration with cladding consultants and fabricators led to the drastic reduction in the number of different panel lengths, from 4,114 to only 53. In this way the parametric model and the collaboration it supported between architects and fabricators led to a highly value-engineered cladding system optimized to be produced and installed at low cost.

Only the fixing of the panel within the façade-holding bracket and the fixing of the mullion to the building frame were done onsite to allow for fine adjustments. These adjustments were anticipated and necessary to absorb movement and deformation through lateral expansion and contraction of the concrete frame. The adjustments also accepted the vertical movement during the assembly and support removal sequence of the main steel work as it shifted into its final position. The façade, once in its final position, is then subject to both lateral and vertical movement from live thermal expansion and contraction of both the concrete and steel frames and live deflections of the

concourse floors. The lesson learned here is that the final model generated for fabrication needs to be the as-built model, based on full anticipation of temperature, gravity, and other loads—and in this case, assembly processes.

One of the most fundamental lessons from this experience is the potential to capture relevant expertise from designers, consultants, and contractors alike and to embed it in the form of parametric rules. These rules then can be used for quick generation and evaluation of alternatives within valid ranges defined by the specialists.

### 9.1.8 Conclusions

Parametric modeling is a fundamental technology behind BIM. The architecture–engineering partnership created for the Aviva Stadium is an excellent example of how this technology was used to support a highly collaborative design process to generate innovative outcomes. This collaboration was built upon an agreement of common rules that defined and controlled the geometric behavior of relevant building objects. These rules reflected the unique design and engineering expertise of the team members. The parametric modeling expertise to integrate the various kinds of talent was the keystone for the achievement of a cost-effective solution.

Throughout this project’s design and engineering process, many advantages were realized and lessons learned from using a parametric model for the design. Of all the advantages, the most obvious was noted to be the flexibility of the parametric model, relating to being able to be edited and distributed efficiently between Populous and Buro Happold, as well as to the roof and cladding consultants and fabricators. This allowed rapid and relatively easy changes to the model, hence reducing evaluation and feedback cycles. Good working relationships between architects and engineers contributed to the success of this approach.

At the same time, some disadvantages were identified as well. Advanced modeling skills were required for the development and modification of the parametric models which resulted in only few members having a working understanding of the models. These highly specialized skills are currently relatively unique within the industry. However, it is being taught in architecture schools and is becoming more widely used in offices in the AEC industry. This recent trend will certainly help to reduce bottlenecks in the workflow and stimulate the development of richer and more sophisticated models and their resulting buildings.

In general, similar projects would greatly benefit if other specialists and consultants are integrated early in the design process. Even though it is not necessary that all subcontractors have skills in parametric modeling, their domain expertise should be considered and incorporated into the formalized

rules to define new custom capabilities. Such an initiative certainly improves the collaboration through early identification of constructability and fabrication issues, as well as reusability of expertise embedded in previous parametric solutions. These observations have obvious implications on current delivery methods and contractual models.

## Acknowledgments

This case study was originally developed by Andres Cavieres and aided by Evangelos Yannas for Professor Chuck Eastman in a course offered in the College of Architecture Ph.D. Program at the Georgia Institute of Technology, Spring 2008. It has been adapted and updated for use in this book after completion of the Aviva Stadium. The authors wish to acknowledge and thank Paul Shepherd and Roly Hudson of University of Bath, and David Hines from Populous, whose contributions and insights were very important to this case study. The images are courtesy of Populous, Paul Shepherd, and Roly Hudson.

---

## 9.2 COURTYARD BY MARRIOTT

### *Use of BIM in Remodeling and for LEED Certification*

#### 9.2.1 Project Overview

The Toronto National Building was built in 1982, but sat unused in the heart of Portland's business district for nearly two decades. In 2009, it was finally occupied, after being transformed into a contemporary hotel, the Courtyard by Marriott (Figures 9-2-1 and 9-2-2), designed by SERA architects. The major participants are shown in Table 9-2-1. Three new floors were added to the existing thirteen-story building, the entire façade was removed and replaced with a new one, new systems were added to match the hotel needs, and the existing structure was upgraded according to the new structural loads and current building codes. An adjacent three-story building was demolished and replaced with a new four-story structure that provided parking, public functions, and back-of-house activities.

The project was awarded the Leadership in Energy and Environmental Design (LEED) Gold certification from the U.S. Green Building Council,

**FIGURE 9-2-1**

Main entrance visualization.

**FIGURE 9-2-2**

Multi-hotel model in Revit.



because its energy efficiency, low water consumption, low carbon emissions, high-quality indoor environmental conditions, and efficient use of resources.

Probably the most radical project design decision was the choice of building restoration over demolition. This decision, motivated by the desire to minimize the use of resources, brought a series of challenges in terms of integration of new systems into the existing structure. A complete 3D scan of the building allowed the development of a precise and reliable geometric description. This was the main source of information for a family of consistent BIM models for



**Table 9–2–1** Project Overview**Type of Project:** Renovation of office building into hotel**Location:** 300 SW 6th Avenue, Portland, OR**Primary team****Owner:** Sage Hospitality**Architect:** SERA Architects**General Contractor:** Hoffman Construction Company**Structural/Civil Consultant:** KPFF**MEP Consultant:** TGA**Subcontractors****MEP Delegated Design:** Portland Mechanical Contractors Inc.**Electrical Delegated Design:** Portland Electric Group**Low Voltage Delegated Design:** Network Technologies, Inc.**Fire Sprinkler Delegated Design:** Basic Fire Protection Inc.**Façade Precast Panels:** Niradia Enterprises Inc.**Completed:** 2009**Size:** 256 guestrooms**Construction Cost:** \$39,000,000

structural assessment, energy analyses, coordination between contractors, and building scheduling. This project provides a good example of remodeling of a commercial structure and the use of BIM to address LEED certification. The challenges, design strategies, and outcomes will be discussed in the following sections.

## 9.2.2 Project Goals

### *Urban Impact*

Located in the core of the business district adjacent to the public transit mall, the hotel links the traveler to the transit to the airport and the rest of the city, revitalizing the area surrounding the building and adding vitality to a previously moribund street corner.

### *Structure Recycling*

Recognizing the value of the embodied energy within the existing structure, and after comparing the cost involved in renovation versus demolition options, the design team opted for a renovation, rather than building an entirely new structure. The building was seen as frozen capital asking for new investment

to become productive. The “building recycling” approach also minimized the disruption of the construction on the adjacent businesses, reduced the construction time, and relieved disruption of local traffic.

### ***Sustainable Design***

The owner and the design team wanted to demonstrate that it was possible to deliver a high-performance green building for the hospitality industry. This had to be accomplished while fulfilling brand standards and providing for guest comfort.

### ***Resource Efficiency***

Hotels are 24-hour resource-hungry buildings. The design efforts were focused on achieving operational efficiencies in energy and water use. Materials choices were made with a focus on achieving indoor air quality. Goals included avoiding contaminant material emissions in the areas with high guest occupancy, and balancing HVAC systems to provide fresh air in guest areas.

Another target was to maximize the use of natural light to reduce energy consumption. This was achieved by a careful coordination between façade and interiors layout. The owner and architects desired to obtain a high-level LEED certification by combining the targets described above.

## **9.2.3 Design Approach**

### ***The Challenges***

The main challenges were to replace the entire façade, add three floors above the existing thirteen-story structure, redesign and replace the building skin (Figure 9–2–3), completely renovate the internal structure, and install brand-new mechanical systems. It was also necessary to demolish an adjacent three-story structure and replace it with a new four-story back-support structure for the hotel, and tie both structures together to function as one building.

### ***Façade Design***

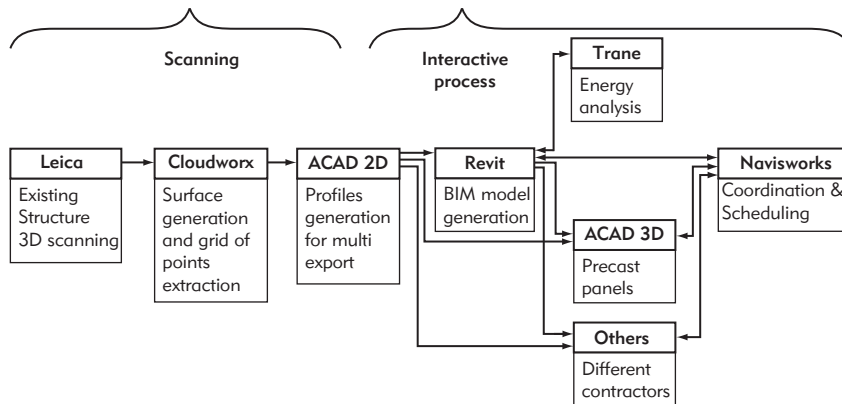
The façade design has a low window-to-wall ratio while balancing the need for day-lighting within the room. This balance was based on the decision of placing the window up near to the room ceiling maximizing the incoming daylight for a standard size window. Additionally, the new façade included high-performance glazing and better insulation on the opaque surfaces.

### ***Systems***

The HVAC equipment and water heater systems for the 256-guestroom hotel were selected along with an additional heat recovery system. The combination



**FIGURE 9-2-3** Sequence of building process. (See color insert for full color figure.)



**FIGURE 9-2-4** General design workflow.

of these systems resulted in a 30 percent energy use reduction as compared to the ASHRAE baseline.

### **Design Workflow**

The general design workflow (Figure 9-2-4) involved two main phases: the scanning process to provide an accurate and reliable description of the existing structure, and the interactive process between the different BIM models derived from this common source of information. These phases are addressed in the next two sections. Additionally, the project management was aided by Newforma, a project/document management tool, keeping track of the project documents and files along the design process.

### **9.2.4 Scanning the Existing Structure**

The original building construction was of extremely poor quality. The building never received a certificate of occupancy, and remained empty for almost two decades after it was built. In order to understand the existing conditions, a full

laser scan of the structure was performed. Hoffman Construction Company, the general contractor, was in charge of the scanning process. It wasn't in the original bid, but the general contractor negotiated with the owner to provide this service later in the project, considering the complexity of the existing structure. Hoffman is experienced in laser scanning and provided this service themselves. They used a Leica Scan station time-on-fly scanner for the work (Jacobs 2010). Point cloud data was registered and integrated using Cloudworx software to generate a set of surfaces describing the geometry of the existing building.

The high-density point clouds allowed integration of the new design with existing conditions

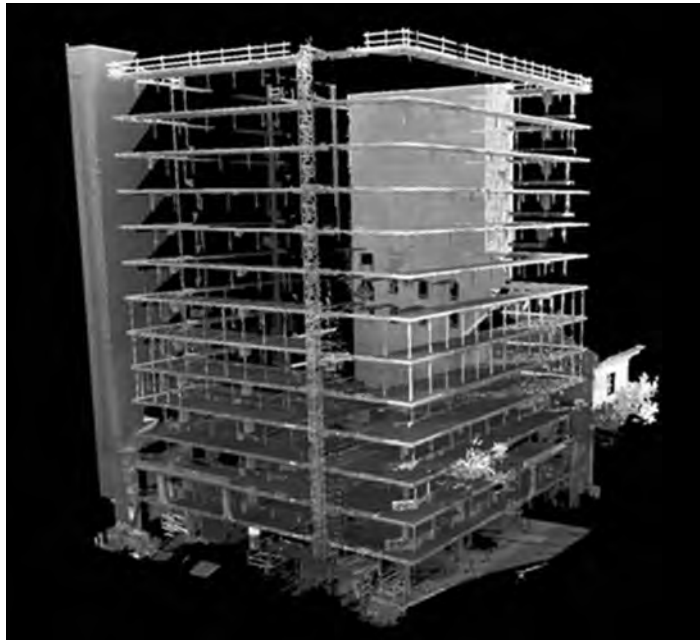
### ***The Scanning Process***

Four scans per floor (for 14 floors) were performed for the floor flatness phase. Two scans per elevation were performed for all four elevations for the façade phase. The data from these scans were then integrated into a massive point cloud describing the existing conditions (Figure 9-2-5). The information was loaded into Cloudworx in order to better understand the existing geometry of the irregular slab edges, column grid, and core walls. Cloudworx can achieve good levels of interoperability exporting to AutoCAD (ADC 2010). Hoffman Construction Company decided to split the original point cloud of the building

**FIGURE 9-2-5**

Integrated 3D scan.

Image credit: Hoffman Construction Company.



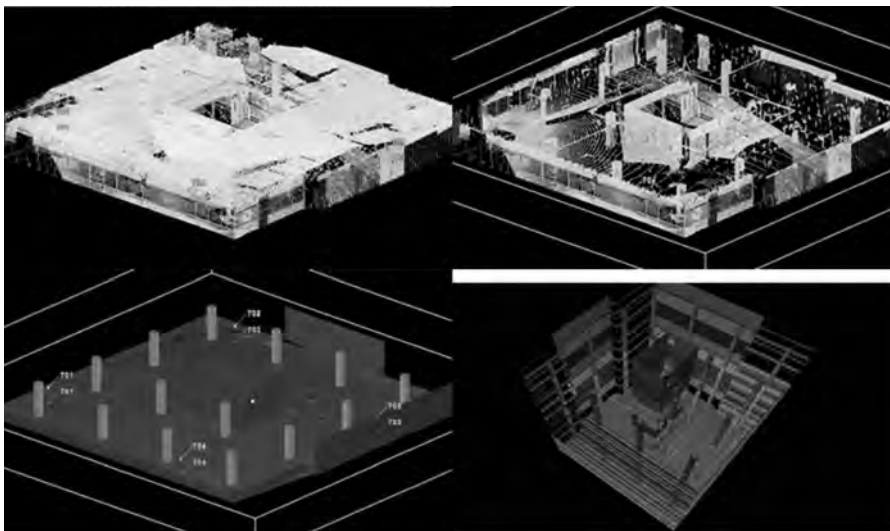
by floor to simplify the amount of data to be manipulated. For every floor, surfaces of the slabs, walls, and columns were generated. The purpose of this was to visualize and clean up the original set of points and identify the key geometry features.

### Surface Generation

Slices through the point cloud data facilitated the creation of the 2D drawings that would provide a high-resolution description of any given cross-section. Those sections were able to be plotted to get draft plans and sections.

Leica Cloudworx allows users to define planes across the point cloud, selecting a plane using external points as a reference to simulate 2D representations. The 2D slice can also be moved from its original position for visualization of perspective images. Although Cloudworx only allows one section at a time, its movability feature compensates for this limitation. The dynamic 2D section of the point cloud drove the manual modeling process. They traced lines or poly-lines on top of the slices and took advantage of the additional zooming and snapping features (Cloudworx 2002). The resulting surfaces are generated from the manually traced lines or poly-lines. The entire process provided accurate deliverables and reduced the effort of the manual remodeling process.

Surface modeling was done floor-by-floor because the scanned point cloud does not have any structure for representing objects. A large number of details are registered through the scan, and they needed manual review to be identified. As can be noticed in the bottom of Figure 9-2-6, the surrounding trees



**FIGURE 9-2-6**

The floor-by-floor modeling process. Upper left: full floor point cloud; upper right: ceiling retired for visualization; lower left: surface modeling; lower right: floors database (See color insert for full color figure.)

Image credit: Hoffman Construction Company.

have been captured as well. After this structuring and cleanup, the new version of the floor surfaces are stored together in the same file to keep consistency in terms of relative positioning.

Although we can recognize elements in the point cloud, it is not possible to perform accurate automatic identification with current technology. Hence, this scanning phase is extremely labor-intensive and leaves room for human error, misunderstanding, or wrong interpretation of the scanned data. However, these tools and their related methods provide a reasonably accurate description of a complex structure.

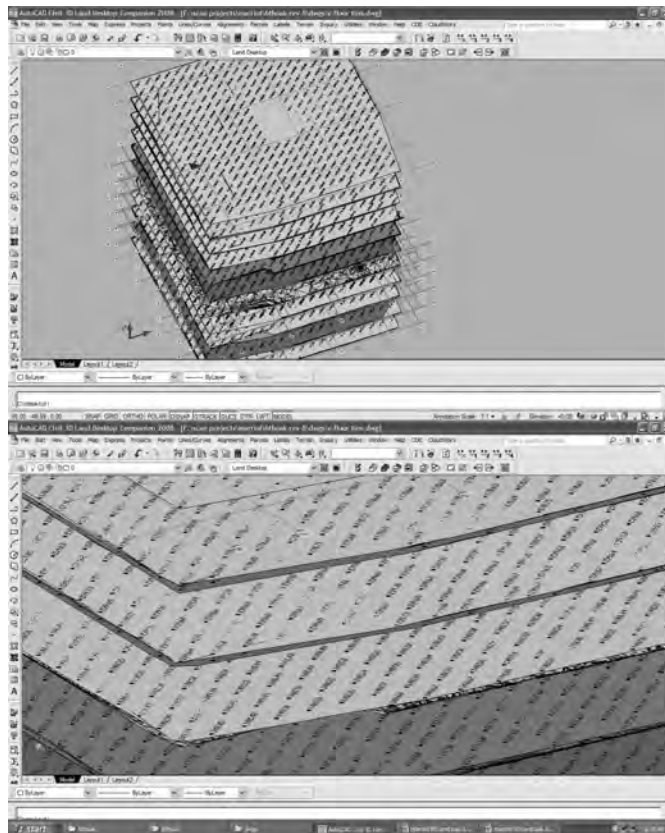
### ***Point Grid Correction***

Having modeled the surfaces describing slabs, walls, ceiling, columns, and other important building features, the entire set of scanned floors were integrated in the same file to track their consistency and look for errors and potential dimensional floor-to-floor variations (Figure 9–2–7).

**FIGURE 9–2–7**

Regular point grid generation of slab elevations.

Image credit: Hoffman Construction Company.



Based on the corrected surface geometry, a new grid of points was generated at regular intervals. This exhaustive information analysis uncovered several places with up to 3-inch column grid offset from one floor to the next, and sags in the slab edges up to 4 inches. Dale Stenning, Operations Manager for Hoffman, pointed out at the 2009 Leica Geosystems HDS Worldwide User Conference, “Had we not noticed the column offset early, we would have had a huge problem later on when it was finally discovered.” The resulting irregular slab geometry was crucial to define the façade edges for the precast panels. Discovering these dimensional variations during the panel installation could dramatically affect the installation process as well as the performance of the seals.

### 9.2.5 Façade Precast Panels

In the second phase, several aspect models were developed by different sub-contractors for different purposes, all of them based on the building structure description developed by the scanning process. A Revit BIM model was built to support design development. This model was the main source of information for cost estimation and decision-making regarding material specification, energy, and water consumption. The entire MEP system was also defined in Revit. Finally, for project coordination and planning, the whole set of models were integrated into Navisworks (Navisworks 2010). From that point on, an iterative, interactive process between the different aspect models was driven by the Navisworks model. It also allowed reviewing and continuously refining the main Revit 3D model.

#### ***3D Solid Model from 2D Profiles***

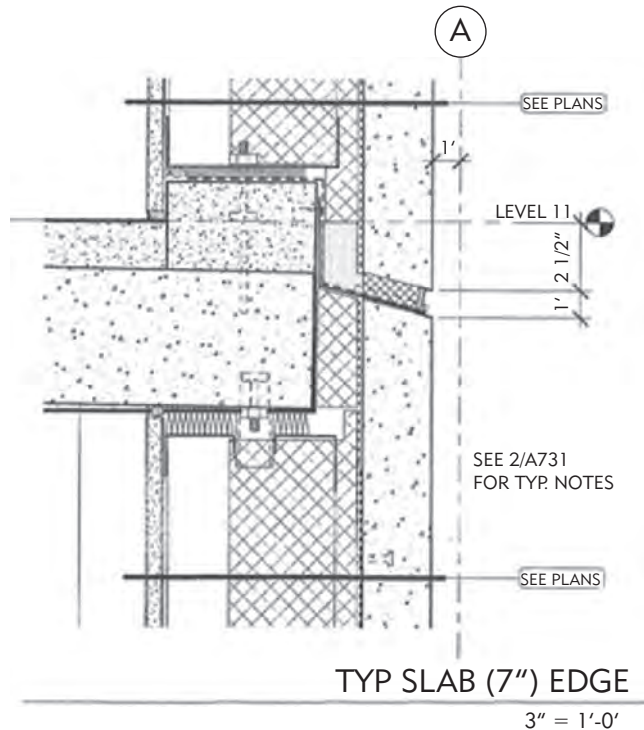
From the corrected grid of points, regular lines and poly-lines were manually traced to accurately describe the façade edges. This new set of AutoCAD 2D drawings was passed to Niradia Enterprises Inc., the façade panel fabricator, to build their own solid model of the existing structure. They used AutoCAD 2008 with the Pro-Steel add-on to manage the steel stud layout and produce bills of material.

The scanning of each floor provided valuable structural data to the design team. Because of the deficiencies in the existing structure, the skin of the building could not add significant weight beyond existing structural loads. In addition, the proposed design could not subtract from the existing floor edge due to the nature of the existing post-tensioned slab. These restrictions required the design team to find a solution within the existing structural constraints.

The original panel designs were based on uniform edges, but the high-definition survey revealed very irregular geometry along the slab edges. Fortunately, the point cloud grid refinement revealed these irregularities well

**FIGURE 9-2-8**

Slab edge detail showing sloping slab, new topping to level the slabs and the curb to carry the wall panels.



before the actual fabrication process. The slabs received a new topping applied to remove the elevation changes, as shown in Figure 9-2-8.

In Hoffman's words, the use of the laser scanning added an additional "reality layer" for the BIM model, since reality usually diverges dramatically from virtual models. Although this procedure provides accurate results, it is extremely labor-intensive, since 2D profiles and 3D solid models are basically created manually.

### ***Precast Façade Panels Installation***

The precast panels were fabricated in Canada by Niradia Enterprises ([www.niradia.com](http://www.niradia.com)). Niradia was a subcontractor to Performance Contracting, Inc. who was subcontracted by Hoffman Construction. The precast panel system was chosen because of the limited load capacity of the existing structure and its relatively light weight. The main construction challenge with the panels was accommodating the existing building slabs, which were out of plane from each other horizontally, while keeping a consistent flat plane on the perimeter of the building. Curb/slab edges were poured at the perimeter of the building to allow the precast to bear consistently from floor to floor (Figure 9-2-9).





**FIGURE 9-2-9**  
Precast panel installation  
process.

Because of errors in the curb formwork on the interior side, they had to trim out some of the poured curbs when they protruded into the space inside.

The approximately 300 resulting panels included built-in metal studs for the interior of the outside wall. The panels consisted of three basic patterns: a window opening with typical panels on either side, a window opening with a typical panel to the right and a grooved panel to the left, and a window opening with a typical panel to the left with a grooved panel to the right. These were staggered across the façade and their sizes were typical, with some exceptions. Level 2 is where the panels start and there is a special detail at the base and also wherever the panels met existing conditions. Level 12 panels needed to be taller as there was a greater floor-to-floor height between it and the floor above. Parapet panels led to taller panels as well. The corner conditions were different as well and had special panels and detailing associated with them. Strong horizontal floor lines express the existing structure, while a vertical pattern of alternating windows allow expression of the cellular nature of hotel rooms. The finish of the repetitive panel system was created using sandblasting and color. The result of this process was a fast and smooth installation (Figure 9-2-9).

### 9.2.6 From Revit to LEED Certification

#### ***LEED Certification***

The Leadership in Energy and Environmental Design program, or LEED, developed by the U.S. Green Building Council, involves several aspects: energy and water consumption, carbon emissions, indoor environmental quality, and

environmental impact. The LEED program defines a framework to implement more sustainable design solutions, construction processes, and maintenance through the building lifecycle. The original design decision regarding the reuse of the existing structure was a significant contribution to minimize environmental impact and the use of resources along the construction process. The challenge for SERA Architects was to balance the traditional high consumption standards of the hotel industry with the green LEED standards. The Revit model built from the scan was the main source of information to support the desired LEED certification, in terms of water savings and internal air quality. In the case of the energy savings, the Revit (Figure 9–2–2) model was used as the basis of the energy model developed in Trane Trace™ (Trane 2008).

### ***Water Savings***

The property achieves a 26 percent reduction in water consumption via the use of dual-flush toilets and low-flow faucet aerators in all guestrooms, along with low-flow back-of-house fixtures. This is a significant reduction for a traditionally high water demand building.

### ***Air Quality***

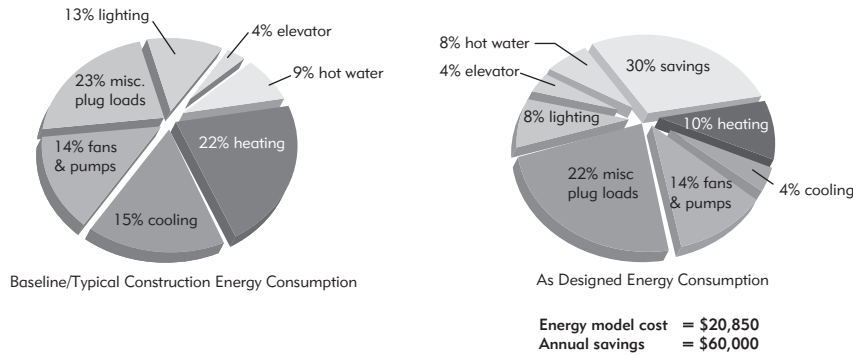
Material choices were made with a focus on recycled content, regional materials, and the health of the building occupant. Guestroom wall coverings are non-PVC, casework has no added urea-formaldehyde, providing a healthier environment where guests reside.

### ***Energy Model***

#### **The energy model included:**

- High Performance Glazing
- Increased Building Insulation
- High-Efficiency Lighting
- High-Efficiency HVAC Equipment
- High-Efficiency Water Heater
- Heat Recovery System

The energy modeling work was based on TraneTrace™ to input building design information from the CAD model. Trace has no effective and reliable input from Revit, so the consultants build the energy data input by hand. The additional cost for the energy analysis was \$20,850, which looks attractive compared to the savings, since it is expected that in ten years the property will



**FIGURE 9-2-10**  
Energy model analysis results.

save over \$600,000 just in utility costs. Another benefit from the energy modeling effort is that it required the entire design and building coordination team to work together, as the energy model requires information from the entire set of subcontractors. Throughout the process of energy modeling, they had the opportunity to find conflicts and resolve them early in the design process instead of later in the field.

The energy modeling efforts provided 30 percent savings when compared to a typical building's energy consumption (Figure 9-2-10). Although this exercise proved its ability to provide valuable results (i.e., LEED certification), such a process did not facilitate feedback between design and analysis, and in reality hinders interaction, given that every design modification means a new cycle of analysis and manual input for energy analysis is typically required.

### **LEED Analysis Results**

The Courtyard was the first Marriott property to receive LEED Gold certification. It provided a primary example of how a mid-scale hotel can achieve a high level of performance, without bypassing industry operating practices and standards.

Despite the fact that sustainable development requires extra investment (Figure 9-2-11, Soft and Hard Cost Premium), the Oregon state incentives compensated for such initial costs and after ten years the property will save over \$675,000 in utility costs. The annual energy savings and reduction in water consumption are estimated to be 30 percent and 26 percent, respectively from the first year of operation. The estimates of emission from materials for interior surfaces based on the Revit model assure a healthy indoor environment for guests and employees. The additional cost to get the LEED Gold certification represented only the 1.2 percent of the total construction cost.

**FIGURE 9-2-11**  
Extra investments to achieve  
LEED standards.

Courtyard by Marriott Portland City Center, Portland, OR - LEED Gold Target Opening Spring 2009  
Values specific to the Pacific NW

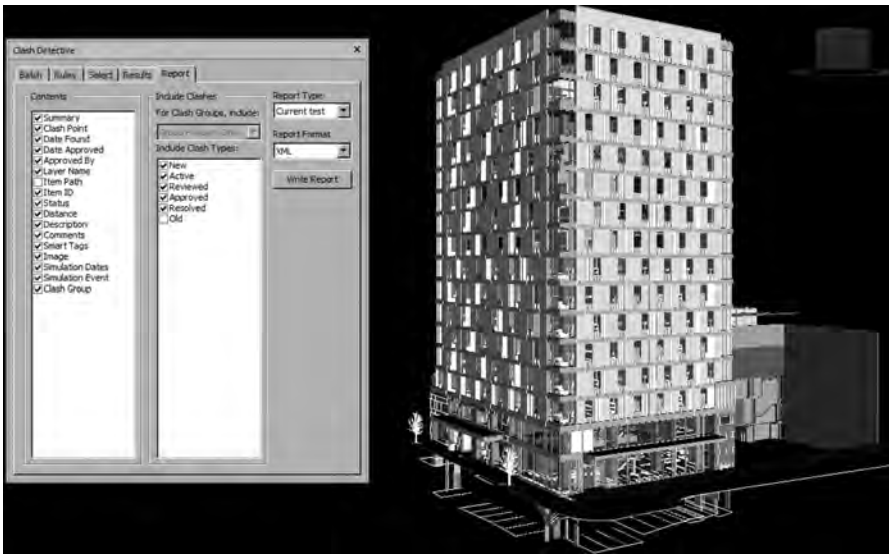
<b>Soft Costs</b>		<b>Incentives</b>	
Incentive Registration	\$ 1,822	State Grant Incentives	\$ 280,000
LEED Registration Fee	\$ 6,820	State Tax Credit Incentives (pass through)	\$ 153,942
Commissioning	\$ 90,000	Reduced City Development Charges	\$ 124,176
Energy model	\$ 23,850	<b>Total Incentives</b>	<b>\$ 558,118</b>
LEED credit calculation	\$ 43,000		
LEED process management	\$ 50,400	<b>Costs Premium After Incentives</b>	<b>\$ 88,185</b>
<b>Total Soft Costs</b>	<b>\$ 215,892</b>		
<b>Hard Cost Premiums</b> above typical to achieve sustainability goals		<b>Utility Cost Pay Backs &amp; Operating Expenses</b>	
Sustainable Sites	\$ 2,400	Energy Cost Savings per year	\$ 58,035
Water Efficiency	\$ 16,240	Water & Sewage Cost Savings per year	\$ 5,880
Energy & Atmosphere	\$ 188,800	Additional Ops Costs (one time)	\$ 2,000
Materials & Resources	\$ 0	Green Power & cost per year (2yrs)	\$ 8,360
Indoor Environmental Quality	\$ 46,610	Fuel Efficient Vehicle cost per year (2yrs)	\$ 2,400
Innovation & Design	\$ 0	Operations Cost Savings year 1	\$ 52,355
<b>Total Premiums</b>	<b>\$ 254,050</b>	Operations Cost Savings year 2->	\$ 63,115
		Operations Cost Savings 10 years	\$ 676,331
		(assumes 2% utility cost increase per year)	

**Soft & Hard Cost Premium** 1.2% of cons. **\$ 469,942**

Inflows and Outlays	Development & Construction			Operations									
	Year 1	Year 2	Year 3	Year 1	Year 2	Year 3	Year 4	Year 5	Year 6	Year 7	Year 8	Year 9	Year 10
<b>Cash Inflows</b>													
Utility savings				\$ 63,915	\$ 65,193	\$ 66,497	\$ 67,827	\$ 69,184	\$ 70,567	\$ 71,979	\$ 73,418	\$ 74,887	\$ 76,384
Incentives		\$ 124,176				\$ 433,942							
<b>Cash Outlays</b>													
Green Power			\$ (16,720)										
Green Housekeeping				\$ (2,000)									
Zip Car				\$ (2,400)	\$ (2,400)								
Soft Costs Premium													
Construction Premium	\$ (215,892)												
Equipment Premium		\$ (143,114)											
		\$ (110,927)											
Buildings Depreciation Tax Savings				1,503	1,503	1,503	1,503	1,503	1,503	1,503	1,503	1,503	1,503
Equipment Depreciation Tax Savings				3,328	6,656	6,656	6,656	6,656	6,656	6,656	6,656	3,328	
	\$ (215,892)	\$ (129,865)	\$ (16,720)	\$ 64,346	\$ 504,894	\$ 74,655	\$ 75,985	\$ 77,342	\$ 78,726	\$ 80,137	\$ 78,249	\$ 76,389	\$ 77,887

**FIGURE 9-2-12** Costs for LEED/Sustainability ROI analysis.

The design team also produced a LEED Cost/Benefit Analysis for the project, geared specifically for the hospitality industry (SERA 2010) (Figure 9-2-12). Depreciation Tax Savings assumes straight line depreciation, 42 percent tax rate, 40-year building life, and 7-year equipment life. The project team claims a 26 percent return on investment for money spent within the project on green initiatives. (Utility cost escalation assumed at 2 percent.) The study has been well received within the industry, and the information it provides is a resource for further pursuit of LEED ratings in the hospitality industry.



**FIGURE 9-2-13**  
Navisworks' model for  
contractors' coordination  
and scheduling.

## 9.2.7 Subcontractors' Coordination

### *Team coordination*

The project was developed in a narrow timeframe: the design took approximately 7 months and the construction took approximately 19 months. It was decided that in order to streamline the coordination processes and reduce the amount of effort, the team project would use a centralized document control system. After investigating several different options, the team decided to go with Newforma (Newforma 2010). This allowed them to file and access all of the generated files (documents, models, presentations, and the like) from one place. This simplified management, as they could generate and receive transmittals, official document sets, FTP-type large-file transfers, and so forth from one central application.

A Navisworks model was the main interface between the different subcontractors. This was the first time that SERA and the project consultants jointly employed Navisworks. The Navisworks model (Figure 9-2-13) enabled the integration of the different, separately detailed Revit aspect models derived from the original scanned structure geometry, facilitating early conflict and clash detection. The team found potential clashes between mechanical systems and the existing structure in the ballroom which would have been very expensive to solve during the construction phase. This Navisworks feature enabled the team to be proactive during the design phase instead of reactive during the construction. The SERA team points out that “. . . you get what you want during the design phase, rather than living with what you don't want later.” Consequently,

the Revit model used by the design team was continuously refined throughout the process. The integrated Navisworks model was also used for 4D scheduling to facilitate the construction process as well as the offsite prefabrication of components. The Navisworks model enabled the design team to be more flexible working with the wide range of consultants involved in the project for mechanical systems, energy, low voltage, plumbing, HVAC, and so forth. The simulation of the construction process allowed a deeper understanding of the complexity of the process, and better predictability of potential conflicts during construction, helping to reduce delays and sequencing problems. No automated link existed between Navisworks and Newforma.

### **9.2.8 Lesson Learned**

#### ***Scanning***

How does one recognize objects when the point cloud from the 3D scan is processed? Despite the fact that the current translation is highly precise and the existing tools and their related methods provide descriptions to be derived of complex structures, it is still extremely labor-intensive and leaves room for human error, misunderstanding, or wrong interpretation of the source information. Although elements can be visually recognized by the user, the current technology still cannot perform such recognition automatically. Developing the inference process behind vertices (points), edges (lines), and surfaces (planes) into BIM objects is a research area which could facilitate building renovation by moving the scanning process toward automation.

#### ***Design and Evaluation Interaction***

How does one improve the information exchange between design and evaluation? The current process hinders the interactive relationship between these processes. While the design occurs in the Revit environment, analyses are performed in Trane in the case of energy consumption or in Navisworks in the case of clash detection. This sort of parallelism and information duplication demands a sizable number of export/import operations, which were manual in the case of Trane Trace, increasing the coordination risks, and making the process slower, reducing the feedback from different project aspects during the design process.

#### ***Aspect Models Synchronization***

How does one synchronize the entire family of BIM models from different domains? From the same 3D scan, consistent models were produced for different purposes. However, the same source information later diverges. Achieving parallel design development filtering that can be simultaneously viewed by the

rest of the design team through the Newforma document administration system greatly improved communication, synchronization with the building model, and helped in supporting real-time design feedback.

## Acknowledgments

This case study was originally written by Marcelo Bernal, Ph.D. Student in Design Computing from College of Architecture, Georgia Institute of Technology, for a class taught by Chuck Eastman. It was developed with the collaboration of Crawford Smith, BIM Specialist, and Cathy Ballensky, Project Architect, from SERA Architects; Dale Stenning, Hoffman Construction Company Operations Manager; and Ash Botros, Manager of Dev. & Tech. from Niradia Group. Credit for the images, except where notes otherwise: SERA Architects.

---

### 9.3 SUTTER MEDICAL CENTER, CASTRO VALLEY *BIM within an Innovative IPD Contract that Specified Project Goals, Lean Methods, and Ensured Goal Alignment of Team Members*

#### 9.3.0 Introduction

This case study describes a hospital being built by Sutter Health in Castro Valley, California that will replace the existing Eden Medical Center, an older facility that required state-mandated seismic replacement. The project team is organized in an integrated project delivery form (IPD) that is growing in popularity because it facilitates early and continuous collaboration during design and construction. In addition, the contract documents (Integrated Form of Agreement—IFOA) specify that the 11 main team members share in the project contingency funds and hence jointly control their opportunity for gain or loss. This, together with use of BIM and lean project management techniques make this a path-breaking project that deserves close observation to determine whether this management approach should be a model for the future, and if so, under what conditions. This case study was written early in the construction process (pilings, foundation work, 30 percent complete on steel erection) and detailed design had not yet been completed. The scheduling of the design effort was based on requirements for meeting OSHPD (Office of Statewide Health Planning and Development) phased requirements. Meeting these milestones was a primary owner goal.

This allowed earlier than normal granting of a permit to begin construction and greater overlapping of design and construction. It required close collaboration with OSHPD. An equally important goal was to reduce the risk of exceeding the owner's budget for this project. To reduce risk, the team adopted a number of planning, collaboration, and procurement strategies that are described in this case study. While it is too early to know if the unique features of this project will result in exceptional results, the indications thus far are very promising. This conclusion is based on a survey of all team leaders, successful target cost analysis, improved design features, and a faster issuance of a construction permit by OSHPD and, hence, an earlier start of construction by about six months—as compared to a traditional design-bid-build project of this size.

### 9.3.1 Project Description and Owner Goals

#### *Project Description*

Sutter Medical Center, Castro Valley (SMCCV) will replace the existing 55-year-old Eden Medical Center, a full-service, 173-bed, not-for-profit medical center with campuses in Castro Valley, serving the health care needs of residents of Alameda County and surrounding communities. The SMCCV project is undertaken in accordance with the Alquist Hospital Facilities' Seismic

**FIGURE 9-3-1**

A computer-generated image of the new hospital and its campus setting.

Image provided courtesy of Sutter Health and Devenney Group, Ltd., Architects.





**Table 9-3-1** Project Milestones Including Submittals to OSHPD and Construction Deadlines

---

Demolish approximately 20,000 square feet of existing medical office buildings
Demolish an existing 42-unit apartment complex (Pine Cone Apartments)
Relocate an existing helistop (approximately 150 feet) within the Eden Medical Center
Construct an approximately 230,000-square-foot, state-of-the-art acute care hospital containing approximately 130 licensed beds in single-bed rooms and seven stories
Demolish the existing approximately 29,000-square-foot Laurel Grove Rehabilitation Hospital containing approximately 27 licensed beds
Demolish the existing Eden Medical Center
Develop/redevelop new surface parking, campus circulation, and other site improvements (landscaping, stormwater drainage improvements, "green" sound walls/"living walls," and so forth)

---

Safety Act of 1983 and California State Senate Bill 1953 which requires the replacement or seismic retrofit of existing acute care facilities prior to the compliance date of January 1, 2013. In order to be ready with the new hospital by that date Sutter Health had to find a way to get a hospital planned, priced, designed, permitted, built, licensed, and open in five years and three months. In parallel, permission to build had to be sought from the county. This time pressure required radical approaches to the contract and the design and construction processes as described in this case study.

The SMCCV project site is 18.97 acres (generally the existing Eden Medical Center Campus). The new hospital will ensure that medical services will continue to be provided by a licensed acute care hospital on the existing Eden Medical Center Campus without disruption during construction and thereafter. The following sequence of activities will take place over a continuous period of approximately five years, starting in mid-2009 with planned completion by the end of 2013.

### **Owner Goals**

The specific goals of Sutter Health on this project are shown in Table 9-3-2. These are stated in Exhibit 1 of the contract documents for this project.

These are very ambitious goals, particularly those dealing with the rapid pace of delivery, a strictly limited budget, and the extensive use of collaborative design and construction approaches that leveraged the use of BIM for lean project delivery. This case study will analyze how many of these goals were implemented and what issues needed to be addressed. For all of the project participants, this project represented a real learning experience that was facilitated by strong support from the owner.

**Table 9–3–2** Specific Owner Goals for SMCCV Project**Introduction**

A project is not considered successful by the owner unless it meets the owner's goals. Often these goals are unstated, not clear, vary with time, or vary with the individual. On this project this will not be the case. The goals will be explicitly stated in this document.

**GOAL 1: Structural Design Completion:** The first incremental package will be submitted to OSHPD for review no later than December 31, 2008.

**GOAL 2: Project Cost:** Total cost of the project shall not exceed \$320,000,000 (this includes demolition of old hospital).

**GOAL 3: Project Completion: The replacement hospital shall open, fully complete and ready for business, no later than January 1, 2013.**

GOAL 4: Healthcare Delivery Innovation

Cellular concept of healthcare design to be utilized

Control center concept to be utilized

Electronic health record system implemented

**GOAL 5: Environmental Stewardship**

Meet any one of the following:

- the standards for certification at the SILVER level per LEED for Healthcare (draft version)
- the standards for certification at the SILVER level per LEED NC v2.2
- achieve CERTIFIED level per LEED for Healthcare (final)
- achieve CERTIFIED level per LEED NC v3.0

**GOAL 6: Design & Construction Delivery Transformation: The building will significantly transform the delivery model for the design and construction of complex healthcare facilities**

- higher percentage of total budget under IFOA
- new incentive structure (gainshare/painshare)
- new method of defining project goals
- new methodology for the design process
- new methodology for planning and tracking commitments
- new methodology of active engagement with the state regulatory agency
- far more extensive usage of BIM and virtual design and construction
- use of target value design
- sophisticated commissioning & operations and maintenance handover
- energy modeling

### 9.3.2 General Description of Project Management Techniques

#### ***Contract Method: Sutter Health's Integrated Form of Agreement (IFOA)***<sup>1</sup>

The project uses for the first time an 11-party IFOA where the owner, the architect, the general contractor, key design consultants, key trade partners, and the

<sup>1</sup>The contract for this project was written by Will Lichtig, a member of the Construction Practice Group at McDonough, Holland & Allen PC ([www.mhalaw.com/mha/attorneys/lichtig.htm](http://www.mhalaw.com/mha/attorneys/lichtig.htm)).

Lean/VDC consultant are all cosignatories of the agreement and members of the IPD team. In previous versions of the IFOA the owner, architect, and general contractor signed a three-party agreement to form the core team. The IFOA on this project included all significant project participants and requires the team to work collaboratively, use BIM technologies, and to implement lean practices that drive waste from the project delivery system. The IFOA signatories share risk or savings if the project is delivered above or below its target cost.

Sutter Health has been experimenting with integrated project teams and lean design and construction practices over the past five years. They have had considerable success in using these techniques on their recent projects, one of which was described in the first edition of the *BIM Handbook* (see Section 9.3.3 Camino Medical Group Mountain View medical office building complex). This project represents an extension and formalization of the lessons learned on prior projects. There is an excellent description of the IPD contract and how it supported the goals of this project in a paper presented at the 48th Annual Meeting of Invited Attorneys.<sup>2</sup>

There is a good working definition of Integrated Project Delivery from the Lean Construction Institute<sup>3</sup>:

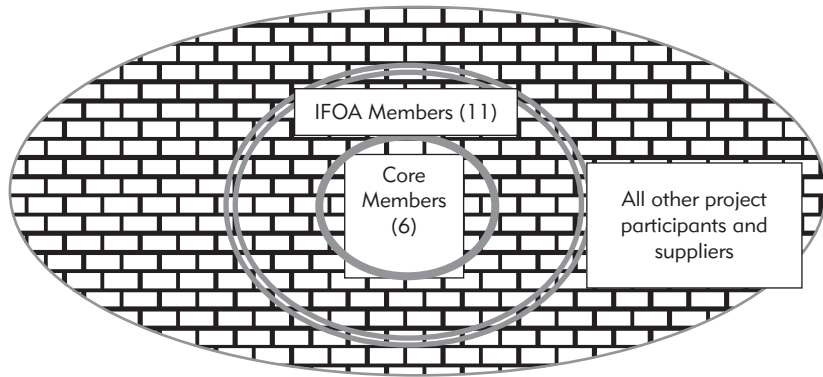
Integrated Project Delivery™ (IPD) is a delivery system that seeks to align interests, objectives, and practices, even in a single business, through a team-based approach. The primary team members would include the architect, key technical consultants as well as a general contractor and key subcontractors. It creates an organization able to apply the principles and practices of the Lean Project Delivery System. For more information see [www.leanconstruction.org/lcj/V2\\_N1/LCJ\\_05\\_003.pdf](http://www.leanconstruction.org/lcj/V2_N1/LCJ_05_003.pdf).

IPD principles can be applied to a variety of contractual arrangements and IPD teams will usually include members well beyond the basic triad of owner, designer, and contractor. At a minimum, though, an integrated project includes tight collaboration between the owner, architect/engineers, and builders ultimately responsible for construction of the project, from early design through project completion.

---

<sup>2</sup>Integrated Project Delivery: Different Outcomes, Different Rules by Robert Mauck, AIA, P.E., William A. Lichtig, Esquire, Digby R. Christian, and Joel Darrington, Esquire ([www.mhalaw.com/mha/newsroom/articles/Proceedings09\(Lichtig\).pdf](http://www.mhalaw.com/mha/newsroom/articles/Proceedings09(Lichtig).pdf))

<sup>3</sup><http://leanconstruction.org/>.



**FIGURE 9-3-2** An integrated project team was developed for the project that allowed all IPD participants to participate as equals in the design and construction process. This improved the collaboration of the team, reduced the time needed for permit submittal and acceptance, allowed overlap of design and construction, and enhanced lean processes as described in the case study.

**Table 9-3-3** Eleven Members of the IPD team

Function	Firm
Owner	Sutter Health*
General Contractor and self-performer of Concrete, Framing, Drywall	DPR Inc.*
Architect	Devenney Group*
Mechanical & Plumbing Design	Capital Engineering*
Electrical Design	The Engineering Enterprise
Structural Design	TMAD/Taylor and Gaines
Fire Protection—Design-Build	Transbay Fire Protection
Mechanical design assist and contractor	Superior Air Handling
Process and Technology managers	Ghafari & Associates
Plumbing design assist and contractor	J.W. McClenahan*
Electrical design assist and contractor	Morrow-Meadows

\*Members of Core Group which also included a representative from the Eden Medical Center

While a typical design-bid-build project would prevent the trade contractors from doing detail design until after the project had been bid, the integrated project organization shown in Figure 9-3-2 and listed in Table 9-3-1 allowed the general contractor and trade contractors to participate in the design by adding cost and constructability knowledge to the design as it was developed. This intense collaboration was enhanced by having daily and weekly meetings at a large work area located at the project site called the “big room”

equipped with meeting rooms, white boards, computer, and projector support. This space was used by design team members and trade contractor detailers working with the IPD team members so that trusting relationships could be developed and problems could be identified early and resolved quickly. This collaborative process is described in greater detail below.

A primary goal of the owner was to reduce overall project duration so that the new hospital would become operational by January 2013. To achieve this goal, construction permits were needed faster than would normally be possible. In addition, design of foundations and structural steel needed to reflect the requirements of all MEP systems. An intense planning effort was initiated to develop the processes that would be used.

With regard to BIM, each IFOA team member was required to provide their design in 3D format (see Table 9–3–5 for a list of systems used for modeling). Ghafari Associates managed the planning, workflows, and technologies

**Table 9–3–4** Lean Design and Construction Approaches Established by Sutter Health for This Project

Goals of Sutter Health Lean Project Delivery	Lean Approach
Better collaboration to improve constructability, reduce errors in field, save time and cost ,and increase speed of resolution of questions	Trade contractors brought in early to participate in design from the beginning. Use of BIM for all key design, detailing, and fabrication functions
Share in pool of profit to align goals of team with owner which allows them to optimize project, not the pieces. Better collaboration to reduce costs. Design to a target cost, continuously monitor to ensure that target will not be exceeded, both before and during construction	Target value design
Increase relatedness and trust among project participants	Continually review schedule of design tasks to ensure that submittals will be made on time. Biweekly work planning. Daily updating of tasks. Develop (and continually replan) links of tasks required to meet milestone dates. Ensure that only what is needed to meet milestone is included in each task. Use a computer system that provides visibility of tasks and relationships to provide improved visual reporting, transparency, and collaboration.
Better collaboration using an accurate and complete 3D model integrated from the many models used by team members. Reduce changes and problems that would slow construction and increase costs	Build virtually in 3D before constructing

**Table 9-3-5** Software Used on the SMCCV Project

Company	Role on the Project	Scope	Model Creation Systems	Primary Role of the Software	Exports to	Imports from
<b>SAHCO</b>	Design Assist Mechanical Subcontractor	HVAC Model Pneumatic Tube Model	AutoCAD CAD Duct	Produce fabrication-level models of HVAC and Pneumatic Tube systems	Autodesk Navisworks Manage	CAD Duct Design Line AutoCAD
<b>JW McClenanhan</b>	Design Assist Plumbing Trade Contractor	Plumbing Model	AutoCAD CAD MEP	Fabrication-level models of plumbing systems	Autodesk Navisworks Manage	CAD Duct Design Line AutoCAD
<b>Transbay Fire Protection</b>	Design-Build Fire Protection Subcontractor	Fire Protection Model	AutoSPRINK	Fabrication-level models of Fire Protection system	Autodesk Navisworks Manage	AutoCAD
<b>Morrow Meadows</b>	Design Assist Electrical Subcontractor	Electrical Model	AutoCAD CAD MEP	Fabrication-level model of Electrical and Cable tray	Autodesk Navisworks Manage	AutoCAD
<b>Capital Engineering Consultants See problem #1</b>	Mechanical and Plumbing Engineers	Design Model for Mechanical and Plumbing	CAD Duct Design Line AutoCAD	Design model for Mechanical and Plumbing systems	Autodesk Navisworks Manage CAD Duct	AutoCAD
<b>The Engineering Enterprise</b>	Electrical Engineers	Electrical Design Model	AutoCAD	Design model for Electrical	Autodesk Navisworks Manage	AutoCAD
<b>DPR Construction, Inc. See problem #2</b>	General Contractor	Models of drywall, miscellaneous supports and steel; Developing quantities and cost estimates	Revit, AutoCAD Architecture, Timberline Estimating, Innovaya Visual Estimating, StrucSoft Metal Wood Framing, Autodesk Design Review	Models of drywall, misc. supports and steel; Developing quantities and cost estimates from model	Autodesk Navisworks Manage, Metal Wood Framing, Autodesk Design Review, Innovaya Visual Estimating	AutoCAD Revit
<b>TTG See problem #3</b>	Structural Engineer	Structural design model	ETABS Revit	Analysis and Design Model for Structure	Autodesk Navisworks Manage	ETABS
<b>ISAT</b>	Seismic Support Contractor	Seismic Restraint	AutoCAD	Seismic support models	Autodesk Navisworks Manage	
<b>Sparling</b>		Low-Voltage electrical	AutoCAD		Autodesk Navisworks Manage	

Company	Role on the Project	Scope	Model Creation Systems	Primary Role of the Software	Exports to	Imports from
<b>ISEC</b>	Casework Contractor	Casework	Revit	Casework models	Autodesk Navisworks Manage	AutoCAD
<b>Devenney Group See problem #4</b>	Architect	Architectural model	Revit	Architectural Design models	Autodesk Navisworks Manage, Metal Wood Framer, Innovaya Visual Estimating	AutoCAD
<b>Multiple Parties</b>	N/A	Coordination of various models for Clash Detection and comparing the Design changes	Autodesk Design Review, Autodesk Navisworks Manage	Clash detection and coordination	Autodesk Navisworks Manage	All modeling applications used by various companies
<b>Harris Salinas/ Greg Luth and Associates</b>	Rebar trade contractor and rebar detailers	Rebar model	Tekla Structures 14	Fabrication-level Rebar models	Autodesk Navisworks Manage	Revit
<b>Herrick Steel See problem #5</b>	Structural Steel Subcontractor	Structural Steel Fabrication Model	Tekla Structures	Fabrication-level structural steel models	Autodesk Navisworks Manage	Revit
<b>Strategic Project Solutions</b>	Software Supplier for Scheduling and Supply Chain	Planning System Material Mgt. System	Strategic Project Solutions Production Manager (not a model creation system)	Last Planner System as well as system to manage the Process mapping process	Not linked to any other system	Not linked to any other system
<b>Ghafari</b>	Process Consultant	BIM Coordination and Process mapping, Consultant	Bentley ProjectWise Collaboration System (not a model creation system)	Model collaboration system in a distributed federated architecture		All modeling applications used by companies

required to maintain the various models and associated documentation on its collaborative servers running Bentley ProjectWise. IT staff from the IFOA team members helped implement, configure, and deploy the ProjectWise system in their own local area network (LAN) environments to make everything work. This system provided the distributed team real-time and immediate access to all project information which ensured that everyone was working with the latest information and reduced the errors and rework that could be caused by working with old versions of files. The 3D models from all IFOA members and from other design consultants and subcontractors were integrated

weekly and reviewed collaboratively using Autodesk Navisworks by the entire team at the Big Room or virtually using online collaboration technologies, i.e., GoToMeeting™ or Webex™. Various software tools were used by the team members to design their section of the hospital, as shown in Table 9–3–5. At the start of the design process the team began with a total of 4 or 5 multi-discipline 3D models which grew to over 12 Revit models and over 300 3D AutoCAD-based 3D models and thousands of associated permit, construction, and shop drawings. At the time of the writing of this chapter, the team has produced over 40 gigabytes of 3D models and documentation that is hosted on 8 servers at various home-office locations of the firms working on the project. All information is available to any of the team members from anywhere and in real time on the ProjectWise server network.

Because of the intense collaboration and lean techniques used on this project, it was a continuous learning experience for all involved, regardless of their prior background. The design process is described in greater detail below.

The use of a virtual model of the facility (Figure 9–3–3) both facilitated and required close collaboration among the project team and led to both anticipated and unexpected benefits. Among the expected benefits were:

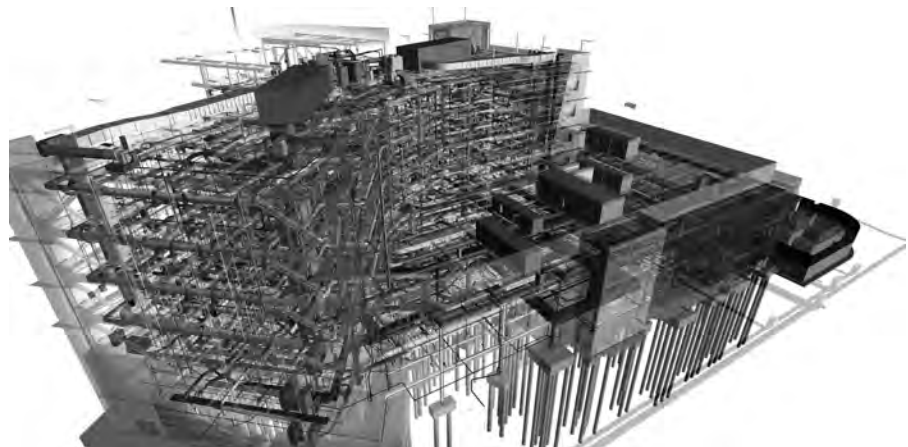
For the client: greater understanding of how the facility would serve patients, doctors, and nurses, and potential reduction in time and cost to build the facility because of lower risk to team members and corresponding reduction in contingency costs, errors, and changes

- For the designers: how design decisions would impact the facility and influence its constructability and cost and greatly reduce field conflicts and clashes

**FIGURE 9–3–3**

Facility assembled in computer before it is built onsite provided advantages to entire project team: fewer errors, better collaboration, better understanding, and more prefabrication of assemblies.

Image provided courtesy of Sutter Health.





- For the contractor and trade contractors: how the facility could be efficiently constructed and phased, how materials and offsite prefabricated assemblies could be installed and the ability to use the model for most of the quantities needed for target value analysis.

### ***The Painshare/Gainshare Plan***

The goal of designing and constructing to meet a target cost was supported by writing a unique contract clause that specified how cost savings achieved by any member of the project team could be shared by all members of the project team (including the owner). Since this contract agreement was an important contribution to the collaboration among team members, it will be described here in some detail. The following are extracts from the incentive fee plan developed by the owner for this project.

#### *Summary of Plan*

In essence, this plan is very simple. Subtract the cost of the project from the amount of funding available from the owner and that is the profit for all IPD members. To the extent that the final profit is more money than the participants normally expect, that is the “gainshare” or incentive. To the extent that it is less than they would expect, that is the “painshare,” or risk. The maximum extent of the painshare is that the profit falls to zero, i.e., if the cost of the project is greater than the available funding, that difference will be paid by the owner. Or to put it another way, the risk to the non-owner IPD participants is limited to the total value of their expected profits. On the other hand, if the actual project cost is less than the target value, the benefit is split equally between the non-owner IPD members and the owner. Beyond a specified tier the proportion going to the non-owner IPD members increases to 75 percent, then beyond another tier the profit is capped and all additional savings go to the owner. Progress payments of to-date profit are paid at key project milestones. The payments to each firm are based on that firm’s percentage of the total IFOA budget (that portion of the budget for which the signers of the IFOA agreement are responsible). While there are additional complexities in the contract, they are not pertinent for this discussion.

#### *The Underlying Principles*

Maximize the creation of value from the owner’s perspective, while minimizing waste.

Increase relatedness among members of the design and construction team and throughout design and construction. Approach each problem with an attitude of inquiry, first asking “who might I ask to help solve this problem” and

then focusing on jointly exploring the problem, rather than coming up with the solution.

Increase relatedness among the members of the design and construction team. Strangers cannot be expected to deeply collaborate and achieve higher levels of performance.

Pursue coordination of work on the project recognizing that a project is a network of commitments, coordinating work through requests and promises and pull scheduling. The goal of project management and planning is to articulate and activate the network of commitments.

Constantly seek to maximize the value at the project level, not at the individual or enterprise level, by asking how I can create coherence between the goals of individuals or team members and the project as a whole. Educate all team members to think about gain/loss for the project, not the firm. Keep an open mind on how the total team can contribute to a better solution.

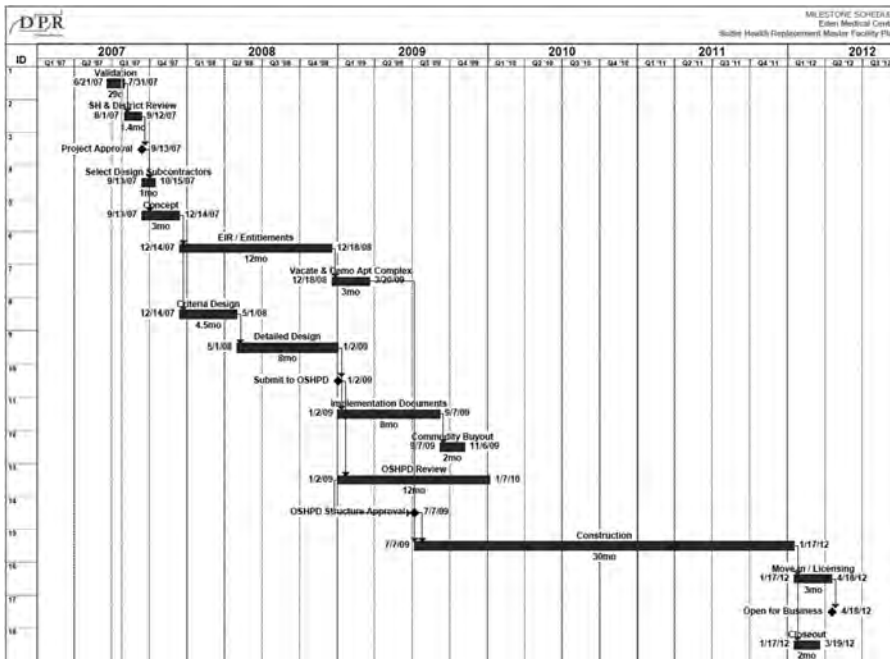
Approach each action with a commitment toward continuous improvement; if the team does not “learn as it goes,” the project will not benefit from learning opportunities for which the project has paid.

### **9.3.3 Design (Preliminary and Detailed)**

This project is one of the first to use the OSHPD phased plan review process which was introduced after many years of industry collaboration with OSHPD to facilitate efforts to comply with California’s Seismic-safety legislation SB 1953 that was passed in 1994 in response to the Northridge, California earthquake. This legislation imposed two key important design and construction deadlines on all acute care facilities in California. The first was that by the end of 2012 all acute care facilities should be fully operational and compliant with the state’s seismic standards. The second was that, if by the end of 2008, a noncompliant acute care in-patient facility had submitted their structural and foundation designs to OSHPD for review, it would then qualify to submit for an extension of the deadline by two years to the end of 2013. Sutter Health, as a matter of overall strategy, absolutely intended to meet both deadlines.

This law required most healthcare owners to undertake a massive design and construction effort on various projects. It resulted in significant challenges for those owners and their supply chains and created a strain on resources. For example, in 2006 Sutter Health alone had in mind a capital investment program of \$6 billion over the following seven years.

The Castro Valley project team comprised of the 11 signatories of the IFOA began to confront those challenges at the end of the validation phase in which the team committed to Sutter Health that they can design and construct a facility that meets their goals within the target budget and schedule.

**FIGURE 9-3-4**

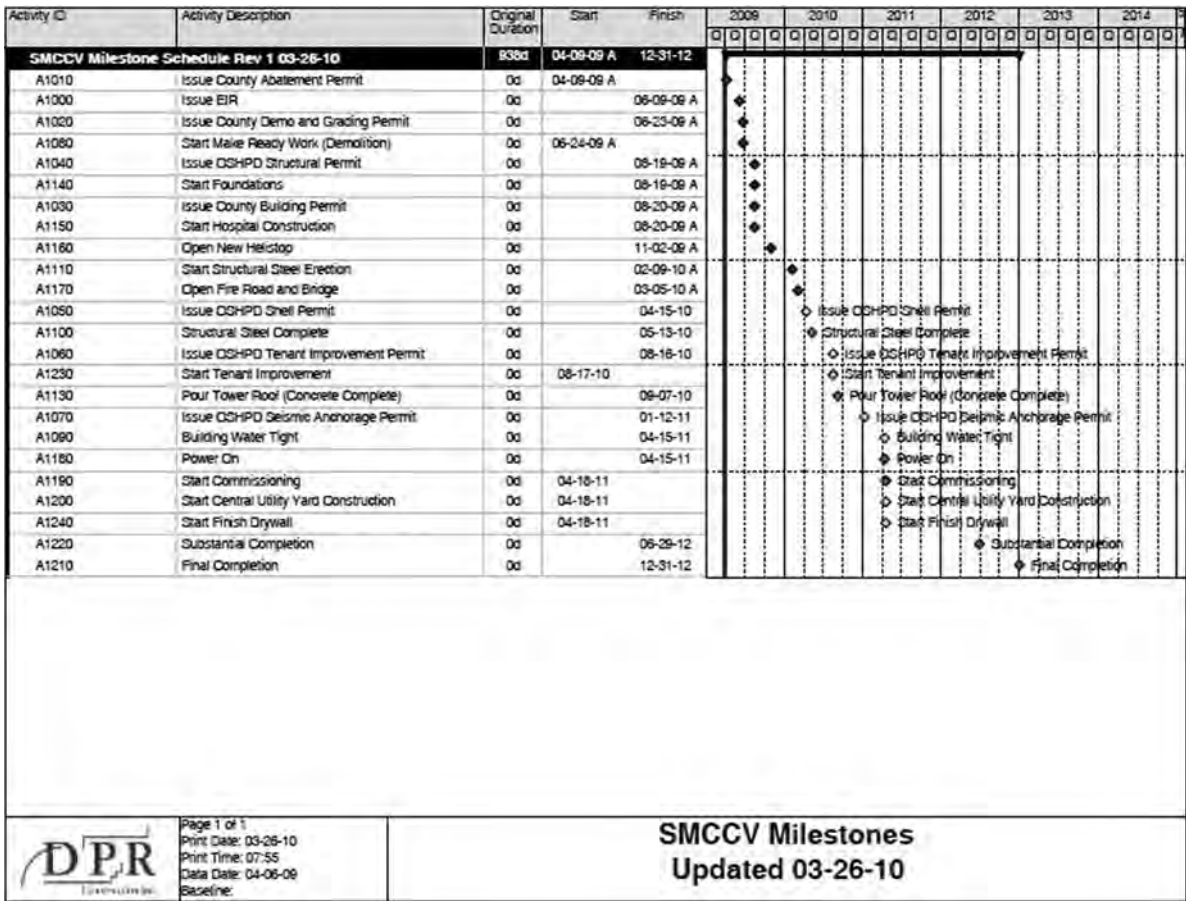
Baseline schedule at the end of the two-month budget validation phase (7/3/07) showing start of conceptual design on 9/1/07 and submission of OSHPD structural package 16 months later on 1/2/09.

Figure provided courtesy of Sutter Health.

The original schedule phases allowed for a four-and-a-half-month criteria design phase, followed by an eight-month detailed design phase which would complete this phase of the project at the end of the 2008 deadline. This was followed by an eight-month implementation documents phase during 2009 in parallel to the OSHPD plan review process.

Consequently, when the design phases started at the end of September 2007, the team was under tremendous pressure to start producing documentation as soon as possible in order to meet those intermediate deliverable deadlines, knowing that from past experience no project of this magnitude had been designed in less than 24 months. See Figure 9-3-5 for revised milestone schedule.

At the same time, a subgroup including Sutter Health's project manager, DPRs lean coordinator, with assistance of two team members from Ghafari Associates, began to brainstorm how to best proceed with planning and streamlining the design process. Various approaches were explored and eventually the team agreed that a deep understanding of the design process, its internal dependencies, and constraints are fundamental to making that process as efficient as possible. They decided to implement process mapping (a collaborative and cross-disciplinary workflow mapping approach) to illustrate visually and in greater detail the team's current thinking of how they planned to execute the

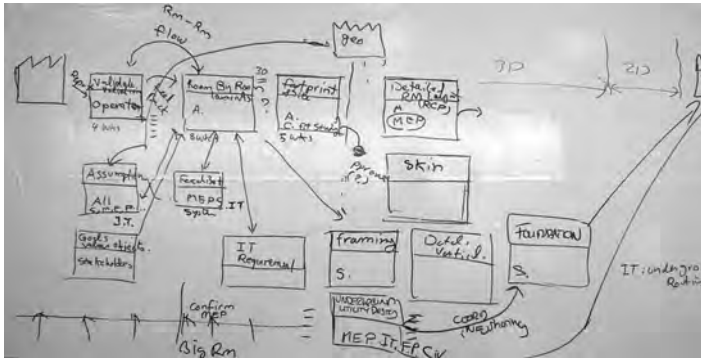


**FIGURE 9-3-5** Milestone schedule as of 3/26/10 showing phased OSHPD reviews and project completion by 12/31/12 (on target).

Figure provided courtesy of Sutter Health.

project to meet the existing milestone schedule. This focused the teams on only producing what was needed and to eliminate unnecessary design efforts.

The process mapping started in November 2007 and continued throughout design and construction almost on a biweekly basis. The process started simply by the key team participants for all companies meeting and discussing various streams of work (see Figure 9-3-6), then they began to stick Post-it notes on the white board which were then entered into a specially formatted Visio diagram and printed on the wall before the start of the next meeting for further review and evolution (see Figure 9-3-7). This process immediately


**FIGURE 9-3-6**

The first attempt at mapping the design process based on the baseline schedule.

Image provided courtesy of Sutter Health.


**FIGURE 9-3-7**

Detailed mapping of the design process.

Picture provided courtesy of Sutter Health.

identified that there were significant areas that required a deeper understanding to eliminate the risk of rework in the design process. Notable examples:

- Lack of clarity on overall project goals.
- Who were the stakeholders?
- What was the relative importance of each stakeholder?
- What were the most important goals of the project?
- How important were the goals relative to each other?
- The clinical program was not fully locked down which posed a significant risk of rework to the project if the team proceeded with design and then the program changed.
- Lack of clarity on what the team will deliver at the end of each “classic” milestone. For example, as each discipline discussed with their

peers what they will deliver at each of the gate reviews (criteria design, detailed design, and implementation documents) it became evident that there was a significant mismatch in expectations.

- Lack of a deep understanding of the dependencies between the environmental impact report (EIR) and design processes

On this project the owner had not yet secured the entitlement to build the hospital and it needed to go through that public EIR approval process in parallel to the design process. It was unclear at the start how long that process would take and the exact interactions between that process and the in-progress design and OSHPD approval milestones.

The team identified various risks to the project if the team delivered the detailed design documents to OSHPD and then proceeded with implementation documents during the OSHPD review. If that was allowed to happen the team could be making coordination changes to the documents they just submitted as final documents. At the same time they would be receiving review comments from OSHPD which, by the time they were received, may no longer be relevant to the coordinated design.

The architectural and MEP teams were not clear on how much work would be needed from them to support the first OSHPD milestone for review of the foundation and structural steel design.

- Lack of clarity on how to design a facility that met requirements within the target budget

The construction team's expectation had been to produce cost estimates at the scheduled milestone reviews (after the design was done) and give input to the design team on budget. This approach would, however, take too long because by the time a cost estimate was available, the design would have moved on and made that estimate invalid.

Decisions made to avoid or minimize the above risks:

- Set clear goals

The team produced a document called "Owner's Goals" and made these part of the contract. The intent was to secure agreement that the team's ability to meet these goals would define the success of the project. This proved one of the most important but underappreciated actions the team took. It clarified that, while the one non-negotiable constraint was staying within the budget, a central goal of the project was transformation of clinical flow within the building. Having that as shared knowledge

accelerated decision-making everywhere in the design process. It was not permissible to save money by compromising the flow of clinical services. The owner's healthcare planning consultant's (Navigant) continued presence through most of the design work was an important element in making many decisions that supported the owner's goals for hospital operation.

- Identify design planning strategies to deliver a *fully informed* set of 100 percent complete foundation and structural design drawings by the end of 2008 (see Figure 9-3-5)

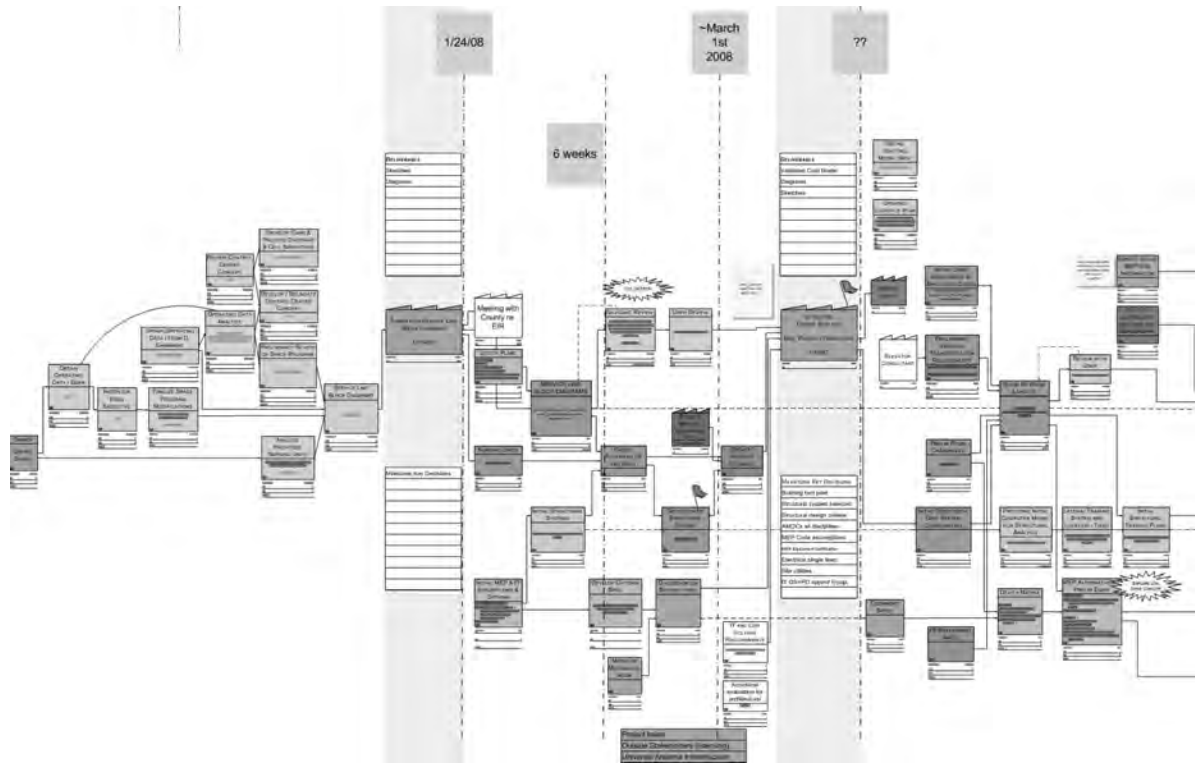
The design team had to follow the rather ruthless logic that dictated that if the lack of a final space usage program (known within the hospital industry as the clinical program) would put prior design work at risk of partial or complete rework then that prior design work was not to be done in the first place. This drove the team to get from the owner what is a rather unusual commitment to finalize its clinical program by a certain date provided by the team and thereafter to *never* come back to request a change to that program. The owner was willing to do that because the extensive planning and thinking that went into that request clearly showed that not doing this would put both the budget and the schedule at risk.

- Better understand the dependencies between the EIR process and the design process

It was necessary to focus the team on improving their common understanding of the shared project plan by replanning the process map on the regular basis.

This meant that while the clinical program was being developed further by the operational planning consultants (Navigant), the architect (Devenney), and Sutter Health, the other design teams focused their efforts exploring efficient systems choices and layout options that could best support the evolving clinical requirements. At the same time they involved their discipline specific trade contractors in the cost, quality, and constructability issues of those various systems. This effort was primarily an exploratory effort that did not require detailed design 3D models and documentation.

Results from the intensive design planning effort resulted in identifying two key last responsible moment (LRM) milestones of April 2008 to finalize the medical program and June 2008 the departmental room layouts. Both were required before it was possible to lock down the floor plan layouts and the rest of the team could begin to produce their detailed design deliverables. Fortunately, Sutter Health was able to accelerate its internal decision-making processes as they could see the impact of those decisions on the entire project and thus both target dates were met.



**FIGURE 9-3-8** Workflow (process map) to lock down the medical program.

Image provided courtesy of Sutter Health.

**FIGURE 9-3-9** Early design process mapping to identify key design milestones at the system level.

Image provided courtesy of Sutter Health.



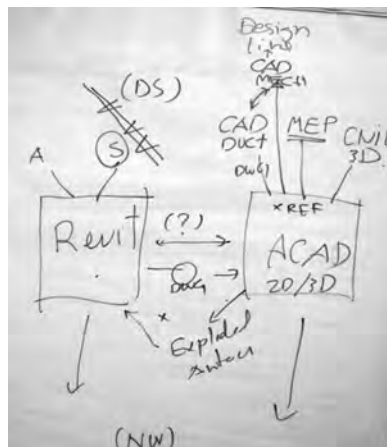


The most important conclusion from this detailed design planning effort was that it gave the team a point of reference and a common understanding of what they collectively needed to do to support the overall project schedule and goals. Moreover, the owner, instead of having to prematurely release an incomplete medical program and have the team proceed with a massive design effort starting in November 2007, had the opportunity to truly finalize the program by using four to five additional months to truly lock down the departmental layouts to achieve the most efficient use of space and very significant reductions in potential detail design changes.

### **How BIM Fit in the Overall Design Plan**

The team's agreement from the beginning was that the project would be designed to maximize the use of 3D technologies. The goal was to use the models in every way possible that would identify and eliminate risk, particularly in areas of handoff from design to construction. This goal evolved to use 3D technologies to streamline information exchanges digitally (using the same 3D model information) from design to detailing to fabrication. In addition, this information would be to the extent possible to accelerate the quantity takeoff and estimating processes so that the team had faster feedback on how the design was tracking against its target cost.

A careful consideration of the software options and the capabilities of the team members in April 2008 resulted in the selection of Revit as the platform for the Architectural and Structural Disciplines and AutoCAD as the base platform for everything else including Mechanical, Electrical, Plumbing, Fire Protection, and Low-Voltage Systems (see Section 9.3.5).



**FIGURE 9-3-10**

Extent of BIM planning at the early stages of design.

Image provided courtesy of Sutter Health.

Together with selecting the BIM platforms, the team needed a robust system that would give the team controlled and real-time access to those files from various locations across the country. Thus the resultant selection and deployment of ProjectWise for all document management and real-time file sharing.

As the process map for the design process evolved, the team began to identify for themselves the last responsible moment (LRM) to begin the multidiscipline 3D model and multidiscipline coordination based on the 3D model. With the exception of the architectural and structural disciplines, which started to develop their 3D model content prior to June 2008, the majority of the MEP/FP teams did not need to start their 3D model-based design efforts until later in the year and focus on only what was necessary to meet the requirements of the submitted OSHPD package at the end of 2008. The main focus was on producing 3D coordinated content and to delay as much as possible the production of required 2D documentation. For example, Figure 9-3-11 shows the final structural model just before the team submitted the first review package to OSHPD; Figure 9-3-12 shows the supporting mechanical, electrical, plumbing, and fire protection 3D models and design effort that was necessary to fully inform that package to minimize late changes. This effort was carried entirely in the 3D model and no 2D documentation was produced at that point in time.

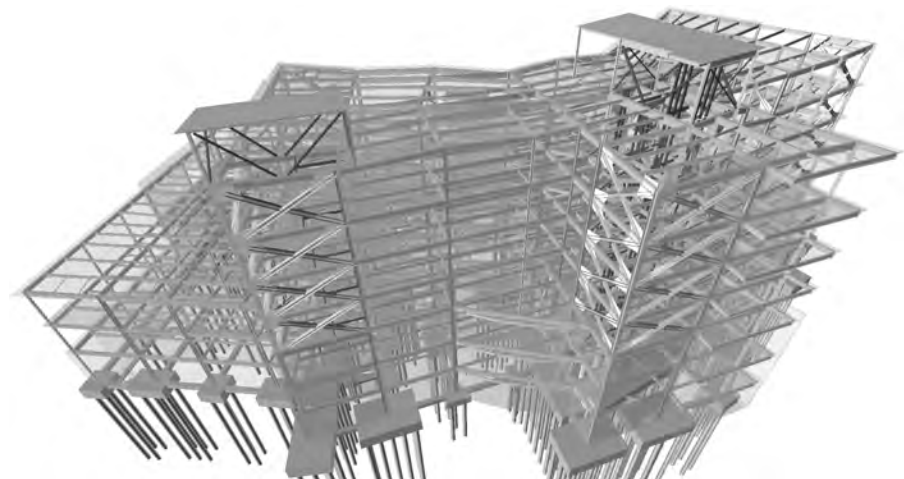
### ***Decisions Made to Support Team Collaboration***

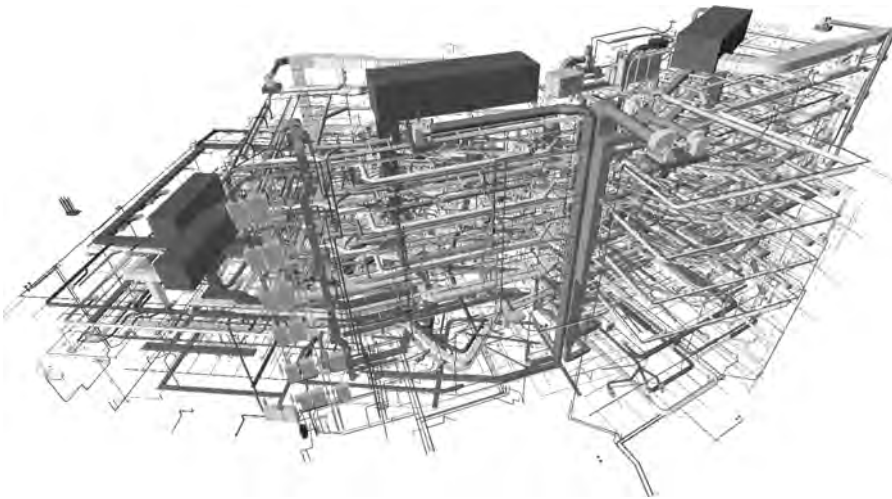
Around April 2008 the team began to explore how they would structure themselves and operate to support the project workflow. The most pressing issues were to identify a collocation strategy, find a proper workspace, and decide how to interface when collocated and when not collocated.

**FIGURE 9-3-11**

Final structural design model.

Image provided courtesy of Sutter Health.





**FIGURE 9-3-12**  
MEP/FP system model that supported the structural model. (See color insert for full color figure.)

Image provided courtesy of Sutter Health.

Locating the entire design team in one place (the Big Room) was not favored for a variety of reasons. A space large enough for the entire IPD team was too expensive. In addition, it would have split the production staffs for each firm into a Big Room core staff and remote office staff with continual shifting of resources between the two locations as requirements dictated.

Eventually the team settled on a biweekly face-to-face meeting at the Big Room for two to three days with virtual meetings scheduled on an as-needed basis. The format of the biweekly meetings was roughly as follows:

- About four to eight hours was allocated for overall project planning and process mapping with an eye at key project milestones and trying to ensure that those milestones were always met.
- About two to four hours was allocated to multidiscipline design review primarily using the 3D model as a tool. It is important to note here that this was not a clash review, but rather a top-down review of the larger design issues and their cross-discipline impacts.
- A dedicated time at the start of the meeting to status commitments and tasks that are completed and not completed
- A dedicated block of time at the end of the meeting to make commitments for tasks that need to be completed before the next planning cycle

During the biweekly 3D-based design review, hundreds of design, constructability, sequencing, and workflow efficiency considerations were identified and resolved. New issues were identified and resolved each time the various design models were integrated and collectively reviewed. This model-based

**FIGURE 9-3-13**

Design review of elevator during early design.

Picture provided courtesy of Sutter Health.



design review process allowed the entire team easy and immediate access to all the design discipline's information in one place rather than having to rely on interpreting a set of fragmented representations from many discipline drawings and standard details. In addition, having the cross-discipline team present in the Big Room was fundamental to bringing many of those issues to surface and getting them resolved much more quickly than would have been possible using the traditional drawing review process.

During intermediate weeks when the team was not fully collocated in the big room, they made productive use of online collaboration tools, i.e., GoToMeeting and Webex™, to continue their model-based design reviews virtually. Using these tools, they were able to engage in multiparty discussions about the design utilizing the work-in-progress 3D model.

Through the model-based design review process the team was able to identify and avoid hundreds of design issues during the early stages of the design based on incomplete information rather than waiting until full review sets had been assembled by multiple design disciplines. Figure 9-3-13 shows multiple design teams working on the design review of the elevators and illustrates how this process was used.

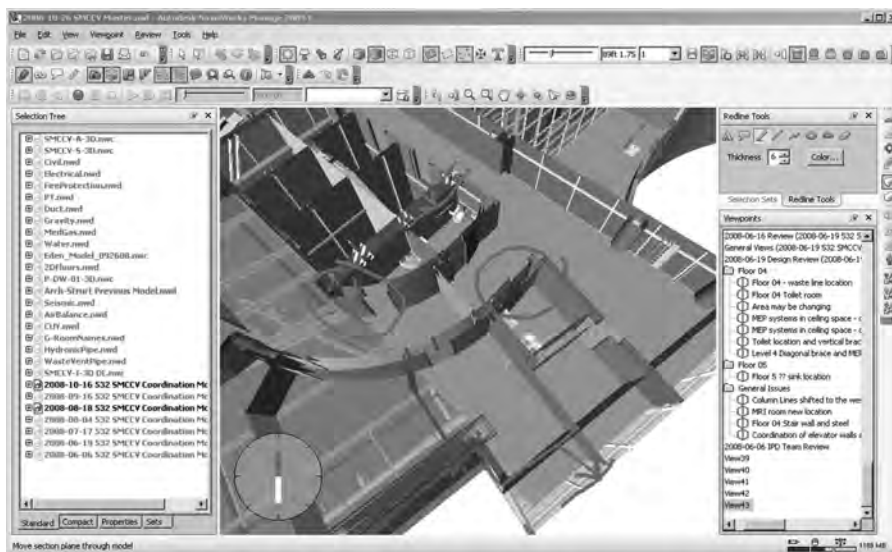
### ***Detailed Design and Coordination of Elevators***

Structural changes to the building due to elevator equipment were identified as a major risk item. The team mapped out strategies to reduce those risks including the early selection of the elevator subcontractor to allow it to receive accurate and detailed information about the elevator equipment as soon as it

could be reliably produced. This information became available approximately in June 2008 and 3D models from the elevator 2D drawings were created and compared to the in-progress architectural and structural design. This immediately identified discrepancies between the actual elevator equipment sizes and space for the equipment. Making the necessary changes to the required space for the elevators in turn affected the adjoining main building columns, shear walls, and brace frames which had to shift by approximately one foot in both directions. This in turn affected the accessible corridor width and eventually resulted in pushing the edge of the slab and exterior of the building by three feet. The architectural and structural design teams were able to accommodate those changes to their in-progress early design thinking and proceed with more certainty toward completing their designs before the construction documents were submitted for review by OSHPD.

### Design and Coordination of Stairs

Stairs were another area of risk that the team identified during the planning phases especially because of concern about the tight construction tolerances in the building. Early selection of the stair fabricator and the team's decision to have their 2D shop drawings modeled by the steel fabricator so that this information could be reviewed against the in-progress design models immediately identified conflicts with the architectural clearances at landings and vestibules and conflicts with the in-progress structural steel shear walls and diagonal bracing around the stairs. These problems would normally have gone undetected until much later if a conventional design process had been used.



**FIGURE 9-3-14**

Model review of stairs showing areas of conflict and suggested wall movement. (See color insert for full color figure.)

Image provided courtesy of Sutter Health.

As the design became more detailed, additional 3D-based design and constructability reviews including weekly MEP/FP clash detection meetings began to be scheduled outside of the dedicated biweekly meetings. In addition, some of the team members opted to move their design and detailing staff into the Big Room to increase face-to-face interaction and accelerate problem solving. Workflow planning continued on a biweekly basis with a half-hour daily check-in to status ongoing activities.

The above process evolved slowly and somewhat painfully over time. Each evolution simply tried to solve problems the team was facing at that time. The daily call-ins to review the status of each design deliverable were key to keeping design moving fast and in the right direction. This evolutionary process together with the shared gain/loss of the project team helped to achieve maximum levels of buy-in to an efficient and cost-effective design process.

### **9.3.4 Technologies Used to Support Project Team**

As previously noted, the assembled team used 3D modeling as a risk management strategy from the start of the project. While many of the team members had some prior experience with 3D, none except the DPR Construction and Ghafari had worked with it on such a large project or where so many functions would be coordinated using the model.

The first challenge was to select the software tools they would use. Should the entire team use a single platform? Will this platform support everyone's needs? Alternatively, should they all select the tool of their choice and somehow integrate those tools together in Navisworks?

After much facilitated discussion, the team made the strategic decision to maximize the potential from design to fabrication using 3D model data whenever possible. As a result the following choices were made:

- To use a single platform for the architectural and structural teams because they needed to work very closely with each other.
- To use a single platform for all systems that required routing through the building including mechanical, electrical, plumbing, electrical, and fire protection as they needed to work very closely with each other during design and later for detailed coordination and clash checking.
- Whenever feasible, the design and detailing teams would select tools that will allow design information to flow without translation or recreation from the design models to the detailing models, and then to the fabrication equipment.
- Other design and detailing systems might be introduced as other trade contractors are selected and integrated into the overall project workflow.

Digital interoperability was resolved as follows:

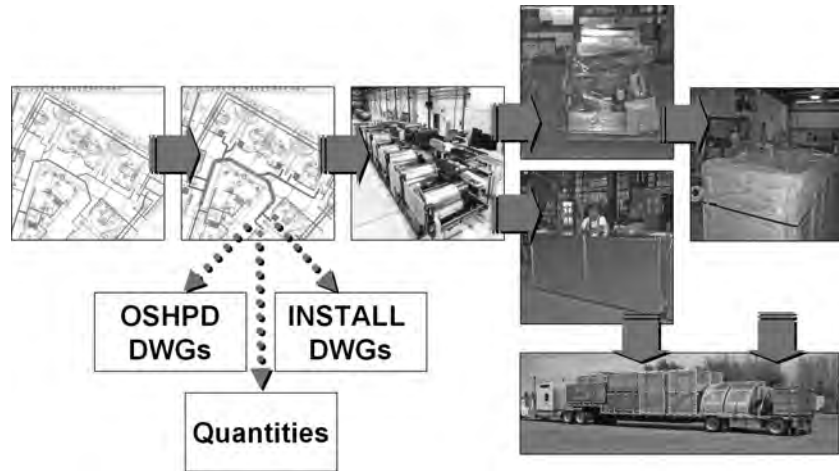
- Each discipline team member must have the capability to pull the latest model information at any time and in a format that is compatible with their native modeling software.
- Each week the architectural team posts their native design model as well as specifically defined views in 2D and 3D AutoCAD format of their model to ProjectWise.
- Each week the structural team posts their native design model as well as specifically defined views in 2D and 3D AutoCAD format of their model to ProjectWise.
- All mechanical, electrical, plumbing, fire protection and other AutoCAD 3D models will be hosted on a real-time basis on ProjectWise. Those files will reference any other files in real time and must be checked out and returned to the system when they are worked on.
- Decisions to upgrade software versions must be approved by the entire team before any one team can upgrade its tools.
- Object enablers for all software tools were shared across all firms. Object enablers are programs that allow users to read, but not change, the information associated with objects in a BIM program like Navisworks although they do not have the authoring program that was used to create the object model. For example, a CAD Duct object enabler will allow a user to understand information associated with ducts in a program like Navisworks although they do not have the CAD Duct program on their machine.
- If new team members are added that use different 3D authoring tools they would be required to deliver their models in formats that can be linked or imported by the two primary CAD (or BIM platforms) and in return the IFOA teams will translate and provide their information in 3D formats that can be read by those other systems.
- Model-based design review meetings will be facilitated using Navisworks which is used to collect the latest copies of all design information in 3D and 2D for the purposes of the cross-discipline review and to publish a composite entire building model on a weekly basis so that it can be accessed and reviewed at any time by any team member who may not have all the authoring software.

In parallel, the team began to investigate how to leverage the information within the in-progress 3D design models for various other purposes including

**FIGURE 9-3-15**

This shows the use of BIM to support the goals of creating OSHPD permit documents, generate quantities for cost estimates, and support fabrication and field layout and status reporting efforts.

Shop production photos courtesy of Superior Air Handling. Image provided courtesy of Sutter Health.



model-based quantity takeoffs and cost estimating, line of balance scheduling, automated code checking, energy simulation, and 4D sequencing, among others. Some of those explorations proved to be successful, for example, cost estimating. Others were impractical for large-scale implementations, for example, automated code checking, and others continue to be evaluated for potential use, such as line of balance scheduling and 4D construction simulation.

### ***Problems and How They Were Addressed (reference Table 9-3-5)***

1. **Collaboration between MEP designer and subcontractor:** Single line diagrams for mechanical and piping systems were not easily integrated into CAD Duct. Designer switched to CAD Duct Design Line product and sometimes used libraries provided by the trade contractor to create design. Use of nonstandard fittings flagged situations where cost could be saved by redesign using standard fittings.
2. **Keeping track of detail model of drywall with design changes:** The team used a manual process to keep track of the changes to Revit model since they were not automatically reflected in Strucsoft Metal Wood Framing model which was used to generate the layout of metal studs for the drywall. This required frequent updating of the Metal Wood Framing model. Currently there are not good tools for metal framing that allow for a seamless integration of Revit changes. The DPR team is doing this manually to keep track of the changing design.
3. **Transfer between structural analysis and design programs:** Data transfer between ETABS design analysis and Revit was manual (only column lines were transferred automatically). This required the team to manually update the Revit model.



- 4. Model use beyond Design and for Estimating:** The goal of the modeling process was to use the model for much more than just design. One of the successful efforts on this project was the use of the model for estimating. When the process was started the DPR and DGL team realized that the modeling program (Revit) had the capability to incorporate the information and parameters that DPR's estimators needed to enable an automated estimating process. DGL and DPR collaborated to add a DPR-generated shared parameter .txt file into the Revit Architecture program to facilitate the downstream quantity takeoff and estimating process. This is described in more detail in the model-based estimating process section.
- 5. Lack of interoperability between Revit and Tekla models:** Revit models cannot be imported directly into Tekla. Revit can export an IFC file which can be imported into Tekla, but only the shape information is imported and size data is lost. To work around this problem, reference models were created which required more manual effort.
- 6. Model size issues:** As the architectural model size increased in size, the design team had to split the Revit model first into exterior and interior models and then the interior models had to be split into three other models. The team had to think hard about strategies for model creation and maintenance so that they could continue to add the detail required by other disciplines for accurate coordination. This continued to be a difficult issue as the requirements for detailed design coordination far exceed the capability of the software for acceptable performance. Other tools the team considered faced significant performance limitations and in some cases are not even capable of opening the model files. This remains a significant problem for use of BIM on large projects with detailed objects.
- 7. Lack of interoperability between Revit and CAD MEP models:** There are also significant interoperability problems between the two main model creation platforms used during design and detailing as the teams pushed these systems to their limits even on the latest hardware. The issues are under control and have not stopped the team from producing what they needed to produce. Various workarounds were used. An example is the reflected ceiling plan exported from Revit models which are critical to completing MEP coordination. These are stripped of all the ceiling grid information when they are exported to 3D AutoCAD models. This caused them to lose their 3D elevation information when they are used for 2D drawings that are needed for submittals.

**FIGURE 9-3-16**

Combined Navisworks model of all mechanical and fire protection systems. Each system has a unique color. (See color insert for full color figure.)

Image provided courtesy of Sutter Health.

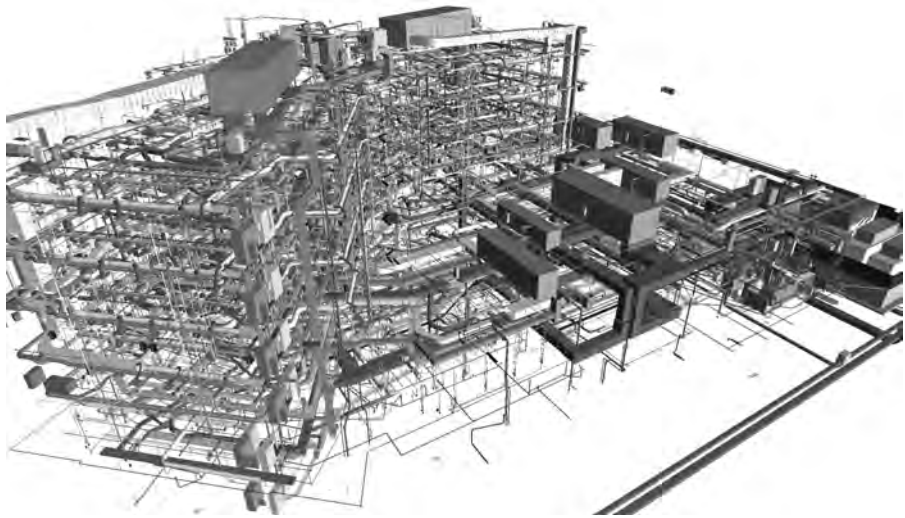
**FIGURE 9-3-17**

Photo of Autodesk Navisworks model and actual photo of site as of February 20, 2010. This shows how the project is being built twice: once virtually and once in the real world (designing for fabrication and preassembly). At this point the steel erection is about 30 percent complete. (See color insert for full color figure.)

Image provided courtesy of Ghafari Associates.



### *Use of a Federated Document Collaboration System*

The IPD team used the Bentley ProjectWise online Model/Document Management and Collaboration System for model management. This was necessary because of the large number of project participants in multiple locations. This system allowed a dispersed team to develop models, submit them when ready,

**FIGURE 9-3-18**

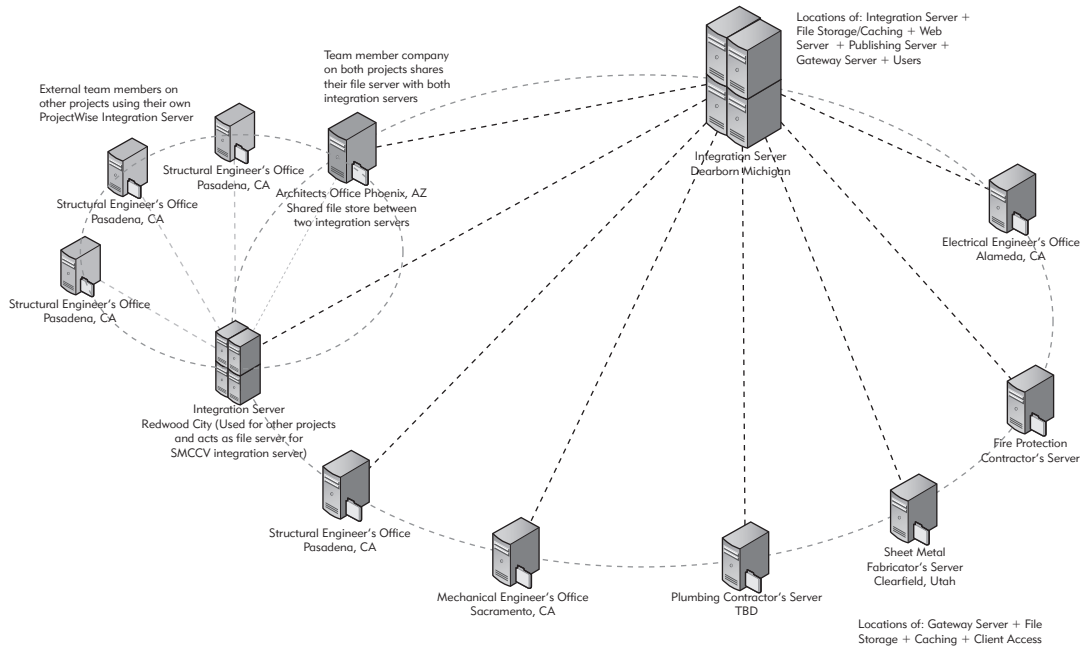
Web-based virtual participation using GoToMeeting™ between team members at home office and site. Courtesy of The Engineering Enterprise.

Image provided courtesy of Sutter Health.

and for the rest of the team members to immediately see them. Bentley's ProjectWise system allowed the team to deploy eight servers at various locations so that team members could develop models and save them without having to go over the Internet. With local access to the latest models on the server nearest to them the team members can coordinate much more effectively and efficiently. See Figures 9-3-19 and 9-3-20.

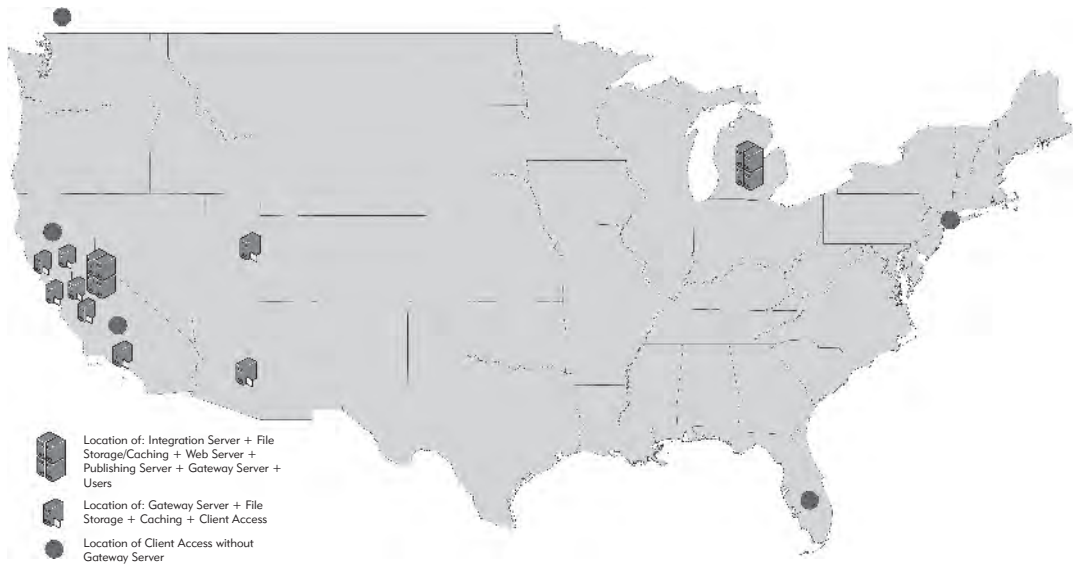
The Bentley ProjectWise system allows the project team to:

- Access immediately the most current documents from their office desktop or laptop
- Create various levels of access depending on project role. This access allows users to control access for various groups and can be applied to folders, sets of documents, and to even a single document
- View the document set using a simple Windows Explorer-like view with the same functionality of drag and drop like Windows explorer
- Create versions of the documents
- Track audit trail for the documents
- Check-in and check-out functionality for the documents
- View and markup documents in the document viewer
- Create automated notifications based on changes to documents or folders



**FIGURE 9-3-19** The “Federated Model Management” Architecture for document and model collaboration.

Image provided courtesy of Sutter Health.



**FIGURE 9-3-20** The map shows the location of the model servers.

Image provided courtesy of Sutter Health.

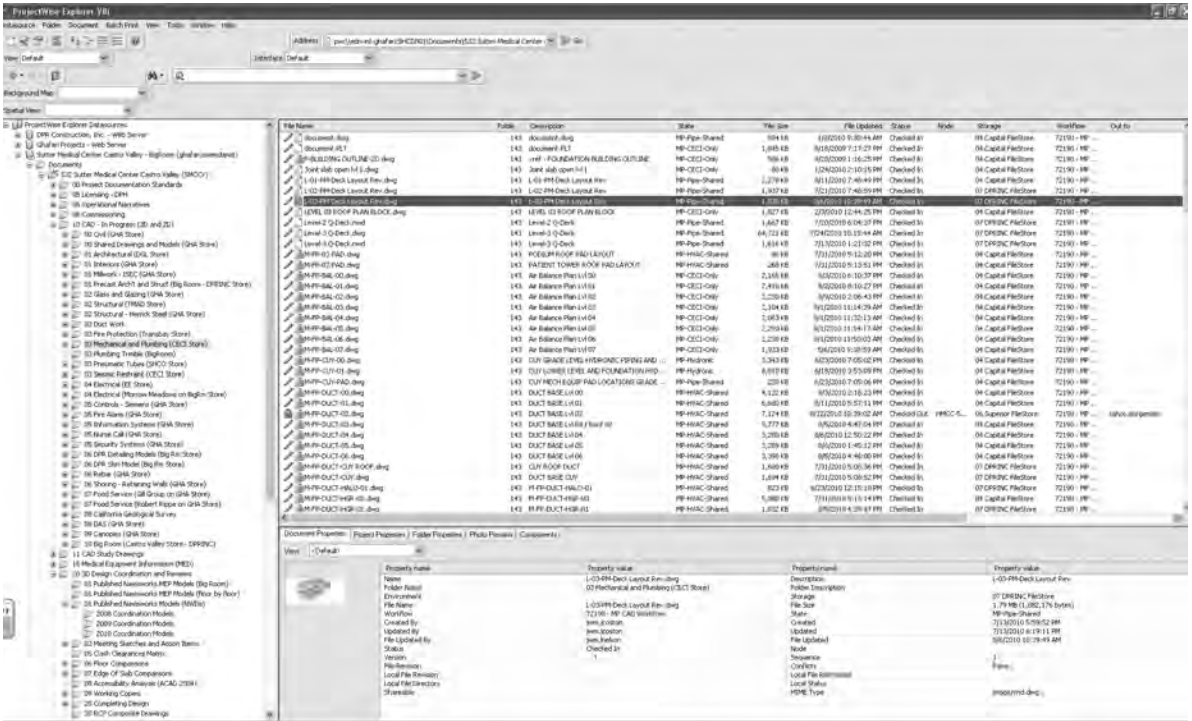


FIGURE 9-3-21 A snapshot of the Bentley ProjectWise Collaboration System.

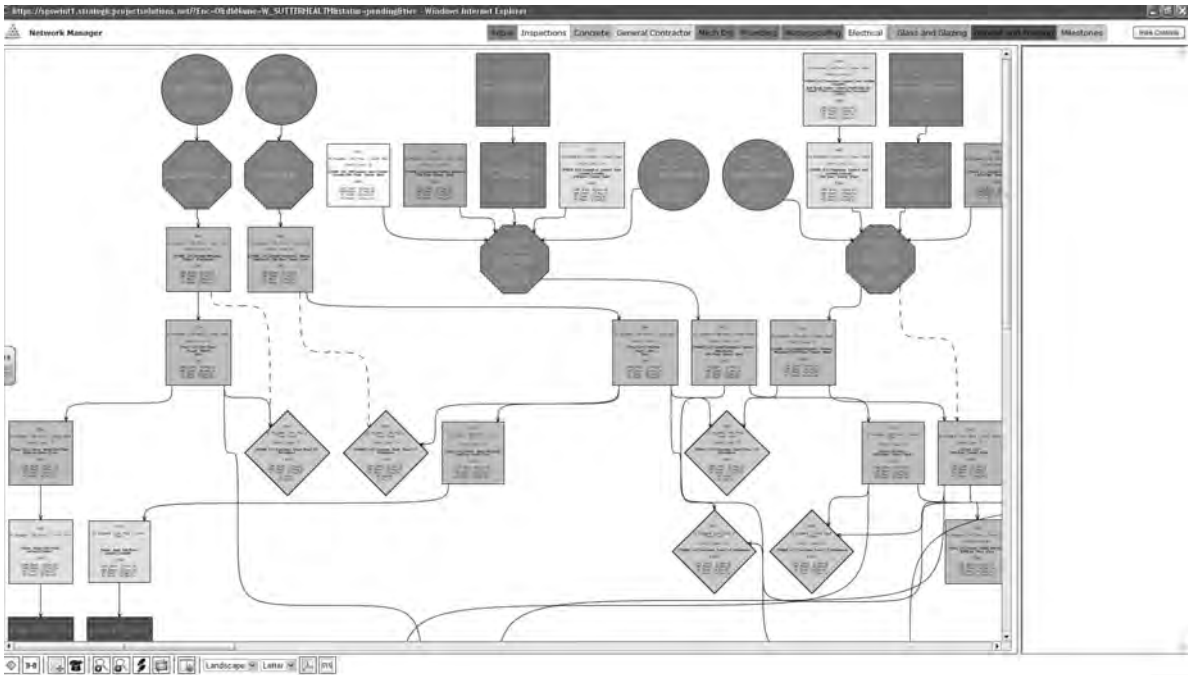
Image provided courtesy of Sutter Health.

### Process Mapping and Commitment Tracking Using Strategic Project Solutions Production Manager

The project team used the Solutions Production Manager (SPS) for process mapping and commitment tracking. The process mapping was initially done using the traditional sticky-note process on the walls at the Big Room. This data was then captured into a precedence relationship diagram using Microsoft Visio. As the complexity of the map grew and the updates started, this process was migrated to use the SPS Production Manager which was able to manage the schedule data and calculate the schedule dates.

### Tracking Potential Risk and Opportunity Issues During the Design

As the design progressed, there was continual need to track the cost of the design and ensure that this did not exceed the target budget. This process is described in the following section. In addition, potential risk and opportunity issues were raised that could increase project cost unless they were carefully



**FIGURE 9-3-22** The process mapping network and look-ahead network plan for project team (teams denoted by shading).

Image provided courtesy of Sutter Health.

evaluated and appropriate actions taken. Table 9-3-6 shows a spreadsheet where these issues fell as of late February 2010. This was prominently posted on the wall of the Big Room where all team members could see it. These issues were discussed by the Core Group on a biweekly basis to ensure that appropriate follow-up actions were taken.

### 9.3.5 Model-Based Cost Estimating

#### *Introduction*

Target value design (TVD) or target costing was adopted from the very beginning of the project. The Lean Construction Institute defines target costing as a practice which incorporates cost as a factor in design to minimize waste and create value. In most traditional project delivery approaches, cost follows design, whereas for the TVD approach cost dictates what gets designed (still subject to owner requirements) to ensure that the target cost is not exceeded. This requires rapid cost feedback to the design team which in turn necessitates extracting quantities from the virtual model and using these for model-based

**Table 9-3-6** List of Potential Design and Construction Problems with Probability of Occurrence and Estimated Cost or Benefit (as of Late February 2010)

Description of Risk or Opportunity	Probability risk will happen	Uninformed Guess	Informed Guess	Confirmed Cost	Assessed Financial Risk
That having 358 items left on 3D correction log means we will have issues to resolve in construction that will cost us money	50%		300,000		150,000
Licensing will require significant changes to the building after we get our OSHPD approvals, shortly before the building opens	80%		50,000		40,000
Mechanical equipment will need to be upgraded to improve energy efficiency of building to have better chance of meeting contractual LEED goal	90%		250,000		225,000
AMOC for Structural Silicone Butt Joints in glazing system	90%		100,000		90,000
Other measures (list them) will be necessary to get project to meet LEED goals	90%	250,000			225,000
That OSHPD will not allow our sliding door AMOC and we'll have to put in swinging doors at ICU with the associated relocations of sinks and plumbing	100%		150,000		150,000
Seismic Sensors Required by OSHPD	99%	100,000			99,000
We will decide we should fully comply with the Tier 4 requirements for generators on this site. There will need to be a plumbing hookup of Urea tanks for generator.	25%			371,000	92,750
Additional seismic testing beyond what has been budgeted will be required. Choice of equipment may be limited depending on if specified equipment receives OSP prior to procurement.	75%		100,000		75,000
Project will need to comply with (insert which one) code interpretation regarding Fire Dampers.	15%		400,000		60,000
Halfin anchors	100%		0		0
The need to install fire sprinklers in elevator shafts	80%	50,000			40,000
Use a single vendor to do all firestop & acoustical caulking	99%	(50,000)			(49,500)
Add smoke and heat detectors in elevator shafts per fire marshal	50%			18,850	9,425
Herrick cost savings under their GMP	90%		0		0
OSHPD change order #09.	50%		250,000		125,000
Structural steel support detail	50%		150,000		75,000

(Continued)

**Table 9-3-6** (Continued)

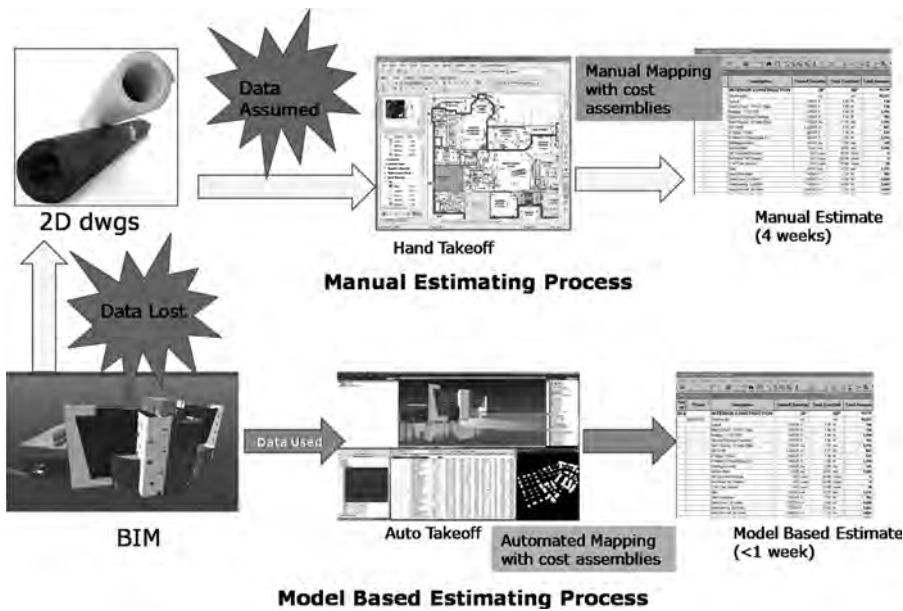
Description of Risk or Opportunity	Probability risk will happen	Uninformed Guess	Informed Guess	Confirmed Cost	Assessed Financial Risk
That because we have not yet produced a list of items that we will NOT model there will be items we should have modeled that will cause coordination issues during construction that will cost us money. – Lower Tier shop drawings being in 2D and not modeled – What else has gone wrong in construction that we can mitigate through more modeling?	75%	500,000			375,000
That because we are not yet modeling all of the framing there will be hidden complications in the design that will cost money during construction to fix.	50%	100,000			50,000
Failure to adequately model envelope in 3D at the shop drawing level will increase the cost of construction by far more than it would have cost to model such.	50%		200,000		100,000
Kitchen equipment is not yet being modeled. May cause major clashes with physical dimension of these (connection points per cuts, sheets are modeled)	50%	50,000			25,000
<b>TOTAL PROBABLE RISK &amp; OPPORTUNITIES</b>					<b>1,956,675</b>
TOTAL MAXIMUM RISK (all risks happen and no opportunities are taken)					<b>3,389,850</b>
TOTAL MAXIMUM OPPORTUNITY (all opportunities taken and no risks happen)					<b>(50,000)</b>

cost estimates. It should be noted that this process started before the contract agreements were officially signed and was fully supported by Sutter Health to ensure that the design met the target budget. In this section, we discuss how this was done and the lessons learned about this process.

### ***The Need for Model-Based Cost Estimating on SMCCV***

The IFOA team members made a huge commitment to use BIM for all aspects of design. As the design was evolving there was a need to identify the impact on cost. The SMCCV team met twice a month in the Big Room to identify these impacts. It was clear that the traditional method of 2D drawing takeoff was too slow to obtain cost feedback every two weeks. The concept of estimating based on a product model was pioneered at Stanford University's Center for Integrated Facility Engineering in early 2000 (Staub-French 2002). The challenge was to use the BIM models as an accurate and reliable source of quantities to reduce the cycle time of cost feedback from eight to two to three weeks.



**FIGURE 9-3-23**

Manual estimating process flow.

Image provided courtesy of Sutter Health.

Model-based cost estimating is the latest step in the evolution of estimating technologies, starting from the hand takeoff of scaled 2D drawings to the Digitizers followed by computer-based 2D takeoff with tools like On Screen Takeoff/Accubid. Using BIM for cost estimating requires integrating the object attributes from the 3D model of the designer with the cost information from databases of the estimator. Using the 3D model to estimate rather than the 2D drawings is not only faster but also eliminates scope for errors and omissions (see Figures 9-3-23 and 9-3-24).

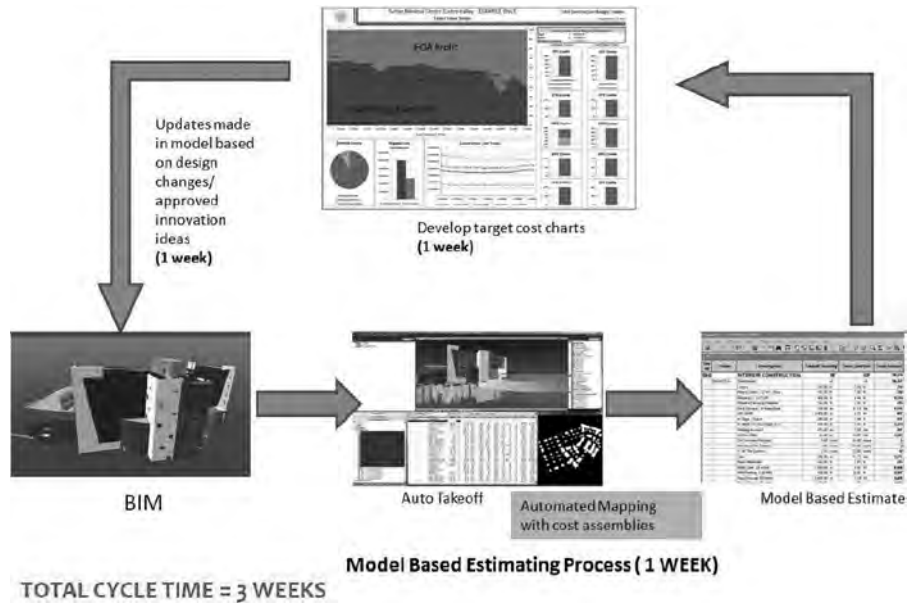
### ***Model-Based Cost Estimating Solutions***

On the SMCCV project every trade uses the modeling tool that best suits their needs for design or fabrication. Although the models can be integrated for 3D geometric clash detection using tools like Autodesk Navisworks, integration of modeling tools with cost estimating abilities has completely different requirements. The team discovered that there were quite a few interoperability problems in taking quantity data from the BIM models to the estimating tools. Adding to this challenge was the variety of cost databases, such as Excel, Timberline, Quickbid, Accubid, and so forth, being used by different companies. Identifying one modeling tool and one estimating tool for the project was impractical given this variety. DPR Construction, Inc. took the lead in identifying how this problem could be solved. Their analysis showed that certain modeling tools were compatible with specific estimating systems. This is shown in Figure 9-3-25.

**FIGURE 9-3-24**

Model-based cost estimating process.

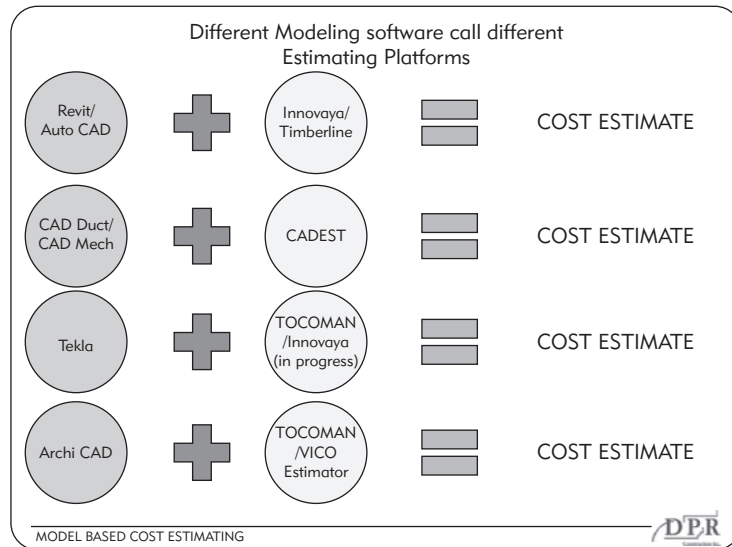
Image provided courtesy of Sutter Health.



**FIGURE 9-3-25**

Compatibility of 3D BIM systems with cost estimating systems as determined by DPR analysis at the start of the project.

Image provided courtesy of Sutter Health.



The two options identified by DPR for model-based cost estimating were as follows:

1. The first scenario was to use a cost estimating solution that worked exclusively with the specific 3D model tool that was being used by the specific trade contractor. For example, CADEst is the estimating tool

for CAD Duct and CAD Pipe, all of which are MAPSolid products and were being used by the MEP trade contractors.

This approach only works if all firms use one of the above modeling tools for their design. This was not the case on this project.

2. The second option that was explored was that to use a neutral platform which allows models from different sources (e.g., Innovaya Visual Estimating, Tocoman, and the like) and link to cost database assemblies that can also be imported from various external databases. In this case, the cost estimating software developer must either create an exporter plug-in for each of the 3D modeling systems or it must use a neutral exchange standard such as IFC to import the data. This approach does not bind the designers to any specific 3D modeling software.

On this project, both options were explored for each designer. After some experimentation, the solution for linking the design models to a cost estimating system was working at various levels of success as follows:

- Architectural and Structural: Modeled in Revit and successfully linked using Innovaya Visual Estimating and Timberline Estimating System for the Architectural and Structural scopes of work.
- Fire Protection: No compatible model-based estimating tool was currently available to integrate with AutoSprink, which was the software used for modeling. Manual cost estimates were required. The sprinkler subcontractor had been basing their cost estimates on the number of sprinkler heads rather than the quantities of pipes, fittings, and so forth and had no historical unit costs for these more detailed quantities.
- Electrical: Model-based estimating was not integrated. Even though the model was created in AutoCAD MEP, Innovaya could not be used for estimating because the relevant cost database was not in Timberline or MC2. The other problem was that accurate quantities could not be extracted from the model. The resulting approach was to do a manual takeoff process and to compare to the quantities from the model to ensure that there were no obvious errors.
- Mechanical and Plumbing: CADEst was the preferred model-based estimating tool for CAD Duct and CAD Pipe as they were developed by the same company. However, the Mechanical/Plumbing trade contractors would need to replace their existing estimating software (QuickPen, Accubid) with CADEst to make it work on this project. This was considered too costly and disruptive to achieve in a short time. As a result, quantities from the model were manually calculated and input to QuickPen or Accubid to generate the cost estimate.

### **DPR Model-Based Cost Estimating Solution for Its Self-Perform Work**

DPR has tried and tested Innovaya Visual Estimating<sup>4</sup> which has proven to work very well for its self-perform scope of work (drywall, concrete, doors/frames/hardware). This work represents about 15 percent of the total project cost. Innovaya currently works with AutoCAD and Revit as the modeling software. It links to either Timberline or MC2 for the estimating software. DPR uses both Revit and Timberline, and therefore, Innovaya suited its needs on this project. About 86 percent of the quantities needed for estimating cost came from the Revit model. See Figure 9–3–26.

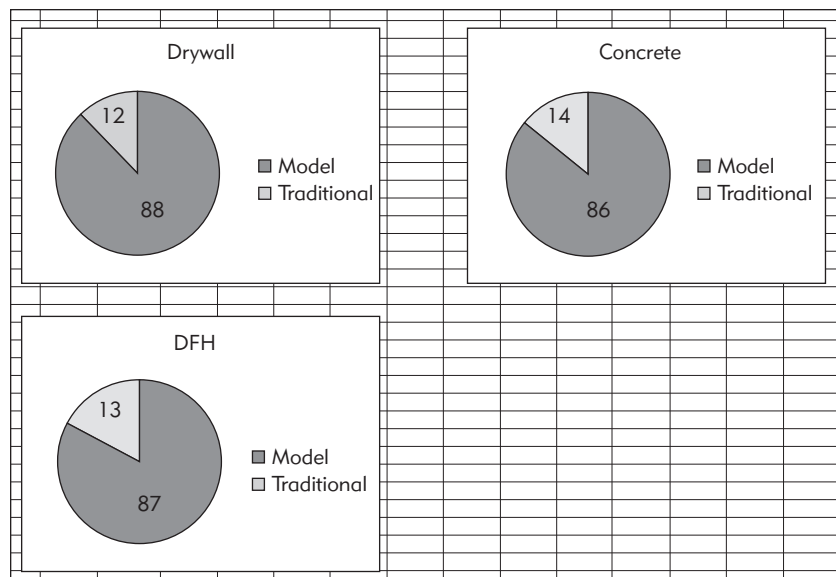
Traditional quantity takeoff (roughly 14 percent of costs for the DPR self-perform work) was required for one of the following reasons:

- Element is not in the 3D model, e.g., temporary shoring, scaffolding.
- The object in the model cannot be used to calculate a needed quantity, such as the number of construction joints; cannot be calculated from any property of the slab on grade, e.g., perimeter length or area, because it depends on how the slab on grade is broken down into different pours.
- Model is not intelligent enough to give a desired quantity, e.g., the length of a concrete wall against a slab on grade will provide the length of

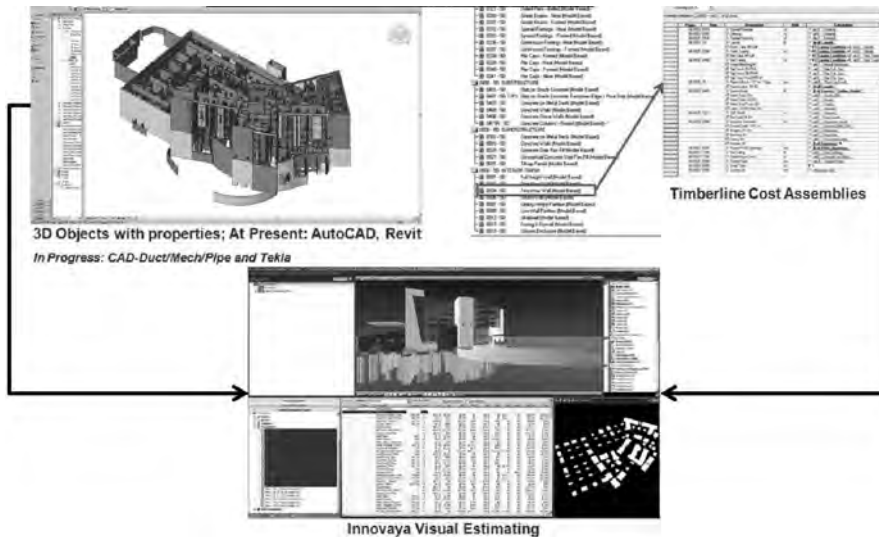
**FIGURE 9–3–26**

DPR self-perform work. Each pie chart shows the approximate percentage of quantities coming from the model or requiring manual takeoff.

Image provided courtesy of Sutter Health.



<sup>4</sup>[www.aecbytes.com/buildingthefuture/2006/VisualEstimating.html](http://www.aecbytes.com/buildingthefuture/2006/VisualEstimating.html)

**FIGURE 9-3-27**

The process of model-based cost estimating using Innovaya to integrate AutoCAD or Revit model with the Timberline estimating system.

Image provided courtesy of Sutter Health.

the expansion joint, but currently this information cannot be quantified from the model because it does not know there is a wall adjacent to the slab on grade.

- When cost is a function of time and not the 3D element, e.g., construction trailers, temporary power, equipment, and so forth, workers are dependent on the duration of multiple construction activities and the project as a whole.

### ***Collaboration between Design Team and Builders to Make Model-Based Estimating a Reality***

At SMCCV, the model-based cost estimating process involved early and intense collaboration among the following:

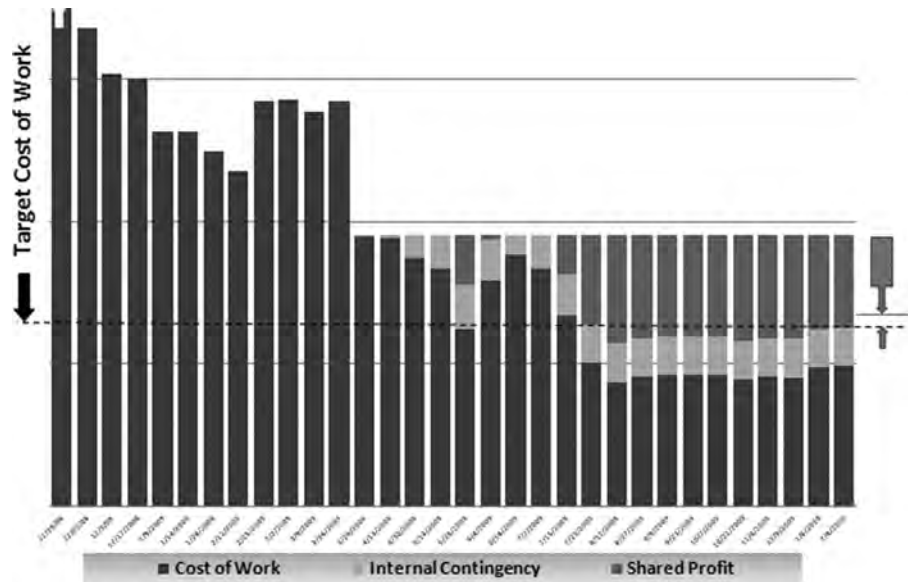
- Architects and structural engineers, who were developing the model
- DPR self-perform work estimators, who have estimating knowledge and a cost database for their self-performed work
- DPR virtual building group BIM engineers, who are experienced in both areas and know how to integrate the two

Sharing a common pool of loss/gain provided a shared incentive to participate in this process. Since the goal was to accomplish the target cost and thereby ensure that the common profit pool was preserved for all IFOA members, Figure 9-3-28 shows how the team was able to drive down project cost during the design process. The early cost estimates at the end of 2008 were

**FIGURE 9-3-28**

Graph of estimated cost over time in effort to meet target estimate and to secure fully funded IFOA profit. The shaded arrow shows how much cost plus contingency needs to be reduced to fully meet the target profit for the IFOA members.

Image provided courtesy of Sutter Health.



considerably over budget but were reduced over time so that by mid-2009 the estimated cost was under the target. Continual effort reduced the cost further so that by February 4, 2010, not only had the target cost been achieved, but there was no provision for internal (IFOA member) contingency and almost the full projected profit. The shaded arrow shows how much cost plus contingency needs to be reduced to fully meet the target profit for the IFOA members.

Clearly the IPD process that achieved these results had been successful. It is likely that the intense collaboration allowed each firm to eliminate contingencies that had been included in earlier cost estimates because of better understanding of the project and a clean clash-free design that would be efficient to construct.

Figure 9-3-29 shows what costs were committed (to be spent or already spent) as of February 4, 2010. These costs are shown by cluster:

CIV—Civil

ENV—Envelope

MEP—Mechanical, Electrical, Plumbing

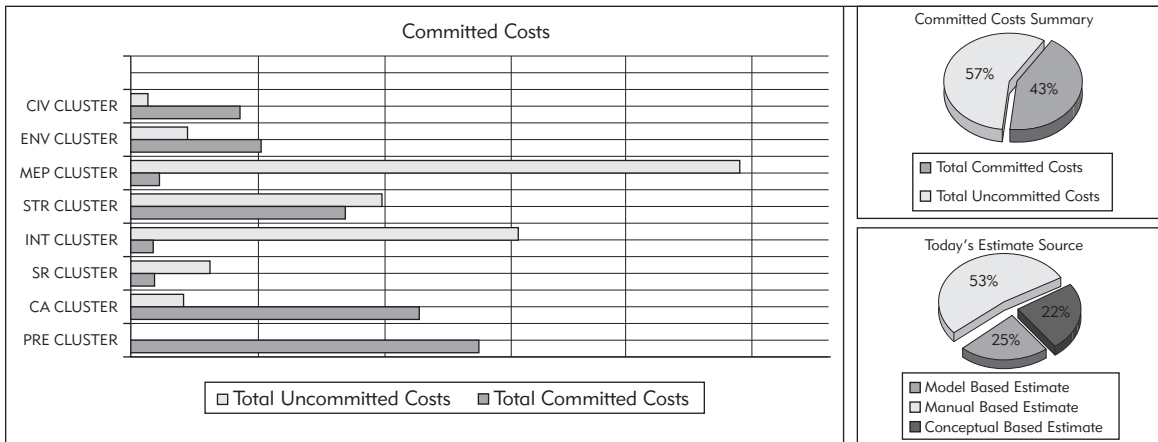
STR—Structural

CA—Construction administration and site related

INT—Interior

SR—Site requirements: clean-up, trailer rental, trucks, and the like

PRE—Everything relating to preconstruction activities, including design and buy-out



**FIGURE 9-3-29** Graph of committed cost by cluster and sources of the target cost estimate.

Image provided courtesy of Sutter Health.

The diagram in Figure 9-3-29 shows that at this point in the job, 57 percent of the costs had been committed.

The lower right-hand pie chart shows the sources of the estimated target cost: 53 percent from manual takeoff, 25 percent from the model, and 22 percent from the conceptual estimate that was prepared from the conceptual design. Clearly, the target estimate required a significant amount of manual effort despite the fact that a great deal of effort was expended to allow the use of the model.

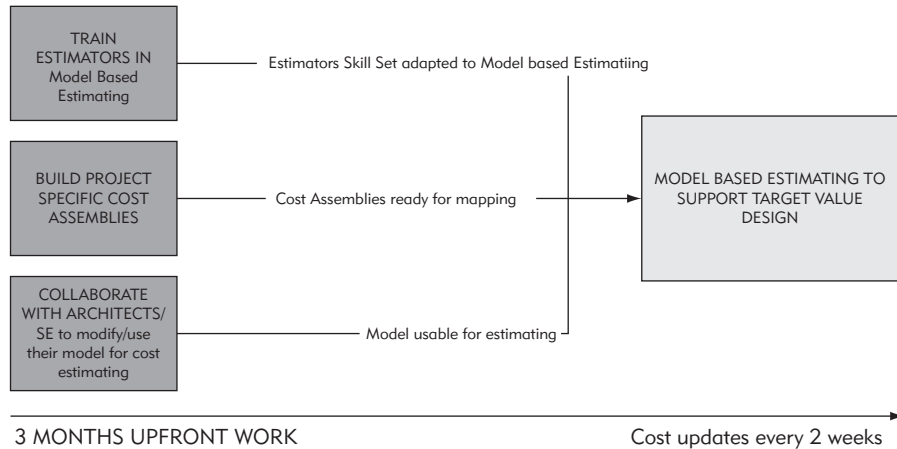
It took approximately three months of setup time for the cross-functional team of the architects, engineers, self-perform work estimators, and BIM engineers to automate the cost-estimating process and generate biweekly cost estimate updates after design changes. This is outlined in Figure 9-3-30. It required only one estimator in each self-perform work group just two days to generate an updated model-based cost for each two-week cost-estimating cycle.

To prepare for model-based estimating, the first step was for DPR to identify design objects that were modeled incorrectly for estimating purposes (either the quantities were inaccurately modeled or the elements were not broken down the way they would be constructed). This list of problems was provided to the architects and structural engineers who then made changes to the model over the span of two months. This also included some parameters that needed to be added to the objects to automate the mapping process with the

**FIGURE 9-3-30**

Upfront work to automate cost estimating process.

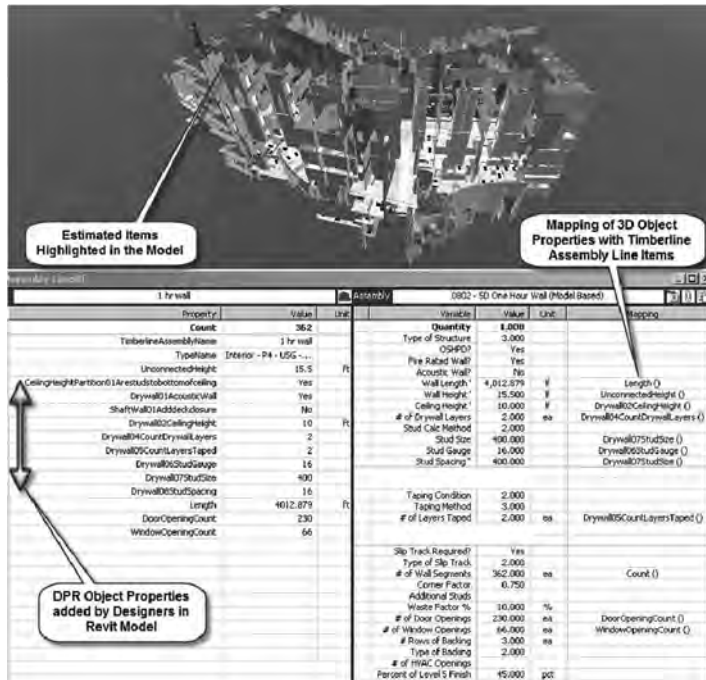
Image provided courtesy of Sutter Health.



**FIGURE 9-3-31**

Matching object parameters in Revit to cost assemblies in Timberline (using Innovaya).

Image provided courtesy of Sutter Health.



cost assemblies due to the limitations of the modeling software (Revit). For example, to quantify the wall surface area that was required for finish sheet-rock taping, the ceiling height was added as a shared parameter to a wall object in Revit. In addition, existing cost assemblies in Timberline were modified so that they could be mapped with the 3D model objects in Revit. Figure 9-3-31



shows the 3D model object with the DPR object parameters fed in on the left side and the cost assembly created in Timberline on the right side.

Once the cost assemblies and 3D model objects were able to be mapped, then the cost was generated using the mapping process. The next step compared the cost with the traditional estimate to see if they were comparable. Transitioning a traditional estimate to a model-based estimate was a cumbersome process, because it was sometimes hard to resolve the quantity and cost variations if the quantities using the traditional takeoff were not recorded.

After these two steps had been completed, it was necessary to train the estimators in the model-based estimating tool. The time it took for an estimator to get comfortable with the model-based estimating software varied from one to two months. Once this training was complete, cost estimates could be generated once every two weeks.

### ***Challenges of Implementing Model-Based Cost Estimating***

The challenges of model-based estimating go beyond finding appropriate software solutions. The transition from manual estimating to a model-based estimating process takes substantial effort, time, and cost. The experience on this project was that it was relatively easy to purchase the new programs and transfer the estimating database from one source to another. The difficult part was the cultural shift and training required. Estimators must be thoroughly trained in the new software and run test cases before they can have confidence that the information coming out of the model is accurate. At first, the model-based estimating process may also take more time than the traditional approach. However, after time and with greater proficiency in using the software, the model-based approach should take less time and provide excellent accuracy. This was the experience on this project.

Another issue is the question of who will pay for the transition from one software system to another. Should it be the owner of the project interested in adopting model-based estimating or should it be the trade contractor who will derive benefits from its use on this and future projects?

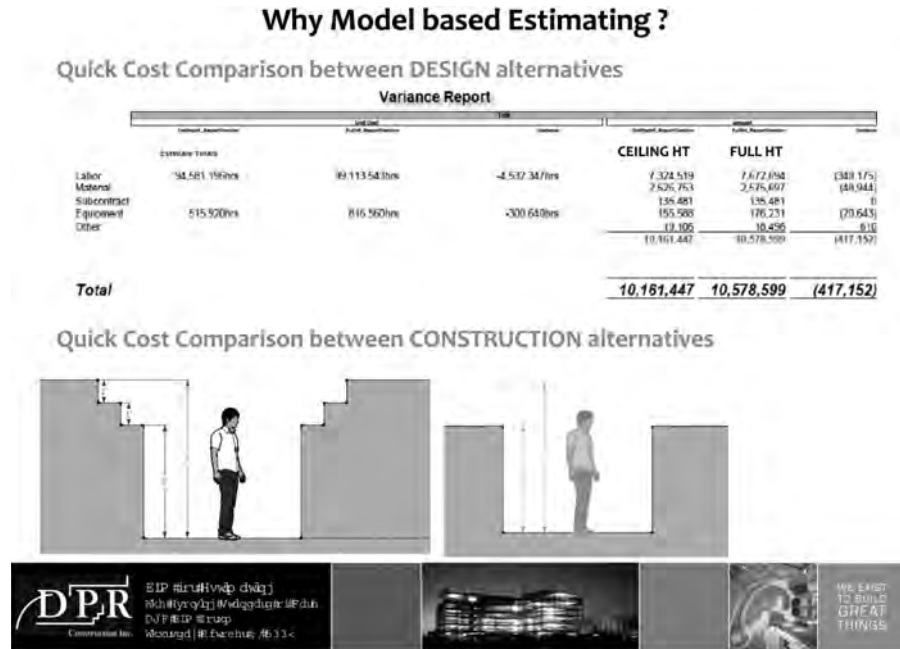
### ***Benefits of Model-Based Cost Estimating***

The model-based cost estimating process was implemented on the project so the team could rapidly understand the cost impact of the design decisions. As the DPR and DGL team was trying to figure out how to get parameters in the models to support the model-based estimating process, the team decided to use quantities from the model as a proxy for cost. The quantity trend from the model was generated every week and tracked so as to see how the design was evolving. The quantity trending process is shown in Figure 9-3-32. This process also

**FIGURE 9-3-32**

Cost comparison of design/  
construction alternatives.

Image provided courtesy of  
Sutter Health.



helped to evaluate the cost of design and construction alternatives with quantity trends for selected model objects. Figure 9-3-32 shows examples for both.

### **Lessons Learned from Model-Based Cost Estimating**

On this project DPR Construction has taken model-based cost estimating to the maximum practical extent. As a result, there have been a number of lessons learned, some of which are related to the process and organization and others are software related. The following are examples of both areas.

- Senior company management buy-in of model-based cost estimating
  - If the senior company management sees the value in the model-based cost estimating process and endorses it, it is much easier to implement within the company. Some of the trades were resistant to move away from traditional estimating practices and hence continued to use manual cost estimates as long as they were able to still meet time constraints.
- Contractual language of the project to support collaborative work environment

Because this is an IPD project, it has been easier to work with designers who would entertain requests for model modifications because of the IFOA contract which encourages a collaborative work environment and goal alignment by providing incentives, such as a common pool of profit.

- Not all cost estimates can be based on the model.

Some of the items in the estimate cannot be quantified or formulated from the existing 3D elements in the model. Items such as construction joints in slabs are means and method items, which need to be manually quantified. Also, there are time-based cost elements such as man lifts, temporary power, trailers, and so forth, whose costs relate to how long they are on the jobsite, which cannot be quantified from the 3D model.

- Transitioning traditional estimates to model-based estimates

A visual record in the form of marked up drawings of what was a part of the hand takeoff is important to have so that quantities can be compared easily with the model quantities. This was significant during the transition from manual to model-based quantity takeoff.

- A new software tool does not always perform as expected.

Implementing new technology is not always successful the first time. A lot of collaboration with the software developer may be required before the desired results are obtained.

- Model-based cost estimating is not an automatic process.

There is a lot of prerequisite work in preparing the cost assemblies, preparing the model, training the estimators, and so forth. All of these steps are required to make this process work successfully.

- Start the process early—no later than the end of the conceptual design phase.

The earlier the teams start doing model-based estimating during the preconstruction phase, the more useful the model will be for cost estimating. This will allow more time for the design team to determine which design alternatives are best able to meet the target estimate.

- Work collaboratively from the beginning.

Architects and structural engineers, who build the design models, need to work collaboratively with the contractors to understand how their models will be used for cost estimating and, thereby provide the proper input to the 3D model.

### 9.3.6 Meeting Sustainability Goals

The Environmental Stewardship goal of the owner was to achieve (as one option) the LEED Silver v2.2 requirements (see Goal 5b in Table 9–3–2). This involves getting a total of 33 to 38 points (out of a maximum of 69) on the LEED Checklist 5. This required both design and construction modifications as shown in Table 9–3–7. Meeting these goals required a continuous consciousness of sustainability issues during the design and construction process.

**Table 9–3–7** Examples of Design and Construction Modifications to Meet Sustainability Goals

---

**Site Suggestions**

The current plan is to demolish the existing Eden Medical Center in 2013 after Sutter Medical Center, Castro Valley is commissioned. Rather than off-hauling and land-filling the hospital debris, the plan is to demolish the hospital into the footprint of its basement and then use this as a fill material for the planned surface parking lot. There are clear economic benefits for not off-hauling this material. In addition, it will reduce trucking emissions and landfill space.

**Design Modifications**

Use highly efficient water closets to reduce water use.

Use highly efficient glazing to reduce solar heat gain and cooling requirements.

Put a garden on the roof to reduce solar reflectivity coming off the roof which helps to temper the urban heat island effect.

**Construction Modifications**

DPR will coordinate all equipment to reduce the need for each trade contractor to use separate equipment. This will increase the efficiency of material movement and reduce the number of units needed on the site and hence the carbon footprint generated by equipment use. To accomplish this, the relevant IFOA team members have credited their "equipment" line items to DPR which has incorporated the funds into its project planning, worker power, and equipment budget. All eventual savings will be shared with the IFOA members via the shared profit pool.

In addition, Morrow-Meadows, JW McClenahan, and DPR have all contracted with the same underground utility contractor to limit the amount of overlapping machinery onsite.

The same logic has been applied to waste management and shared trades (such as firestopping at penetrations, debris cleanup, and so forth). By optimized single-sourcing of these types of activities, the environmental disruption inherent in the construction process is minimized and costs are reduced.

A carbon footprint reduction plan has been established for the administrative and labor forces which highlights carpooling opportunities, public transportation availability, and bicycle routes to the site.

---

To ensure that these project goals are met, DPR and Devenney assigned LEED accredited professionals to their teams at the project site.

**9.3.7 Lessons Learned**

- IPD requires a shared commitment to the owner's goals.

On this project there were 11 members that signed the Integrated Form of Agreement (IFOA) and were equal partners sharing the profit and/or loss. This helped to align their goals and optimize total project results rather than those of the individual firms. It also provided a basis for trust among the IPD team members.

- Owner leadership

This starts with an IPD contract that clearly spells out the goals and methods that will be used to achieve these goals. It requires continuous leadership by the owner and project manager to ensure that the IPD team stays on track and that decisions are made that represent the owner's interests. The PM needs to provide the team members the freedom to come up with innovative solutions to the many challenges that arise during the project delivery process.

- Colocation of project team

To promote collaboration and trust among team members, it is vital to have key team members collocate at a project site "Big Room" where they can meet face-to-face to share all current information about the project (3D model, cost estimates, problems, and so forth) and build an effective team. This does not mean that all members of a team need to be at this location, but senior managers and key designers and builders are needed. Online access to a continually updated base of project information is required for all team members, regardless of location.

- Continuous collaboration of team members to achieve a deep understanding of what others need

The use of process mapping (visual mapping of all design functions) required continuous discussions among team members to really understand what was needed to meet OSHPD submittal requirements. This was a significant departure from traditional practice where teams work in independent silos and then review completed documents.

- Planning and replanning

Both are fundamental skills for any IPD project team and require investment in time and resources. These skills are critical to ensure proper alignment of work expectations. Careful planning of the design tasks and the team's ability to identify the last responsible moment to release work for production allowed the design to evolve with as little rework as possible. This allowed the team to produce a highly coordinated design using less time and resources than they would have been able to produce otherwise.

- Sharing of 3D models as the basis for design collaboration

All IPD team members did their design using BIM creation tools that were supported by the ProjectWise file servers. This provided continuous access to the current status of the design and avoided problems of using out-of-date drawings. Designers and builders could share in-process designs and work out constructability problems as the design progressed rather than waiting until a design had been completed. Thus, the shared

3D model became the basis for all design decisions rather than waiting until clash detection was used to find hard and clearance clashes.

- There are no *minor* design changes

Small design changes that one team might consider minor can cause significant problems (space conflicts or constructability issues) for other disciplines. Rather than wait for a design to be completed before checking with other team members, options are explored early and the solutions with the least cross-discipline impact are selected for further refinement.

- Do not wait too long before bringing the non-IFOA vendors into the design process.

There are many vendors that provide goods and services to the project, but are not part of the top 11 IFOA members. These vendors have traditional lump-sum contracts and are normally not participants in the 3D modeling efforts. A good example would be the rebar and steel contracts. These vendors should be hired early enough to allow them to participate in the modeling process (which might be their preference) so that clashes can be eliminated and their particular field knowledge can be reflected in the design. A better alternative might be to include the significant vendors such as steel and rebar as IFOA members.

- Target costing

Repetitive cost estimates of the in-progress design provided the feedback to the project team that allowed them to align their assumptions and gain trust that the design can be built for the estimated amount. This reduced the risk to each team member and hence the contingencies in the estimated cost. This led to a significant reduction in estimated cost. While it was not easy to achieve an accurate and fast integrated cost estimating process for all team members, the shared commitment of the team together with excellent technical support helped make this possible.

- Early involvement of builders in the design process

The early involvement of the builders allowed constructability issues to be considered during conceptual design rather than after the design concepts had been developed. Builders include not only project management, but also superintendents and foremen who will actually build the facility. This produced a cleaner and more cost-effective design.

- Make maximum use of prefabricated assemblies

Throughout the design process, consider off-site prefabrication as an alternative to the use of on-site labor and materials. This helped to simplify and speed the construction process, reduced the need for onsite storage and increased field labor productivity. Early analysis of prefabrication options allowed greater use of assemblies.

The most important lesson learned from this project is that this team is looking at IPD as an opportunity to achieve significant return on investment to all team members and supported by an owner that is willing to fundamentally change how their projects are designed and delivered. It is not enough to simply sign the contract and assume everything will work out to produce the expected final results. There are so many ingrained practices in the information flows from design to detailing to fabrication to construction that are based on years of the industry operating in silos that are fundamentally at odds with achieving the deep collaboration needed for IPD to work. The IPD contract (in this case the IFOA) creates the environment for change to happen, but it is up to each team to take advantage of that opportunity. This requires that they understand deeply how they used to operate in the past and identify the limitations and the waste involved in that method of operation. The next step is to identify and implement new ways to deliver value and eliminate waste through increased collaboration, different ways of using technology, and new methods for planning the design and construction processes. How far a team can take this will depend to a large extent on how high they set their objectives at the start of this process.

### 9.3.8 Conclusion

This is a ground-breaking project, one of the first to show that IPD is not just a utopian vision but a practical reality that can actually be implemented on a complex project. As of the time of writing this case study, it is a very successful project that started with a clear vision from the owner and excellent support from the project team. There was a genuine collaboration effort that was able to overcome lack of experience in using 3D models and lean production planning. Not every participant had the skills, resources, and experience to fully participate in the goals of the project. As in most projects, it took some time before the project team learned how to effectively collaborate and use new tools. The significant changes in the approach used for design were not easy to learn (continuous collaboration, short interval planning as opposed to relative long tasks done independently). But as the IPD team became used to working together in the Big Room at the project site, they became more understanding of each others' requirements and more skilled at effective collaboration and planning. For many team members this was the most collaborative project they had ever participated in, and interviews with team leaders showed that they hoped for similar experiences on future projects. The results thus far are that no milestone has been missed, the project started construction six months earlier than a conventional design-bid-build approach, and the estimated cost is under the target budget.

## Acknowledgments

The authors are indebted to Digby Christian, the project manager for Sutter, for his assistance in providing access to the project team and participation in writing this case study. The access included online and personal interviews, access to all project participants and presentation materials (some of which are used in this case study). The authors are also indebted to Samir Emdanat of Ghafari Associates and Atul Khanzode of DPR, Inc., who also participated in writing this case study. Finally, we are indebted to all the senior members of the IPD team who responded to a lengthy questionnaire regarding their experience on this project as well as interviews with one of the authors.

### 9.4 MARYLAND GENERAL HOSPITAL

#### *Using BIM to Set Up an Effective Facility Management Process During the Construction and Turnover Phases*

##### 9.4.0 Introduction

This case study demonstrates the use of BIM along with mobile technologies during the final closeout stage of a hospital project. The project also shows how BIM can be effectively used to set up an efficient facilities management process.

The project goal was to add approximately 9,600 square meters of space to the Maryland General Hospital (MGH) in Baltimore, Maryland. MGH, founded in 1881, is part of the University of Maryland Medical System. The expansion, completed in March 2010, was connected to the existing structure (built in the 1950s) and included 8 new operating suites, 4 specialty rooms, an 18-bed intensive-care unit (ICU), a pharmacy, and a laboratory. The fact that the hospital building was to remain functional throughout the expansion posed a number of challenges during the construction phase.

The addition in-filled an existing courtyard six stories and continued across a portion of the existing two-story hospital, maintaining a total of six stories (see Figure 9-4-1). In order to effectively provide structural support and comply with the tight schedule, the expansion was broken into two phases starting from the top down. The first phase included all of the structural steel for the addition and complete enclosure of the third floor above the existing



**FIGURE 9-4-1**

A rendering and a photograph of the new Maryland General Hospital, showing the old (back left) and new buildings.

Images courtesy of Corinne Ambler and Barton Malow Company.

building, and the fourth through sixth floors. The second phase included the enclosure and fit-out of the basement through the third floor in the courtyard infill.

The client had not mandated BIM during the design stage and the architect had not provided a model to the contractor. The model was only created once the project manager, Barton Malow Company, saw an opportunity to use BIM during the execution and decided to integrate models from various specialist subcontractors to create a partial model of the building. The model was initially used for clash checking and then subsequently for tracking the closeout process, to capture field data including documentation about equipment, and it was eventually handed over to the client for facilities management.

Barton Malow Company is a construction management corporation whose headquarters is located in Southfield, Michigan. It has a regional office in Baltimore and other regional offices throughout the United States and Mexico. Barton Malow was selected as the construction manager based on their competitive low bid. However, once the contract was executed it evolved into a “Guaranteed Maximum Price (GMP) construction manager at risk” arrangement. All of the work was executed by subcontractors employed through negotiated lump-sum subcontracts.

#### 9.4.1 Why Was BIM Used During Closeout and for Facilities Management?

The general contractor, Barton Malow, had been a steady BIM user with a well-defined strategy to take BIM well beyond its initial and fairly well-established

uses for visualization and clash detection. It was their vision in this project that saw the utilization of BIM during the closeout stage and facilities management (FM).

The new operating suites and intensive-care unit had significantly more MEP systems and much larger ductwork. The project included an extensive array of indoor air handling units, two new 650-ton electric centrifugal chillers, and 650-ton cooling towers, temperature and humidity systems as well as the necessary ductwork, air handlers, dampers, and fans. Therefore, a high level of coordination with management was required to identify the location of the MEP systems and services as well as the conditions of the old facility for structural reinforcement. As the project proceeded, the amount of field-generated data increased. However, there was no central database to save the field information generated, keep an inventory of equipment, and warranty information and optimize the equipment's lifecycle.

Normally at the end of a project, all the as-built information is sorted and archived in boxes which are then handed over to the client. However, as the information is mostly recorded on paper, this resource is hardly ever used or synchronized with a client's facilities management system. With BIM there is an opportunity to link FM-related information with the building model. This can help better visualize the FM process and improve the response times in case of maintenance calls. The current process at Maryland General Hospital had similar shortcomings, the key issues being:

- The lifecycle of the equipment was not optimized.
- Warranty and other product-related information were not easily accessible.
- No ready inventory of equipment was available.

The resulting processes are quite informal and dependent on knowledge gathered by experienced staff members about the facility's operations over the years. As a result, the hospital ends up spending considerable resources on FM but does not get the results it needs. The BIM-enabled process for recording and delivering as-built information offered an opportunity to record and provide accurate as-built information, in a form which helps maintain and manage the facilities in an efficient way and increase the lifecycle of the building.

To make the process more effective and productive, diminish risk, and help the hospital with its future operation and maintenance activities, the construction team decided to create a centralized database. The construction team met with the owner to discuss the issues of the project, but most importantly to find agreement between the hospital, the construction team, and the project

team on the procedures to be implemented. According to Barton Malow, the main objective in implementing BIM for closeout and facility maintenance was to “create a central database containing closeout documentation and maintenance of information that can be easily accessed in the field, and easily maintained and linked to a 3D model for better visualization.”

### 9.4.2 Building Information Systems

The original project documents did not specify any BIM requirements. During the design phase, the design team did not use BIM, and the design was prepared using 2D drawings. The team used the paper blueprints of the original structure to a certain extent and adapted its schemes to the information from site investigations done as the construction work progressed and areas and walls were opened. The construction team had to match existing deck to deck dimensions from the existing spaces. The floors had to line up when the team broke through the existing hospital exterior wall into the new added spaces. Additionally, the new added spaces had significantly more MEP systems than the existing spaces. To properly install all the new MEP systems, the team required a high level of coordination with the management department to identify location of the existing MEP systems and services. In order to increase coordination, and make it more efficient, the mechanical contractor suggested the creation of a building information model.

#### *Modeling MEP Systems*

The building model was compiled for the mechanical and electrical systems using MAP Software’s CAD Duct and CAD Electrical software. CAD Duct generated drawing files that were opened directly with CAD Duct manufacturing modules, which allowed the contractor to directly load the information and then overlay it with the HVAC fittings. Since the model was 3D, it checked collisions and conflicts, generated reports for purchasing, annotated sizes, elevations, and part numbers. All elements on the model were assigned the barcode number generated with the hospital to enable the information pertaining to the MEP parts be linked to the centralized database. CAD Electrical allowed the contractor to design and modify electrical control systems. CAD Electrical assigned wire numbers and component tags to the drawings. It generated reports such as bills of materials, cable lists, and terminal reports from/to wire lists, among others.

In addition to coordination, the model was also used by the sheet metal contractor for prefabrication of sheet metal. However, the model had only the MEP data. As the project proceeded, the amount of information describing the other aspects of the building increased, but it was not in electronic format.

### ***BIM for Closeout and Facility Maintenance***

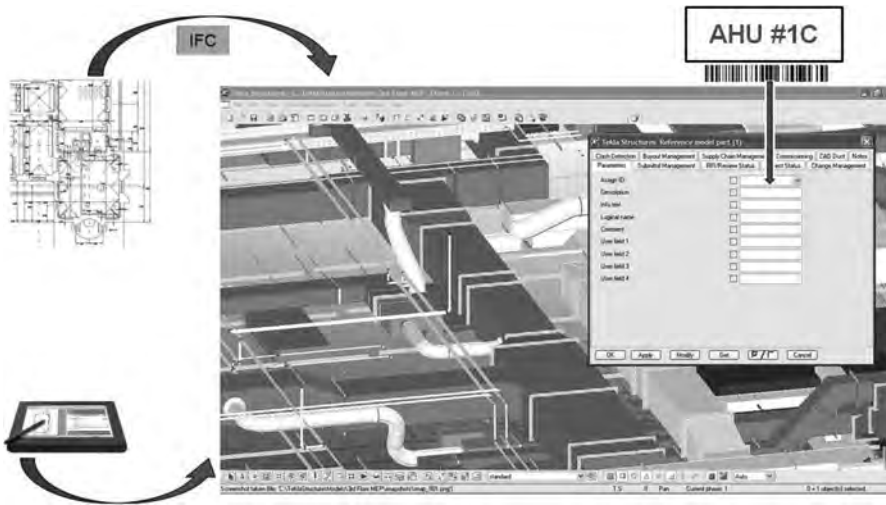
On the initiative of Barton Malow, the decision was made to compile a comprehensive building information modeling system that would support the closeout and subsequent facility management activities by integrating the MEP models, the structural data being collected onsite, and the data describing the equipment and its status. This required introduction of a central building modeling platform and a Computerized Maintenance Management System (CMMS). The BIM platform selected was Tekla Structures for Construction Management. The selected CMMS system, Tiscor ([www.tiscor.com/](http://www.tiscor.com/)), was already being used by the client.

Tekla Structures for Construction Management software (Tekla, for short) manages project information contained within a database, including structural, architectural, HVAC, and MEP systems. The database stores 3D objects that also carry information such as cost, material procurement, time scheduling, and any additional project management information that is needed. The process within Tekla structures is to integrate the project information with individual discipline-specific models to create a combined project model. Strictly speaking, Tekla Structures for Construction Management is a model integration solution and not a model authoring solution. No physical objects are created in this version of Tekla, although they can be generated using the full version of Tekla Structures. Models created using any BIM solution can be imported to Tekla, which coordinates the model with all the objects and areas, performs clash detections and resaves the model in the new condition after subsequent coordination clash checks.

Although no building information model was produced during the early stages of the project, the steel contractor had hired a company called Cadtech ([www.cadtechonline.com](http://www.cadtechonline.com)) to produce a model for their own use. This model alone formed the backbone of the structural model, which provided the building geometry in Tekla. The models created in CAD Duct and in CAD Electrical were imported to Tekla using Industry Foundation Classes (IFC) (see Figure 9-4-2). This file format facilitated interoperability between the CAD models and Tekla, allowing import of all the MEP systems information generated by the mechanical contractor. In addition, specialized systems such as medical, gas, and others were modeled and added to the database.

### ***Facilities Management Database***

The Tiscor CMMS software package manages information about the maintenance operations and schedules maintenance activities. A CMMS improves uptime, establishes preventive maintenance, organizes work orders, helps management make informed decisions, and provides data for third-party

**FIGURE 9-4-2**

Input of model and field data to the Tekla model.

Image courtesy of Corinne Ambler and Barton Malow Company.

applications. The Tiscor software monitors safety, performance, preventive maintenance inspections, and scheduled parts replacement. It also compiles vendor work orders, schedules work orders, creates work orders for every piece of equipment, provides safety committee and compliance reports, and produces reports in various formats. All of the relevant project data was incorporated in the Tiscor system, since an efficient facilities management operation requires complete and accurate data of the asset. This data included all the data gathered during the construction phase of the project and throughout the lifecycle of the hospital.

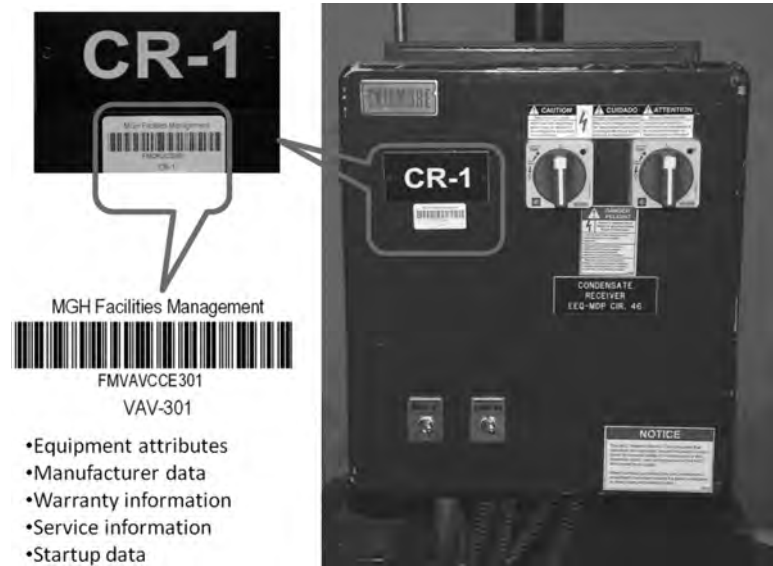
### **Field Database Access**

The information system was intended to make the closeout of the project, the commissioning phase, and the facility management process more efficient. All of these require that engineers, inspectors, and maintenance personnel have access to all the information in the field. The link between physical equipment and their virtual representations in the 3D building information model and the centralized database was established using barcodes and specialized software on tablet PCs. Each piece of equipment was tagged with a unique barcode in an accessible location.

A software called Bartender was used for generating the barcodes using Code 39 Standard Barcode Symbology. All barcodes were 11 characters long and were the same as the Maryland General Hospital's internal control numbers. The barcoding algorithm identified various attributes of the equipment, including Type, Equipment, Location, and sequence Number (see Figure 9-4-3).

**FIGURE 9-4-3**

Barcode format, adapted from BIM facilities management integration, Maryland General Hospital—Central Care expansion presentation slides, March 2010.



For instance, barcode FM-CRU-ENT-001 referred to facility management, control rate unit, located in the entrance, and number 001.

The Bartender software recorded the Equipment Name, Equipment ID (which was exported from Tekla), and the barcode itself. Once all the barcodes were generated and printed, the barcode database was exported to an MS Excel spreadsheet, which was in turn used to synchronize the barcodes with Vela Systems field software and hence with the Tekla model.

Information from the field was gathered and updated with Vela Systems software. Data generated in the field (inspection results, commissioning data, and so forth) was input and updated by the field personnel with the use of the tablet PC software developed by Vela Systems. Similarly, information from the centralized database could be easily accessed in the field. Figure 9-4-4 illustrates the setup. Vela software can work in offline mode while capturing project information in the field, which can then be synchronized with the central database when in the office.

The barcode identities were the point of integration of all the information. Field-generated data gathered with Vela was updated online into the Tekla model. Folder hierarchies were set up in Vela Sync Folder, with a folder for each piece of equipment. After each piece of equipment was identified through the barcodes, the electronic files that were related to it were added to its folder. Next, the integration adaptor between Vela/Tekla was run to create an .xml file



**FIGURE 9-4-4**  
BIM and facilities management integration. Input of model and field data to the Tekla model and the CMMS using barcode identities.

and finally the .xml file was imported into Tekla. In this way, the hospital had all the closeout documentation in electronic format.

From the Tekla model, the updated information was then referenced to the facility management information through the barcode IDs and used to support asset management operations with Tiscor.

The tablet PCs were supplied by Motion Computing, which specializes in rugged devices. They are waterproof and weigh around 1.5 kgs (3.3 lbs). They have an integrated RFID and barcode scanner on two front corners. They also have a camera and a voice recorder built in. The computers are fully featured systems running the Microsoft Windows Vista operating system, and are operated using the touch screen and a stylus.

### 9.4.3 Construction, Closeout, and Commissioning

Although, the construction process had already begun when the tablet PC was first introduced to the personnel, it facilitated and greatly benefited the construction process. The tablet PC enabled field personnel to record data once, share information with the entire team, and access construction documents such as drawings, models, product data, and specifications in the field. Additionally, it enabled documentation of safety, update of delivery information, generating punch lists, and logging, tracking, documenting, and communication of issues in the field immediately.

The tablet PCs made the BIM model useful in the field for construction as data was available at any time for the construction team. The team scheduled activities and also visualized progress and status in Vela software. The software also enabled construction quality programs, connected BIM to closeout documentation, and improved field productivity and accelerated project schedules.

All the information from the field gathered with the tablet PC was joined to the BIM model for commissioning. The BIM solution used the tablet PC to generate inspections/tests, associate data with objects in the model, and enable all parties to access inspection and test information for commissioning. The four main phases of the equipment installation process that were tracked for commissioning were:

1. Precommissioning: when the equipment is received onsite
2. Functional performance test: equipment is tested to ensure that it functions appropriately
3. System startup: to ensure that all the equipment in the complete system is functioning appropriately
4. Equipment acceptance: client accepts the installation and signs the acceptance form

During the field inspections, all of the data about each piece of equipment—name, location, barcode, model and serial no., manufacturer information—was captured with the help of the handheld computers. As shown in Figure 9–4–5, the handheld computers are fitted with a barcode scanner on one end that is used to scan the tag on the equipment. This then brings up the details about the equipment in the Vela system, where the equipment attributes can be entered.

**FIGURE 9–4–5**

Engineer in the field scanning equipment tags with tablet computer. (See color insert for full color figure.)







**FIGURE 9-4-6**  
Custom tabs in Tekla software for equipment data.

When the engineer returned to the office and docked the tablet PC, the information collected using Vela was synchronized with the Tekla model, and could be viewed in association with the building model entity, as shown in Figure 9-4-6. This helped keep track of the project visually, as at any time a “heat map”—a color-coded representation of the project status—could be produced.

#### 9.4.4 Facility Maintenance Workflows

The traditional facility management operations in MGH used three processes that were inefficient. The first process added or replaced equipment, the second process generated maintenance work orders, and the third process dealt with service calls.

As explained above, the construction team proposed a BIM solution to streamline and eliminate some of the steps of these three processes. The BIM solution was developed to reuse all the information created during construction to support and improve facilities management operations. The process developed was a procedure to capture information and implement the hospital’s dataset into the facility’s management software. The procedure traced information from its delivery by construction through its incorporation into the operations system and finally delivery to MGH.

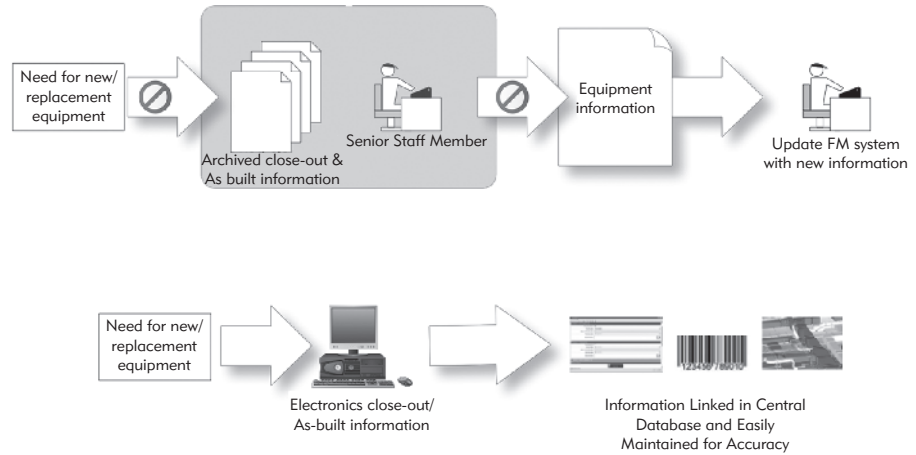
Once completed, these three main facilities management processes used the building information models and the central database system with the handheld devices.

##### ***Addition or Replacement of Equipment***

The process used the existing as-built documents to get information on equipment and take any necessary action in order to keep equipment functioning.

**FIGURE 9-4-7**

The old (top row) and new (bottom row) processes for addition or replacement of equipment. The old process is wasteful and error prone because it requires repeated data entry.

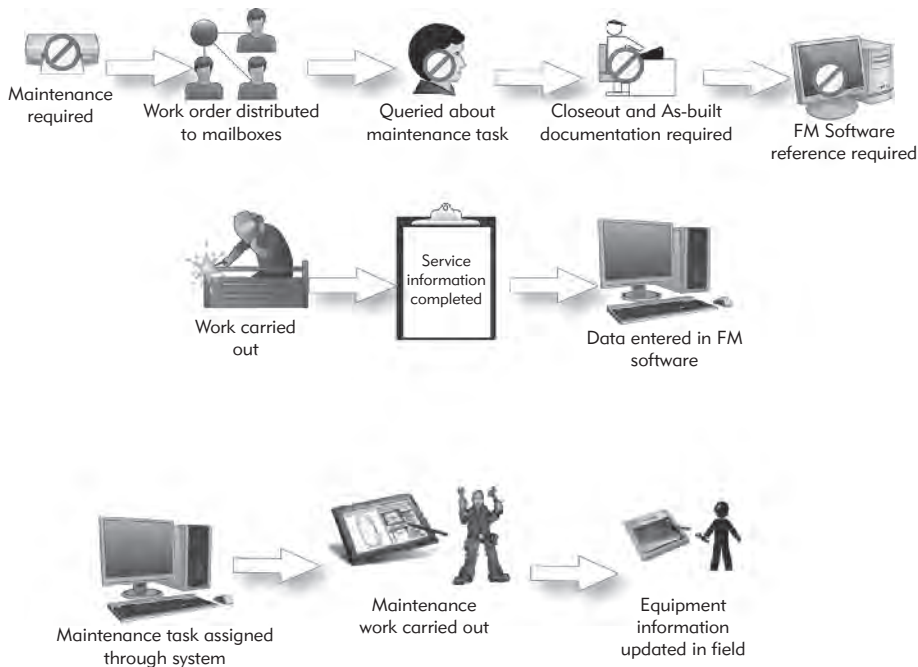


Information was not easily searched since binders could not be found, and the as-built documents were often out of date and needed to be complemented with information only known by the facility management staff. Often, equipment information could not be retrieved because the inventory of equipment was incomplete or misplaced. As a consequence data entry was continuously required in an effort to keep inventory information updated.

With the new system, the field engineer accesses the information in the field while inspecting the equipment, updating the records with new/replacement equipment information. The information is synchronized with the central database when the engineer connects to the network. Figure 9-4-7 illustrates the old and the new processes.

### ***Maintenance Work Orders***

The existing process, illustrated in Figure 9-4-8, did not automatically pre-assign required maintenance since schedules were missing. Maintenance had to be assigned monthly and was not done according to the equipment's real needs. Furthermore, status on repair was unknown and often repair staff performed tasks without knowing if they were needed or not. Work orders were distributed to mail boxes, and issues about operations were difficult to solve since closeout documents were not referenced. In many instances, due to the lack of information, the service technician makes a judgment call that could affect the piece of equipment in the long run. In addition, every time a repair was completed, a paper service form had to be filled out and its data had to be entered in the facility management software.

**FIGURE 9-4-8**

The old (top two rows) and new (bottom row) process for maintenance work orders. The old process not only required more work, it also had a significantly longer cycle time.

The new process, also shown in Figure 9-4-8, allows work orders to be assigned electronically to a service technician. All information needed to complete the work order is available readily. The service survey/checklist is then completed electronically, thus eliminating all data reentry.

### **Service Calls**

During a service call, the key information needed includes the manufacturer's or the supplier's warranty, equipment service contracts, and other related installation and commissioning information. In the existing process, the information was not always readily available either due to missing or misplaced documentation. On many occasions, the service contract-related information was not readily available, with the result that in-house technicians carried out tasks for which the hospital was actually paying a third party. With the new system, all aspects of equipment-related information, including the service contract and manufacturer's contact details, are captured right from the closeout stage and are updated constantly. This makes the system agile and reduces duplicate efforts.

### 9.4.5 Summary, Conclusions, and Lessons Learned

The MGH case study shows how information from different sources was integrated using an innovative approach to manage and compile the data in a systematic way. BIM was used to gather and reorganize the information generated during an extensive hospital construction and rehabilitation project in a centralized database and integrated with facilities management software. The centralized database contained information gathered in the field. The system made data available at all times, helped eliminate waste from facilities management, optimized and increased the lifecycle of equipment, increased efficiency in the preventive maintenance, and provided accurate and electronic as-built documents. Data from multiple sources and software systems was successfully integrated. Information records were linked with physical equipment using barcodes.

In most projects, including many reported in the case studies in this chapter, BIM has been used mainly for design and construction management. There are, however, opportunities to take it further and use it during the whole lifecycle of a building. As this case study shows, there are technologies that can synchronize the model with other critical systems such as a CMMS. It is only a matter of defining new processes and capabilities around the BIM core. The handheld devices that were used during this project, and many other portable computing devices, have been around since the last decade. Also, software systems such as the one provided by Vela also exist and have been used for various other tasks such as punch-list generation and task management in the field. Integration of these tools and systems is not yet very common in the construction industry. With the increasing focus on building performance from the sustainability perspective, especially with zero carbon policies, such systems can enable better management systems and help reduce the waste around the facilities management process. This case study demonstrates that BIM can be effectively utilized to enable an efficient and agile facilities management process.

At the end of the project, Maryland General Hospital acquired two Tekla licenses and the final model with all the closeout information was handed over to the facility maintenance department, together with two tablet PCs which were paid for from the project contingency. This provides the FM team an opportunity to visually assess the situation and access essential information about any installed equipment, such as warranty, service contract, manufacturer data, and so forth.

The success of the implementation of the centralized database and BIM solution for facility management was evaluated accounting for all the costs that MGH invested in the BIM facilities management integration. The overall system costs included approximately \$25,000 for the various software

licenses (Tiscor, Tekla, and Vela); \$10,000 for software customization; and \$6,600 for training. The benefits include increased productivity of the staff of 12 personnel employed in maintenance, reduced waste resulting from a reliable maintenance program, reduced waste of erroneously repairing or replacing equipment covered by warranties or outsourced service contracts, and of course, enhanced level of service of the building's systems to the hospital's core activities. In computing the increased productivity of the maintenance staff, the hospital estimated that the setup costs would be recouped within as little as two to three months. The system also enhances the hospital's ability to meet the strict performance requirements of the Joint Commission for the Accreditation of Healthcare Organizations (JCAHO).

Implementation of BIM may be successful if the parties involved rethink and reorganize the building process, considering not only the value during construction itself, but during the facility's service life as well. Having stakeholders who are open to ideas and willing to participate in an innovative process and adopt new technologies is very important. It can be very difficult to force a change in culture and in the ways people are used to doing things. The hospital and all team members were willing to use these new tools to become more efficient, so that battle did not need to be fought.

Finally, an important lesson learned from this project is that BIM can be implemented and used at any stage, even starting late in a project's lifecycle. Naturally, it is better to start early with a BIM implementation to exploit the full advantage. Barton Malow's project manager noted that "Earlier is always better. We implemented during the last 10 months of the job. If we had implemented sooner, we could have planned a little bit better." Nevertheless, these new tools forced Barton Malow to compile data and documents for closeout early, which in the end was a significant benefit because the contractor was ready to hand this information over sooner to the client.

## Acknowledgments

This case study was researched and compiled by Bhargav Dave, Research Fellow and Ph.D. student at the University of Salford, and Laura Flórez, Ph.D. student at Georgia Tech. The authors are indebted to Corinne Ambler from Barton Malow Company, Andy Dickey of Tekla Corporation, and Josh Kanner of Vela Systems.

## 9.5 CRUSELL BRIDGE

### *A Building Model Supports a Wide Variety of Information, Uses of BIM in the Construction Stage*

#### 9.5.0 Introduction

The Crusell Bridge is a cable-stayed bridge, commissioned by the City of Helsinki's public works department, which connects the western edge of Jätkäsaari with Ruoholahti. Jätkäsaari, a part of the former West Harbor near to the city center of Helsinki, is being transformed into a new maritime urban district. Cargo operations have been moved to another part of the city to make place for development of some 9,000 new dwellings, giving rise to the need for a new road bridge. Figure 9–5–1 shows a rendering of the cable-stayed bridge in its setting in Helsinki harbor.

Construction of the Crusell Bridge project began in the fall of 2008, and completion was scheduled for late 2010. The bridge was designed by WSP Finland and constructed by Skanska Civil. It has two asymmetrical cable-stayed spans, measuring 92.0m and 51.5m (the total length is 143.5m), and has a traffic clearance width of 24.8m. The superstructure of the bridge is composed of longitudinally prestressed concrete beams; the horizontal structure is a composite steel and concrete structure, as illustrated in Figures 9–5–2 and 9–5–3.

#### FIGURE 9–5–1

A rendering of the new Crusell Bridge in Helsinki harbor.

Image courtesy of WSP.



During the design and construction process the project team implemented both BIM technologies and lean construction principles and tools. This case study focuses on the construction stage of the project, highlighting two aspects:

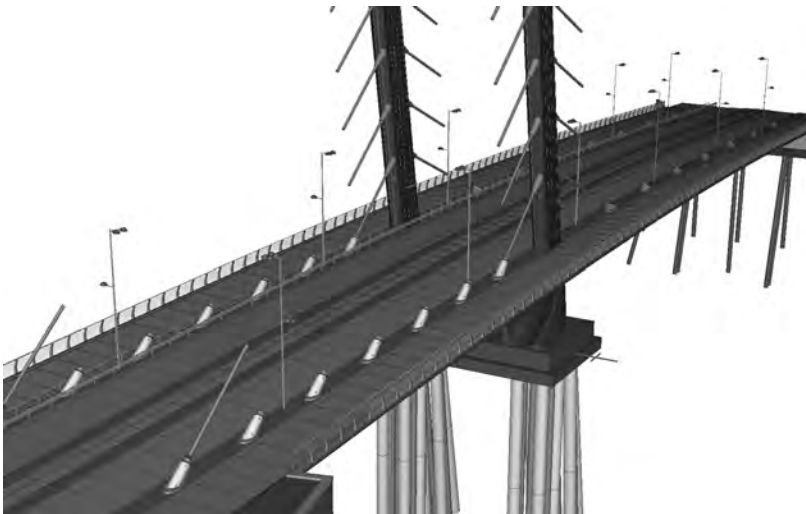
- The extensive use made of the building information model, for fabrication of steel girders and concrete reinforcement, for monitoring and



**FIGURE 9-5-2**

An architectural rendering of the bridge deck at night.

Image courtesy of WSP.



**FIGURE 9-5-3**

A building model of the bridge structure. (See color insert for full color figure.)

Image courtesy of Skanska Finland.

**Table 9–5–1** Crusell Bridge project team and basic data

<b>Client:</b>	City of Helsinki, Public Works Department	<b>Width:</b>	24,8 m
<b>Designer:</b>	WSP Finland Oy (Inc.)	<b>Spans:</b>	92,0m+51,5 m
<b>Main Contractor:</b>	Skanska Civil Oy (Inc.)	<b>Total Length:</b>	173,5 m
<b>Location:</b>	Helsinki, Finland	<b>Schedule:</b>	Autumn 2008–Autumn 2010
<b>Type:</b>	Cable-Stayed Bridge	<b>Cost:</b>	Approx. 15 million Euros

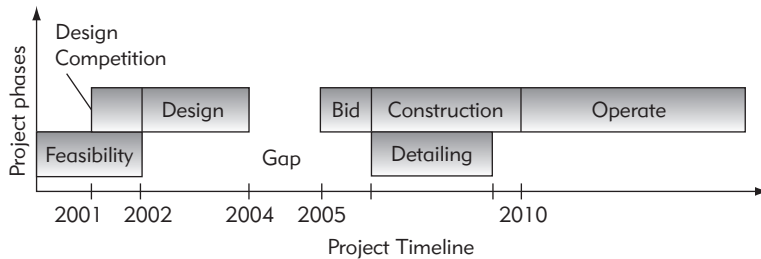
management of the supply chain of fabricated components, for formwork and temporary support structure design, for quality control using laser scanning, and for construction planning using 4D animation.

- The ways in which BIM supported lean construction practices, such as its support of production management onsite using the Last Planner System™.

The design for the Crusell Bridge was solicited by the City of Helsinki in a design competition announced in the winter of 2001. The competition aimed to find a quality bridge solution that would bring out the characteristics of the area and take into account the requirements of the landscape. Although a British design firm won the competition, the project was awarded to the second-place winner, WSP Finland. The second phase of design (design development) was stopped due to financial problems at the end of 2004, at which time 60 percent of design development had been completed. After a four-year hiatus, in 2008 the client assigned its own Construction Management Department, a part of the Public Works Department, to publish a tender to find a general contractor to complete the construction works, and Skanska Civil was selected. As only 60 percent of the design documents were ready at the time, construction works commenced in the autumn of 2008 in parallel with completion of the detailed design documents. Completion of the project was expected in September 2010. See Figure 9–5–4 for an overall project timeline.

The contracting model used was design-bid-build (DBB), which was a little surprising given that only 60 percent of the design documentation was complete. However, the rationale was to allow selection of fabricators early, so that they could influence the final stages of design development. The steel fabricator, Ruukki Corporation, for example, was involved in completing the design due to their extensive knowledge and experience of steel detailing. The value of this strategy was proven as no problems related to the dimensions or quality of steel elements and structures occurred during construction.





**FIGURE 9-5-4**  
Project timeline.

### 9.5.1 The Crusell Bridge Project as a Learning Experience

The Crusell Bridge project became a BIM learning process for everybody involved, even for those who had previous experience using BIM, because many new solutions and techniques were tried. The designer had partially modeled the bridge in order to produce visualizations for the design competition. Because their concept design incorporated a large amount of steel work and had a need for accuracy, they recommended the use of modeling to the client to achieve better results. Thus the client decided to try modeling, not only modeling of the steel parts, but also all other constructions as well, including cast in-situ concrete structures with all reinforcement. Hence, the project became a pilot project for both the client and the designer. For the client, it was its first bridge project using comprehensive BIM, including time and management dimensions. While the designer had modeled simpler reinforced concrete bridges previously, this bridge, with its curved geometry, cable-stays, and composite structural steel and reinforced concrete structure, was significantly more complex than what they had experienced previously.

Bridge projects are quite different from industrial and housing projects because they have far more complex structures. While the use of computer modeling for structural analysis of bridges was essential and commonplace, at the time this project was undertaken the use of BIM for fabrication in bridge projects was not yet as common as its use in building projects. There are few BIM applications that can accurately model the complex structures and geometries that are common in modern bridges. Bridge modeling software is a specialized market with its own array of products, some of which have used 3D modeling. However, the integrated design facilitated by BIM software is new.

At the start of the construction stage, the contractor did not have access to the designer's model, although they knew of its existence. The designer had prepared Web models (simple models of the geometry of different parts of the bridge) that the bidders used in tender phase to understand the basic structures of the bridge and to prepare their competitive bids. However, once Skanska was employed, they received the full model that the designer had

prepared using Tekla Structures. Skanska made a strategic decision to use a model in the construction stage as much as possible, including 4D planning and modeling temporary structures. They had used modeling in housing and industrial construction projects, but using it on a bridge project was new for them as well. Using the model onsite also was a new experience as it was for all of the other parties to the project (subcontractors, surveyors, suppliers, and so forth) as well. The positive results on this project vindicated Skanska's decision, and they regard the experience gained as highly valuable.

Due to the pioneering nature of the use of BIM on a highly sophisticated bridge, the main BIM software provider to the project, Tekla Corporation, was also involved. Providing intensive support to the project team, Tekla too learned a great deal. Throughout the design and construction process they helped the team members learn and then apply new features of the Tekla Structures modeling software: sharing the model over the Web (synchronization); 4D planning; synchronization of the model with suppliers' factory management software; and export of fabrication data directly to computer-controlled machinery.

Consequently, the project became a unique learning process for all the parties involved. Their willingness to learn new ways of working enabled them to succeed and to accumulate superb experience.

### **9.5.2 Interoperability**

Table 9-5-2 lists the various engineering software applications that were used through four different project phases: design competition, general design development, final structural design, and construction. The facility maintenance phase is excluded because at the time of this writing, the client had not yet decided how to proceed.

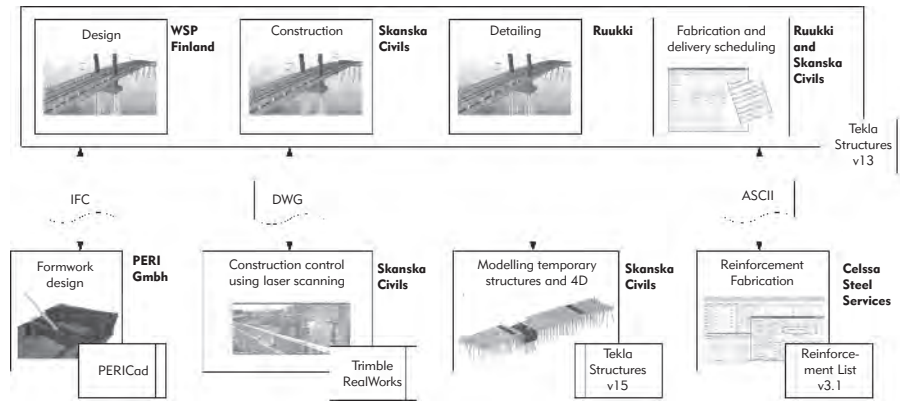
BIM tools were only introduced during the second part of design development starting in 2008. Up to the point when design development was interrupted in 2004, each software application functioned as a standalone tool. It is interesting to note that the application used for 3D modeling before 2004 was 3D Studio Max, which is a visualization tool, not a parametric object-oriented BIM tool. By the end of the four-year break, BIM tools had developed to the point where the design team considered them suitable for a bridge project of this complexity, and Tekla Structures was adopted. An additional factor that explains this progression is that Tekla Structures was, in its earlier versions, primarily a fabrication detailing tool, and less suitable for early design stages.

Until 2004 interoperability was not a significant problem, but when additional project partners were added in 2008, it became a major concern. An additional driver for resolving interoperability issues was that by 2008 there had

**Table 9–5–2** BIM and Other Applications Used for Different Project Phases

<b>Application</b>	<b>Developer</b>	<b>Purpose</b>
<b>Design Competition Phase</b>		
Integer SuperSTRESS	Graitec	Preliminary structural analysis—3D frame analysis
TASSU	T.Palosaari	Prestressed concrete beam analysis
KATA	WSP	Detailed structural analysis (2D bending of concrete sections)
AutoCAD	Autodesk	Drawings
3DS MAX	Autodesk	Modeling, visualization
<b>Design Development</b>		
Integer SuperSTRESS	Graitec	Preliminary structural analysis
Lusas Bridge Professional (FEM)	Lusas	Main structural analysis
TASSU	T.Palosaari	Prestressed concrete beam analysis, stresses and cracking
KATA	WSP	Detailed structure analysis
PILG	WSP	Pile force analysis
Tekla Structures v13	Tekla	Structural design of abutments and pylon, drawings
AutoCAD	Autodesk	Drawings
<b>Final Structural Design</b>		
Tekla Structures v13	Tekla	General concept of bridge, drawings of the structure
Lusas Bridge FEM	Lusas	Structural analysis
AutoCAD	Autodesk	Some drawings
MathCad	PTC	Mathematical analysis, e.g., prestressing and concrete creep
<b>Construction</b>		
Tekla Structures v13	Tekla	Basic use onsite—viewing of the model, quantity surveying
Tekla Structures v15	Tekla	4D simulations and temporary structures. Version 15 was adopted for this use as soon as it became available because it provided built-in links between schedule and model
PERICad	PERI	Modeling formworks
Reinforcement List v3.1	CELCA	Steel service (reinforcement)
Trimble RealWorks	Trimble	Comparing surveying results to design
Vico Control	Vico Software	Preparing master schedule

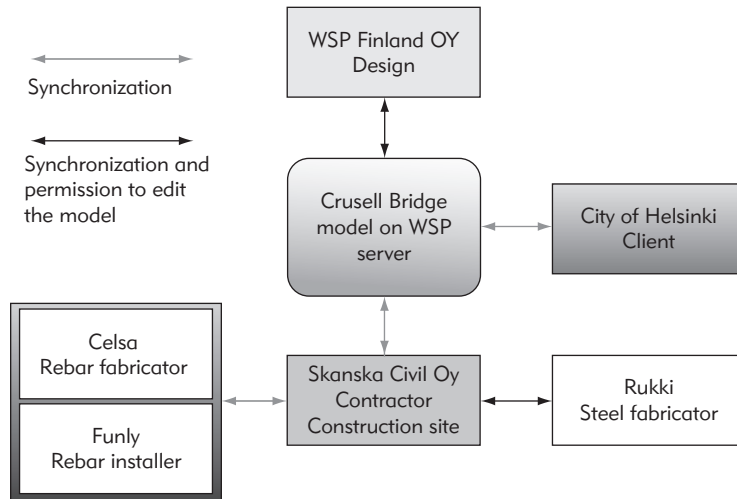
**FIGURE 9-5-5**  
Information exchange  
through file transfer.



been major advances in the capabilities of modeling software, so that it could be used by more partners for more tasks. The first and most obvious way in which this was tackled was by all major participants—client, designers, general contractor, and major subcontractors—agreeing to use the same primary BIM tool (Tekla Structures). Data exchange between these partners was thus reduced to a question of data synchronization, which is discussed later in this case study. Nevertheless, data also had to be exchanged with other applications, such as Trimble RealWorks, Vico Control, PERICad, Reinforcement List v3.1, and the fabricators' ERP systems. Where this required only geometry exchange, such as between Trimble RealWorks and the Tekla model, the DWG file format was used. When richer information exchange was needed, such as between the Tekla Model and PERICad, IFC files were used. When alphanumeric data sufficed, or where geometry could be described parametrically rather than explicitly, such as for defining rebar shapes for fabrication, simple ASCII file formats were generated from the Tekla model. These exchanges are shown in Figure 9-5-5.

### 9.5.3 Model Synchronization

Many different participants are involved in every construction project, and each develops domain-specific building information models. To improve information exchange and communication between them, Tekla, like other BIM vendors, has developed functionality to synchronize the models maintained by different participants. Tekla's products use a central vendor synchronization server. The Crusell Bridge project was the first bridge project to employ this capability. Synchronization was critical for the project, because, as can be seen in Figure 9-5-4, detailed design continued over a long period in parallel with the construction work. This is common for fast-track projects, less so for traditional design-bid-build. Synchronization between Skanska's contractor model and Ruukki's fabrication model also proved essential, and this relationship is



**FIGURE 9-5-6**  
Information exchange  
through synchronization.

common in all projects where fabricators undertake fabrication detailing. The client began using the synchronization server later (in autumn 2009).

Synchronization was performed on a weekly basis, but this was not a hard and fast rule. Whenever the designers made significant changes to the model, they informed the site. Site personnel could then synchronize and get the latest version of the objects “owned” by the designer updated into the construction model. Because the contractor also modeled temporary structures, formwork, and other features, only the designer’s objects that had been changed were added at each iteration, replacing the previous ones. The contractor’s project information officer could filter and identify those that had been updated, and see where and how the changes impacted the construction model. In this way, it often happened that the general contractor had information about the changes in the model well before the drawings were approved by the client, so that they could prepare in advance for the near future (faster exchange of information). Synchronization between the site and subcontractors’ models was also done, but on a less regular basis, mainly in response to changes made. The flow of information using synchronization is detailed in Figure 9-5-6.

Synchronization required not only a technological solution, but also a management protocol, agreed to by all parties, that stated who was allowed to edit what and when. The protocol outlined the following procedure:

1. WSP (designer) uploads design changes to the model synchronization server;
2. Skanska uploads scheduled changes to the model synchronization server;

Enni Laine, Skanska's project information officer at the Crusell Bridge site: "This synchronization practice has been really good. Information exchange has been really transparent and everything has worked very well. Probably a big part of this interoperability and success in synchronization has been dependent on the people. Openness between the teams has probably helped us to learn more about BIM and find out the good practices. Collaboration between different project participants is a crucial factor in successful BIM utilization."

3. Ruukki uploads fabrication changes and schedule updates (dates of order, fabrication, delivery, and so forth) to the synchronization server;
4. All participants download "change" files and import them to synchronize their own models.

An interesting problem arose with the synchronization during the project. When Skanska upgraded their version of Tekla Structures to version 15, it was found that synchronization of rebar data led to anomalies between their model and that of WSP, whose model was compiled and maintained with version 13 of the same package. Once Skanska upgraded, this limited synchronization to a single direction.

#### 9.5.4 BIM Use in the Construction Phase

In this section we describe and discuss the numerous ways in which BIM was used for managing and organizing the construction phase, both directly as an information source and as a supporting technology for lean construction practices.

The Crusell Bridge is not an extremely large project, but has an interesting design and makes excellent use of BIM for a number of construction purposes. It is fair to say that the model drove the construction in every aspect. All of the bridge's structure was modeled, down to the last reinforcing bar and all of the temporary supporting structures and concrete formwork. Skanska maintained the model on a server at the construction site office, and appointed a civil engineer to the role of "contractor information officer," whose responsibility was to provide information to all project participants and to maintain and update the contractor's model.

Why did Skanska maintain the model onsite? At the time work began, the design was incomplete, and so the project could not be thoroughly scheduled. Site teams were suspicious at first, not understanding how the model would benefit them, or what they could use it for. But everything was modeled, and the contractor's model was continuously synchronized with the designer's model as

it developed. The contractor's model became the primary source for all information for teams on site: for dimensions, for visualizing how to build different parts, for procedures, for material delivery reports, and so forth. The information officer was kept busy providing all the information requested from the model.

Although the initial model of the final bridge product was prepared by the designers, Skanska added to it and edited it to reflect the construction process as well. The model was used a great deal for task and work sequencing, and for viewing work. All of the temporary structures—shoring towers, temporary piles, formwork and equipment—were modeled. Carpenters would come to view the model to understand complex geometry before and while preparing the concrete formwork, such as the doubly curved stems of the pylons. Interestingly, due to limitations of the Tekla Structures software version in use at the time, complex double-curved geometry could not be generated in the native application. To overcome this difficulty, the geometry of these faces was generated in 3Ds Max and imported into Tekla as reference geometry using DWG files. This issue has been addressed in newer versions of the Tekla Structures software as a direct result of the company's engagement with the project team. Tekla viewed the Crusell Bridge project as a pilot study for application of the construction management functionality in its software.

The following details the different ways in which models were used for construction management, with emphasis on use onsite for day-to-day operations.

### **Visualization**

Use of building models as a visualization tool is one of its most obvious uses with the clearest advantages. The 3D model of the project helps different parties to better understand the concept and especially the details of the design, forming a common mental picture and understanding far more quickly and effectively than with traditional drawings. The model was made available to all work crews on the jobsite, and they made extensive use of it, coming to the office to view it from time to time to explore the finer details of positioning of formwork, cable anchors, and reinforcement. For example, as can be seen in Figure 9-5-7, the cable anchors are heavy and they have to be supported before casting. Large quantities of reinforcement were positioned next to each cable anchor. Planning how to support the cable anchors within the forms in preparation for concrete pouring was much easier with the 3D view, which could be manipulated and cross-sectioned in multiple directions.

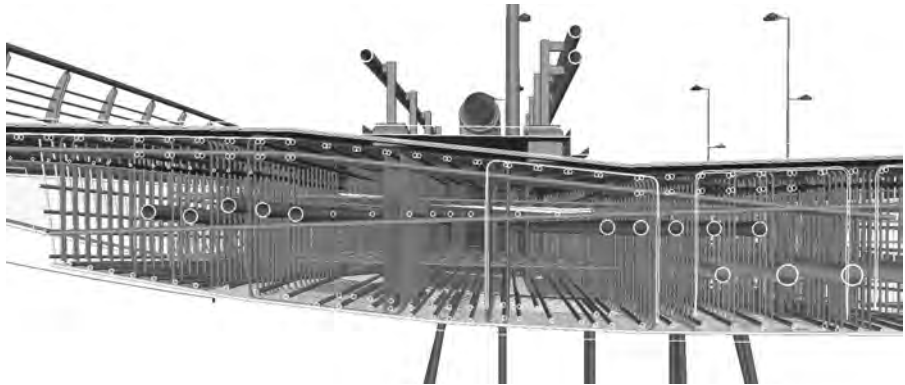
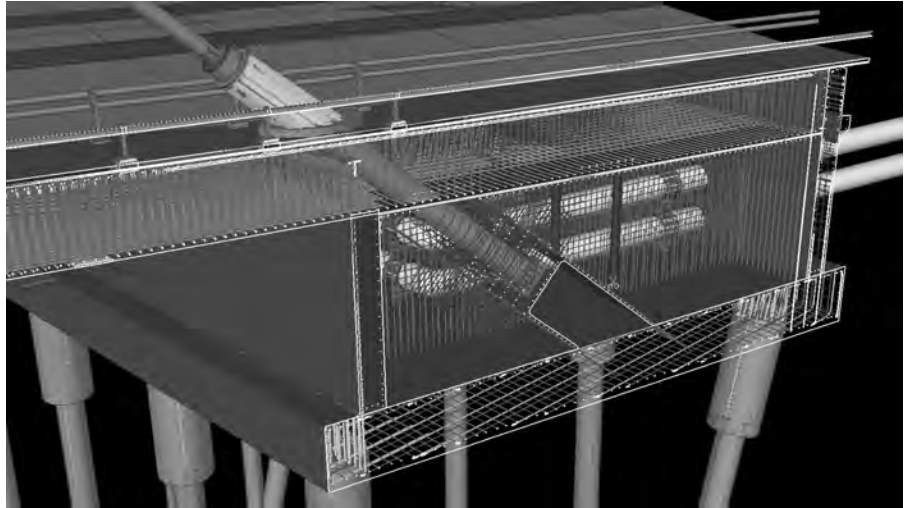
### **Design and Planning of Temporary Structures and Clash Detection**

Initially, the site crew was provided with many drawings of the formwork, but this did not include the extensive formwork support towers and other temporary

**FIGURE 9-5-7**

Cut section views showing reinforcement details in relation to other cast-in hardware, such as the large cable anchor assemblies. (See color insert for full color figure.)

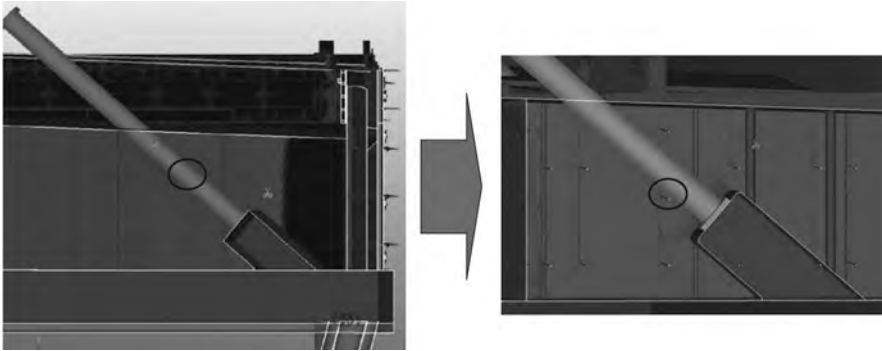
Image courtesy of Skanska Finland.



structures, such as scaffolding for access. As a result, the site team decided to thoroughly model all the missing temporary structures, including formwork shoring towers and the site tower crane on its tracks, directly in the design building model maintained onsite. This provided a better understanding of the structures, enabled identification of numerous collisions (clashes), extraction of accurate quantities, incorporation of these works into construction schedules, and visualization of their sequencing during 4D planning.

Clash detection was done not only at the end of the design phase between steel and concrete parts, but also in the construction phase, incorporating additional systems and the temporary structures and formwork. Many clashes in the bridge structure that might only have arisen during construction were thus prevented. This BIM functionality saved a large amount of money and prevented many problems. For example, the formwork supplier, PERI, designed



**FIGURE 9-5-8**

Example of a clash detected between a cable anchor and formwork ties and its resolution.

Image courtesy of Skanska Finland.

the complex forms for the piers using their in-house CAD system (PERI CAD: [www.peri.de/ww/en/products/service/software\\_e/peri\\_cad\\_e.cfm](http://www.peri.de/ww/en/products/service/software_e/peri_cad_e.cfm)). The bridge geometry was first transferred to PERI CAD from Tekla using IFC file exchange, the formwork and support towers were then designed, and finally the formwork models were returned to the construction model, again using IFCs. To the team's surprise, clashes were identified between the bridge cable anchors and the ties between formwork panels on opposite sides of the anchor. The formwork design was changed to resolve the issue (see Figure 9-5-8).

### ***Construction Planning and 4D***

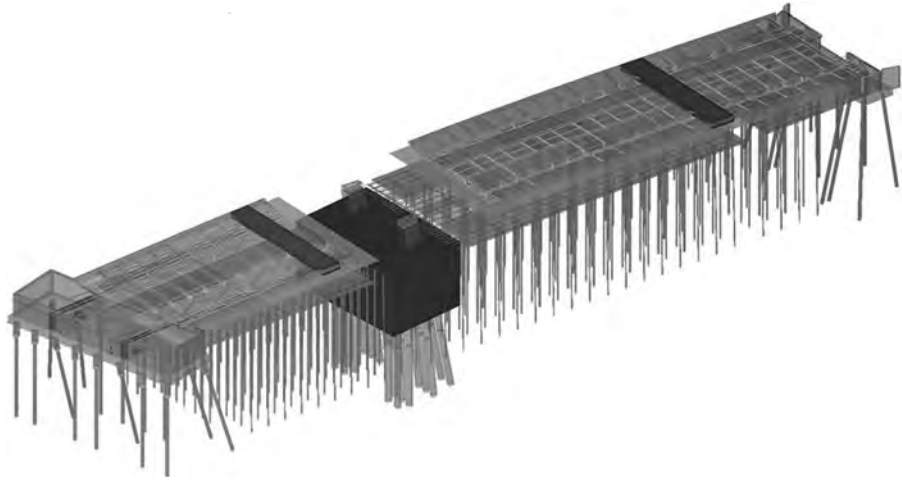
The building model was first used during overall master planning meetings and then also in reverse-phase scheduling meetings, which are a part of the Last Planner System™. Vico Control™ software, which implements location-based construction scheduling, was used for the master scheduling, with the model used only for visualization. The master schedule was then imported into the “task manager” view of the construction model in Tekla Structures v.15, where the schedule was detailed. Deck construction was divided into at least two, and whenever possible three, independent workspaces where work could be performed in parallel, executed by different parties. The model was used to perform this fine-grained level of workspace planning, in terms of spaces, work sequences, quantities, and other spatial information. Objects in the model were assigned to construction activities and were color-coded. Figure 9-5-9 shows a section of the deck on a particular date, with two work sections shown marked in red and blue (see color insert).

The 4D video animations of the schedule were done at the resolution of a single day. Thus the team could generate daily visualizations of the project, which enabled assessment whether the decisions made during the reverse-phase scheduling stage of the Last Planner System™ (LPS) meetings were

**FIGURE 9-5-9**

Separate work sections, shown color-coded in red and blue in the original (appear as different darker shades of gray in this image). (See color insert for full color figure.)

Image courtesy of Skanska Finland.



realistic in terms of their use of space. The animations also gave everybody a better understanding of which works they were agreeing to execute when.

The model enabled the team to develop more detailed and accurate work plans than they could have achieved otherwise, as it provided accurate spatial information and gave more precise quantities of the materials needed. It proved easy and quick to extract precise material quantity takeoffs from the Tekla Structures model, which helped reduce the need for excess buffers of materials and guaranteed that only the necessary materials were ordered from suppliers.

However, since association of objects to activities was done manually within the Tekla Structures model, the initial setup was fairly time consuming. After severe engineering problems with the piles of the central pier were identified, the construction work fell some two months behind schedule while new concrete piles were poured to the sea bed to replace defective piles. As a result, the project team decided to reverse the overall sequence of bridge deck construction to allow time for the central pier columns to be rebuilt; instead of starting from one end and progressing to the other, passing the central pier in the process, work was commenced from either end and progressed toward the central pier. However, the 4D CAD model was not updated because the time required for redefining the logical relationships between the detailed tasks, and the relationships between newly defined tasks with physical objects in the model was considered to be more costly than the benefit that would have been gained from the process visualization. The uncertainty in the schedule itself was cited as an additional reason for not investing time to update the 4D aspects.

The lesson learned from this is that the construction scheduling aspect of the 4D software must be sufficiently sophisticated to allow definition of logical high-level task-to-task type relationships so that construction process changes can be made with the minimum of effort, by changing the rules governing the schedule, rather than by disconnecting and then reconnecting the logical relationships between the detailed tasks. In this way detailed tasks would not have to be redefined and re-associated with physical model objects. At the time, Tekla Structures did not support this level of sophistication in task scheduling.

### ***Fabrication and Installation of Structural Steel Components***

The bridge model was shared with the steel fabricator, Ruukki, who supplied the project with steel parts and assemblies. Ruukki reviewed and edited the components in the model as needed to suit their fabrication constraints, and then sent the updated model back to the structural designers at WSP and to Skanska for approval. WSP then edited the structural steel components in its own model, incorporating Ruukki's comments, and updated the server model for all other participants.

In addition to exchanging design information using the model, they also used it to exchange production sequence information in both directions. Since Ruukki had the same model that Skanska had, and synchronizations were performed regularly, Ruukki used the construction schedule data from the model to determine their fabrication and delivery schedule. They then updated the model with their own fabrication, inspection, and delivery dates. The internal data transfer, between Ruukki's model and their enterprise resource planning software, was done manually, but they believe that this transfer can be easily automated in the future. Since the construction schedule was updated after each planning meeting and the information was available in the model, procurement of the materials was more accurate, logistics could be organized better, and ultimately delivery and erection of components onsite could be "pulled" using the detailed model information.

Erection of the structural steel onsite was performed by Siltera, who was employed by Ruukki under a subcontract. They did not use the model regularly, but did consult it from time to time to obtain detailed product and process information concerning their work, particularly where drawings were not clear and questions arose.

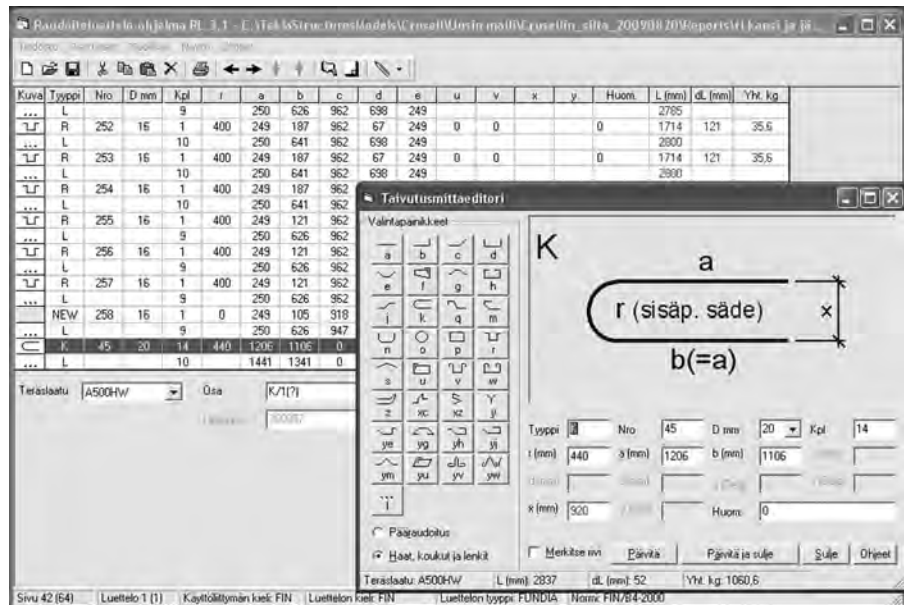
### ***Rebar Detailing, Fabrication, and Installation***

Modeling the bridge reinforcement turned out to be more difficult than was anticipated. Bridges of this type (cable stayed) have a high density of reinforcement and complex deck and abutment shapes, which makes the modeling more

**FIGURE 9-5-10**

Screenshots from the fabricator's in-house software for reinforcement fabrication, showing rebar data imported directly from Tekla reports extracted from the bridge model.

Image courtesy of Skanska Finland.



difficult and time consuming than for simpler structures. In most common reinforced concrete structures, building elements such as beams, columns, and foundations are sufficiently standard in shape and reinforcement details to allow the use of parametric objects and rebar layouts that greatly accelerate modeling; bridge elements have unique geometries due to curvatures, which often require that they, and their reinforcement layouts, be “custom” modeled.

Nevertheless, although the modeling effort was carried by WSP, all project participants benefited from it. WSP was required to produce rebar detail drawings in any event, as this was still a contractual obligation imposed by the client (for archival purposes and for the use of rebar installers in the field), and the drawings were produced directly from the model. Many spatial conflicts between reinforcement and other structures were prevented at an early stage by using clash detection, and model information was used to drive the rebar bending and cutting machinery.

Tekla Structures provides rebar material takeoffs in ASCII, EXCEL, and other file formats. For the Crusell Bridge project, ASCII report files were formatted in such a way that they could be imported directly and automatically into the suppliers' rebar fabricating software with all of the information for bending and cutting (see Figure 9-5-10). This software drives the NC machinery on the shop floor. The formatting was done in cooperation with the CELSA Steel Services (the rebar fabricator), Skanska, and with technical support from

Tekla. Naturally, this removed a great amount of human effort and the potential for error.

However, Skanska was unable to achieve the same degree of integration with CELSA as they had achieved with the structural steel supplier, who had the ability to use BIM software itself. The ASCII file exchanges used here were specifically tailored to communicate rebar shapes and quantities, and these were unable to carry the full range of information that model synchronization would have provided. Some of the information was still exchanged manually. As a result, tasks like bundling of rebar into lots for delivery and installation were scheduled externally to the model.

The rebar workflow was as follows:

- WSP uploads design changes to Skanska's model (WSP detailed all of the rebar, which became the bottleneck activity in the process, so that the flow of rebar detail information was continued over a long time).
- Skanska selects objects and rebars in the model according to the construction schedule (which was compiled and is maintained in the model).
- Skanska exports the modified rebar reports (based on ASCII reports) to CELSA.
- CELSA imports the data into their "Reinforcement List 3.1" package, and the rebar is then fabricated and delivered.
- Skanska's project information officer prints model "snapshots" of the rebar cages from Tekla. The foreman shows these to the workers, who use them with the drawings for assembly.

Rebar was installed onsite by Funnly, a company specializing in tying rebar. Funnly's employees used only paper drawings for their work onsite. The extremely wet and cold conditions that prevailed onsite for most of the construction duration precluded direct use of a laptop or other electronic equipment to provide model views at the work face, and Funnly did not have any staff available that could operate modeling software. However, for a number of reasons, the 2D drawings produced by WSP from the model were often inadequate for the rebar installers. As explained above, the bridge reinforcing was dense and complex, and the drawings produced by the standard routines of Tekla Structures v13 were either overwhelmingly detailed or lacking in information. This created friction between the project participants. A number of specific technical lessons were learned and conclusions were conveyed to Tekla for improvement of the automated rebar drawing generation routines in future versions.

Partly as a result of their difficulties with the drawings, the rebar installers were sometimes forced to consult the model, which showed every rebar and

**FIGURE 9-5-11**

Photograph and scanned point cloud shown together, showing the formwork and piles of abutment T3.

Image courtesy of Skanska Finland.



bolt, to get the complete picture of what was expected and how rebar cages could be tied. The contractor's information officer provided initial BIM training for Funnly, but they remained dependent on her to navigate the model for them and print screenshots when needed.

### ***Laser Scanning***

Skanska, the general contractor, employed a surveyor onsite whose task was mainly to control the quality of the work and to assist the trade contractors with positioning their works. Skanska began with equipment borrowed from the distributor, but once they gained experience and confidence with its use in conjunction with BIM, they purchased a Trimble® VX™ Spatial Station for use onsite. This machine can capture coordinates, take images, and combine them (see Figure 9-5-11); it is a two-in-one solution: tachymeter and camera. This made the surveyor's work much easier, because he alone could accomplish surveys that previously, with a traditional tachymeter, had required two people.

The point clouds and the pictures acquired were uploaded to Trimble RealWorks software, where they were compared with the design location coordinates transferred from the modeling application, Tekla Structures. This enabled real-time quality control for locations of structural components, formwork, and hardware embedded in concrete. For example, when placing a large bridge cable anchor, a 1-centimeter difference was identified between the model and real-world locations, and so the anchor position was adjusted and checked again before concreting.

The information officer taught the surveyor to use the bridge model for his purposes. The surveyor said:

“Although extracting coordinates from the model was quite complicated, the model was very useful. I got accurate dimensions from it and it helped me to understand what and how must be done if something was unclear during the construction work.”

The surveyor attended all planning meetings, including the Last Planner weekly work meetings, where he helped determine whether all the technical information needed for completing a candidate task was available or if there were any constraints that remained to be resolved before work could start.

### ***BIM Support for the Last Planner System™***

Skanska Civil, Finland, had used the Last Planner System™ (LPS) in their projects for three years prior to the Crusell Bridge project, and have their own specialists who train site crews to use it. The LPS can be understood as a mechanism for transforming what *should* be done into what *can* be done by working to release constraints on tasks, thus forming an inventory of ready work, from which Weekly Work Plans can be formed. It has two main focuses: reliable short-term planning, and creation and development of a social system onsite (team building, network of commitments, promises, and mutual trust and respect).

In the Crusell Bridge project they followed traditional planning phases of the LPS, but with some exceptions. The main suppliers and specialty trade contractors all participated in reverse-phase scheduling meetings to plan work three to five months ahead. These meetings generated the network of tasks that must be executed, and thus a network of commitments. During the reverse-phase scheduling meeting, they used the model to visualize what tasks comprised and how they had to be done. Subsequently, the site manager transferred the results of reverse-phase scheduling into the Artemis PlaNet software (a local planning tool akin to MS Project) to clarify and reconfirm that everybody understood what they were expected to do.

The next level of planning was look-ahead scheduling. Here they planned three weeks' work by screening each task's constraints and resolving them wherever possible. The look-ahead schedule was prepared by Skanska's site crew in cooperation with the subcontractors, after which the tasks were transferred into weekly work plans. The “five why” technique was used to identify root causes for any tasks that could not be completed despite use of the LPS. This analysis made it easier to remove root causes for delay from the production system. The

team only measured the Percent Plan Complete (PPC) over a limited period. The mean value was 84 percent, but the range was wide, with a standard deviation of 11 percent. The designers did not participate in the LPS meetings held by the contractor at the site, and indeed rebar detailing became a bottleneck in the process. The project manager thought that 4D planning could have been used more intensively to complement the different planning phases in matters of space use, for instance, to identify collisions or interferences between work units. The project manager suggested that in retrospect, designer participation in the scheduling meetings could have been extremely useful, because the sequence of preparation of the detailed drawings, which became a bottleneck activity, could have been pulled by the LPS if they had participated.

Site personnel admitted that they still had a lot to learn about the LPS. Using this approach gave them better understanding of time, flexibility, and the problems that hindered work. It became clear that production problems onsite tended to arise whenever subcontractors missed planning meetings. An additional complication was that subcontractors gave unreliable dates for task completion, promising to deliver work that couldn't actually be completed by the date promised; this is precisely the type of behavior that the LPS is designed to prevent.

### **9.5.5 Summary, Conclusions, and Lessons Learned**

Modeling, as a virtual representation of reality, provided multiple benefits for the parties involved in the Crusell Bridge project. According to all project participants, the intensive use of BIM for construction management enabled better management and organization, and saved time and money.

The case clearly illustrates how BIM can be used in a bridge project. The teams' willingness and openness to using BIM and new management methods (LPS) gave all of the parties the opportunity to experience and learn from their own failures as well as from their successes. Much knowledge and experience was gained, which has already found expression in enhancements and improvements made to the delivery processes for future projects and incremental improvements to some of the software used. While these methods will become common in complex projects of this kind, there will always be problems, and the Crusell Bridge was no exception. Given that such use was new for all of the team, it is understandable that obstacles were encountered and problems occurred. The ways the problems were tackled, and the steps taken to remove or mitigate them, were drivers of positive change. Antti Karjalainen from WSP Finland said that, "the project results, both positive and negative, have been used as the basis for bridge BIM development and other software enhancements."

Finally, we summarize some key lessons learned during the project:



- Plan using BIM and LPS from the very beginning of the project: set objectives, conduct initial training, and create an environment and willingness for learning and improvement.
- Use the model to complement construction management techniques (planning, control, information exchange, meetings, quality control, and so forth).
- Use the model synchronization feature to achieve fast information exchanges.
- Use 4D scheduling to help understand and assess whether the network of commitments created during reverse-phase scheduling is realistic.
- Model temporary structures if they form a significant part of the construction works (this provides accurate quantities), and if 4D planning is being done; it gives a better understanding of the period over which temporary structures are needed.
- Importing laser scanning point clouds into the model to check locations and work quality is highly effective. Used well, it can prevent a great deal of rework.
- Use the model for visualization during LPS planning meetings to improve understanding of the product and the process.
- Involve project partners from outside the site as well as site teams in periodic LPS planning meetings, to synchronize pull of detailed design/fabrication information as well as fabricated components.
- Ensure that all participants are committed to upgrading their software tools simultaneously, so that problems related to backward compatibility between different versions of the same application are avoided.

## Acknowledgments

---

This case study was researched and compiled by Rafael Sacks and Ergo Pikas, a civil engineer who graduated recently from the Tallinn University of Applied Sciences and is a founding member of the Estonian Group for Lean Construction. The authors are indebted to a number of people who played key roles in the Crusell Bridge project and took the time to be interviewed and to provide extensive information: Ville Alajoki (City of Helsinki Public Works Department), Antti Karjalainen (WSP Finland), Teemu Nivell (Tekla), Jan Elfving (Skanska), and most of all, the project information officer Enni Laine (Skanska Civil).

## 9.6 100 11TH AVENUE, NEW YORK CITY

### *BIM to Facilitate Design, Analysis, and Prefabrication of a Complex Curtain Wall System*

#### 9.6.0 Introduction

This case study identifies innovative approaches in the implementation of building information modeling, with a special focus on the ways in which BIM facilitates design, communication, and analysis for curtain wall design. The building, located in Manhattan near the Westside Highway and 19th Street, is a 21-story residential condominium with overall dimensions of 150 ft L  $\times$  75 ft W  $\times$  235 ft H. Figure 9–6–1 shows a rendering of the building and a hidden-line view of the curtain wall. Table 9–6–1 lists the members of the project team.

The site is located in an area of Chelsea that does not have the same physical qualities and amenities as other surrounding areas, such as Greenwich Village, where the Perry Street condominium project by Richard Meier has a nearby park, high-end retail, and a subway stop. The Highline project, however, is catalyzing a significant transformation of this area, with a series of projects planned by various renowned architects.

This building provides a river view of the downtown financial district and the New Jersey shore. The curtain wall façade is therefore an iconic element of the design. A key concept of the curtain wall is that it is not a load-bearing enclosure but hangs from the structure of the building. There are also technical and environmental issues relevant to a glass curtain wall, such as water

**FIGURE 9–6–1**

100 11th Ave. in Manhattan, a condominium project by architect Ateliers Jean Nouvel.

Image provided courtesy Ateliers Jean Nouvel.



**Table 9-6-1** The Project Team

Ownership Group:	Cape Advisors + Alf Naman Real Estate
Design Architect:	Ateliers Jean Nouvel
Architect of Record:	Beyer Blinder Belle
Construction Manager & General Contractor:	Gotham Construction
Facade Consultant:	Front Inc.
Structural Engineer:	DeSimone Consulting Engineers
Acoustic Consultant:	Cerami & Associates
Curtain Wall Fabrication Team:	CCAFT, SGT, KGE

impermeability and insulation, which constrain the morphology of its surface. In this case, housing ordinances affecting new buildings along the Westside Highway prescribe a sound transmission class (STC) of 42 for the façade. In this project, the view is the driving element for the curving of the façade and the configuration of its surface. Another key issue is the faceted surface, which consists of a series of planes tilted along multiple angles and axes.

Front Inc. was brought in early in the process, at the concept design stage, to assist the ownership group in evaluating the feasibility of two preliminary proposals prepared by the design architect. The proposal selected for the overall exterior surface has two systems. Glass covers 40 percent of the surface area, which complies with the New York State energy code provision, which imposes a 50 percent maximum. The remaining 60 percent of the surface area is clad in custom black brick with random window openings, within which each window is set at a tilted angle. The curtain wall system changes at street level to a hybrid system of a faceted curtain wall and a series of cavities with large planters that affect the loading system.

The average cost for the overall exterior surface is calculated by weighing the cost of each system typology by its proportion of the total surface area. The glass and steel façade system, covering 40 percent of the building, was procured at approximately 2.5 times the cost of standard uniform curtain wall systems, while the brick and window façade was purchased at approximately 1.0 times the same benchmark. Thus the average cost was:

$$2.5 \times 40\% + 1.0 \times 60\% = 1.6 \times \text{the standard uniform curtain wall cost}$$

Relative to the cost typically incurred by condominium developers for façades, this system is expensive. The construction cost is estimated at approximately 25 percent of the overall hard construction cost of the entire

building. A typical range is 12 to 15 percent. Although 25 percent is high, it is still less than cladding systems designed by architects such as Gehry Partners, Asymptote, or Sejima, Nishizawa & Associates, which have costs in the range of 25 to 40 percent of the total construction cost for some building projects. It is clear that for specific projects, special façade systems have generated cultural, environmental, marketing, and other values.

### 9.6.1 BIM Process: Innovation and Challenges

Building information modeling systems are being adopted as a powerful tool in the AEC community. Their many features include a robust parametric modeler, analysis tools, spreadsheet functionality, API, and file export functionality. In the case of Front Inc.'s use of Digital Project (DP) for this building, the major innovation was in the implementation of modeling tools early in the design process. They were able to update and store all product information for the curtain wall design and exchange this data with the rest of the project team.

#### *Parametric Modeling*

Marc Simmons and his team at Front Inc. worked as consultants for the ownership group for approximately six months during the concept phase of the project. The design architect, Ateliers Jean Nouvel, and Front Inc. collaborated in the conceptualization of the façade system. The challenge in this phase was to identify rational ways to systematize the design without compromising the aesthetic value of the design concept.

**Material Selection.** The choice was made to use steel over aluminum for the framing system, because aluminum would require connections to be detailed as moment connections with large fasteners and exposed bolts. In addition, with the complex pattern proposed by Jean Nouvel, linear continuity for the load path would be difficult; however, a welded steel frame could be variegated to provide this type of *Mondrianesque* irregular pattern and still carry the loads as one network of welded steel members.

**Parametric Panels.** As can be seen in Figure 9–6–2, Ateliers Jean Nouvel provided a breakdown of the façade system as a composition of glass panels with four directions of rotation: tilting up, down, left, and right; four glass variations; and angles of rotation varying through 0, 2, 3, 4, and 5 degrees off vertical. Front Inc.'s first step was to create an Excel spreadsheet (Figure 9–6–3) for organizing these parameters along with the glass panel dimensions. The Excel file would be referenced as a design table in Digital Project to associate all parametric variations.

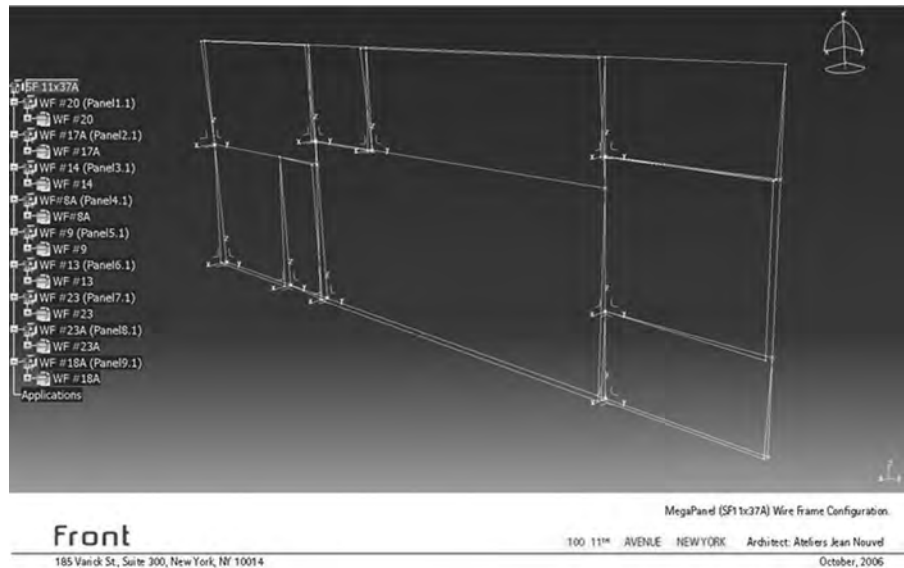
**Mega-Panel Assembly.** Front Inc. proposed a basic grid system that could be concealed within the pattern of the façade by keeping the width of the steel



**FIGURE 9-6-4**

Original parametric Powercopy of a mega-panel in Digital Project.

Image provided courtesy Ateliers Jean Nouvel and Front Inc.



members constrained to 3 inches, as agreed upon with Ateliers Jean Nouvel as a reasonable dimension allowing for both structural efficiency and integration of panel mechanics. This allowed for the subdivision of the system into mega-panels for framing glass subpanels of varying dimensions, tilt, and materiality. In Digital Project, the mega-panels were part-body assemblies with a basic parametric wire frame, as shown in Figure 9-6-4.

The mega-panels were associated with a design table and created as a *Powercopy* that could be initiated using values from the spreadsheet. A *Powercopy* is a type of feature template in Digital Project, where the elements are accessible for editing. In the case of each mega-panel, the overall dimensions conform to each room within the building and become a picture frame. The mega-panel dimensions vary from 11 ft × 18 ft to 20 ft × 37 ft, and they affect the dimensions and number of component subpanels.

**Curtain Wall Assembly.** The overall façade system is made of steel with a regulated grid composition of mega-panels and a randomized subdivision of glass panes held in aluminum cassettes. In Digital Project, a design table organizes the variations of the 1,351 individual glass panes that make up the façade, by dimension, configuration, and location in the grid. The frames of the mega-panels have members 1~HF in. wide by 6 inches deep on two sides and the top. The bottom member is 3 inches wide by 6 inches deep. The profiles of the mullions that subdivide the mega-panels vary in cross-section (3 × 3 in., 3 × 4 in., 3 × 5 in., and 3 × 6 in.) to account for variations in loading. Steel profile

protrusions at the intersections of the mullions vary in length to provide the specified angular tilt of each subpanel. The triangular gaps between the glass panes and resulting mullions are closed with steel plates at the head and sill of each pane. The extensions are welded and sanded smooth to maintain visual continuity between the mullion and the cassettes and to provide a place for thermal and acoustical seals. These details are shown in Figures 9–6–6 and 9–6–7.

The mega-panels are supported by floor slabs and connect through a steel spreader beam. The 4 in.  $\times$  10 in. beam is engineered to minimize deflection to 1/8 inch. The beam has two dead-load connections to the concrete slab and one wind-load connection. The mega-panel has multiple connections to the spreader beam, which uniformly distributes the loads. Therefore, the beam handles the deflection between the two systems. In fabrication, each mega-panel would be preassembled and the beam connected to the panel onsite.

### ***Fabrication Activities***

**Fabrication Team.** For the bidding phase, Front Inc. did preliminary engineering of the steel and produced a set of drawings for pricing. All bidders came back with bids much higher than the cap price stipulated by the ownership group. Front Inc. believed that their skills and BIM technology would enable them to deliver the façade at a reasonable cost and asked permission from the owners to form a team that could deliver the project. There was an opportunity for great profit, but the financial risk was also very high. Marc Simmons, the principal of Front Inc. was prepared to work as design consultant on the façade contractor side, executing all aspects of the design and incorporating them into the master Digital Project model. Private investors joined forces with China Construction America (CCA), a subsidiary of China State Construction (the largest construction company in China), to establish a new façade contractor named CCAFT. This new company had the financial strength to provide bonding for the project, including the ability to subcontract fabrication to China-based fabricators, such as SGT and KGE; to subcontract design work to Front Inc.; and to subcontract installation work to Island Industries in New York.

**Visual Mock-up.** A 15 ft  $\times$  42 ft visual mock-up was fabricated by SGT and reviewed in Shenzhen with the ownership and architects in January 2007. The mock-up consisted of two curved corner mega-panels and two flat mega-panels, as shown in Figure 9–6–5. For the visual mock-up, the steel, aluminum, and glass were generated as a 3D solid model in Digital Project, with the design table information driving the associative parametric subassemblies in the wire-frame armature. From this 3D model, SGT was able to: extract fabrication geometry and prepare piece drawings according to their own format and language requirements using Digital Project; and view and interrogate the

**FIGURE 9-6-5**

Photo of a 15 ft × 42 ft visual mock-up, fabricated by SGT in Shenzhen, China.

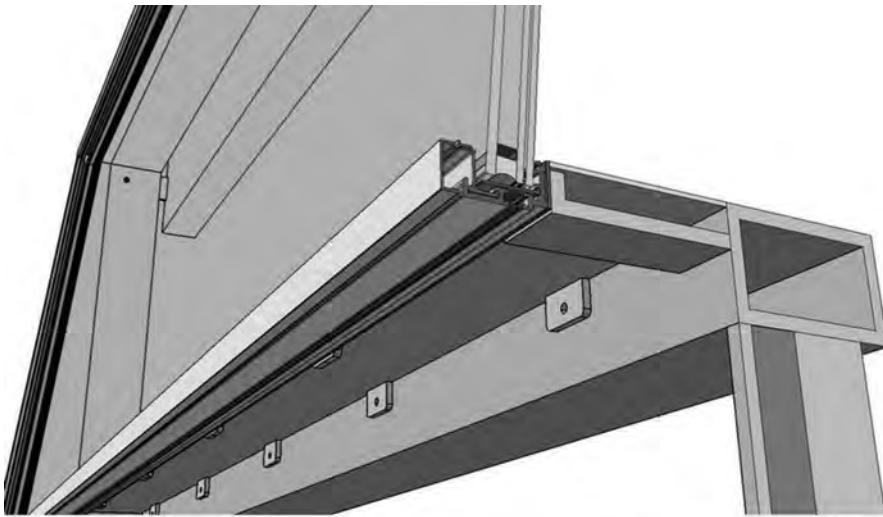
Image provided courtesy Ateliers Jean Nouvel and Front Inc.



model, which was exact and fully engineered in all regards. At the time the visual mock-up was fabricated, the extruded aluminum profiles were not yet available; however, SGT was able to use the same parametrically generated geometry to create CNC cutting patterns for a break-formed aluminum sheet, to replicate the geometry of the actual aluminum caps. In the performance mock-up, this geometry would be used to describe the milling and cutting paths for delivering the same effect with extruded aluminum profiles. Having the digital model available with such specificity at this stage was critical and enabled the creation of an exacting visual mock-up, despite it being out of the normal fabrication sequence.

**Performance Mock-up.** A 32 ft × 55 ft performance mock-up was to be fabricated and delivered in July 2007 for testing at ATI in Pennsylvania. This mock-up consisted of two curved corner mega-panels and two flat mega-panels, as shown in Figure 9-6-6. The mock-up mega-panels were fully detailed to include locations for the cranes to hook and transport the preassembled panels, to keep them level as they are hoisted, and to minimize any risk of glass breakage. The mock-up was also intended to provide valuable information on the process of exchanging product model data with SGT, their ability to meet design and engineering specifications, and to work within the shipping and delivery time constraints. It was also a critical learning and proving stage for





Front

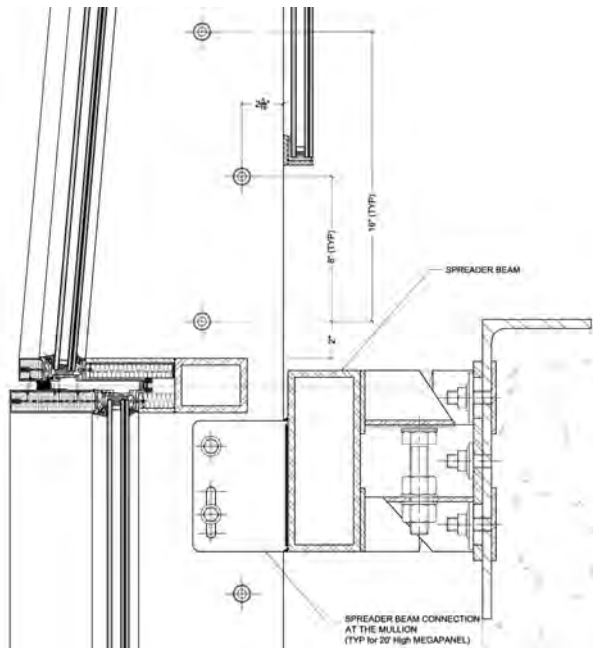
185 Varick St., Suite 300, New York, NY 10014

100 11th AVENUE NEW YORK Architect: Anders Jean Nouvel  
October, 2006

**FIGURE 9-6-6**

Cross-section view of mullions, extensions, and a glass panel.

Image provided courtesy Ateliers Jean Nouvel and Front Inc.



**FIGURE 9-6-7**

Slab edge detail.

Image provided courtesy Ateliers Jean Nouvel and Front Inc.

the installers, who would be responsible for taking ownership of the mega-panels and installing them correctly in the testing rig. Production and delivery of the mega-panels was planned to begin after review of the mock-up, in a sequence matching the construction schedule. The first installation onsite was scheduled for January 2008.

### 9.6.2 Information Exchange and Interoperability

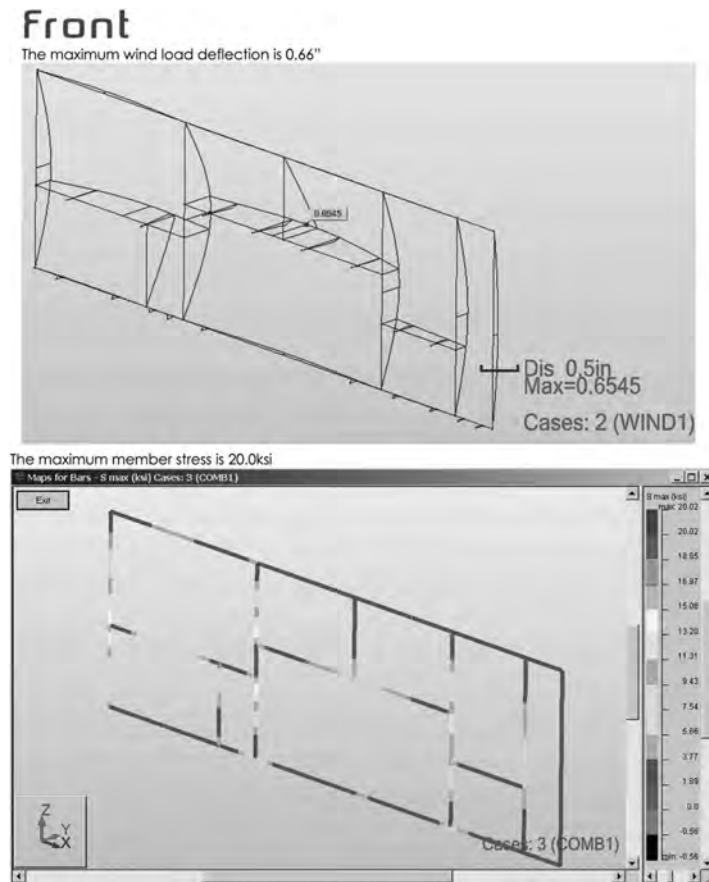
One of the most important aspects of BIM is the facilitation of information storage and exchange to enhance communication and collaboration in the design and construction process. Contractually, Front Inc. was responsible for engineering the design of the steel and overall system geometry. Although the glass gasket, aluminum, and silicone were not part of their contract, Front Inc. modeled all of this information. The model included high-level detail, such as the location of air-filled cavities and the meeting points of rain gaskets, to provide absolute continuity. The model also included different thicknesses of glass, edge bevels, and the thickness of the PVB (Polyvinylbutyral) interlayer laminated between the glass panes. Front Inc.'s model became the data repository for the entire curtain wall system.

Front Inc. used several different software programs, including Rhino, AutoCAD, SolidWorks, and CATIA. They found that CATIA and Digital Project (DP) have additional parametric capabilities, as compared to other BIM tools. In-house engineering design and analysis for this project was done using DP (for geometry and other information) and Robot and Strand (for structural analysis). For example, the mega-panel wire frame was exported from DP in an IGES format and brought into the structural analysis tool (Robot) to test deflection. Figure 9–6–8 shows how the mega-panels were analyzed for strength and deflection in Robot.

Profile cross-section details for the framing system were developed in AutoCAD, and the 2D information was imported into DP. This was done in 2D, because the architect of record required 2D drawing files as well as due to the limited number of skilled DP users. The façade was rendered in Flamingo and Viz.

At the start of the project, Front Inc. received a 3D model with a single-polygon representation of tilted glass panels produced in Rhino from Ateliers Jean Nouvel. Communication was done principally with renderings and other similar information to aid in the visualization of the design proposal and its implementation in the new model produced in Digital Project. The DP model was the façade contractor's (represented by Front Inc.) expression of the designer's intent, as defined in the Rhino model.

The façade had to be coordinated with the building itself, and that was done between the façade contractor and the architect of record, Beyer, Blinder, Belle (BBB), who produced the construction documents for the entire building. No construction documents were prepared for the steel and glass façade, allowing the DP model and contractor-side drawings to serve this function. For the façade, the approach was design-build, so Front Inc. and BBB shared shop-drawing information. A great deal of coordination with many iteration cycles was needed. Front Inc. produced documents and passed them to BBB as

**FIGURE 9-6-8**

Structural analysis of a mega-panel in Robot. (See color insert for full color figure.)

Image provided courtesy Ateliers Jean Nouvel and Front Inc.

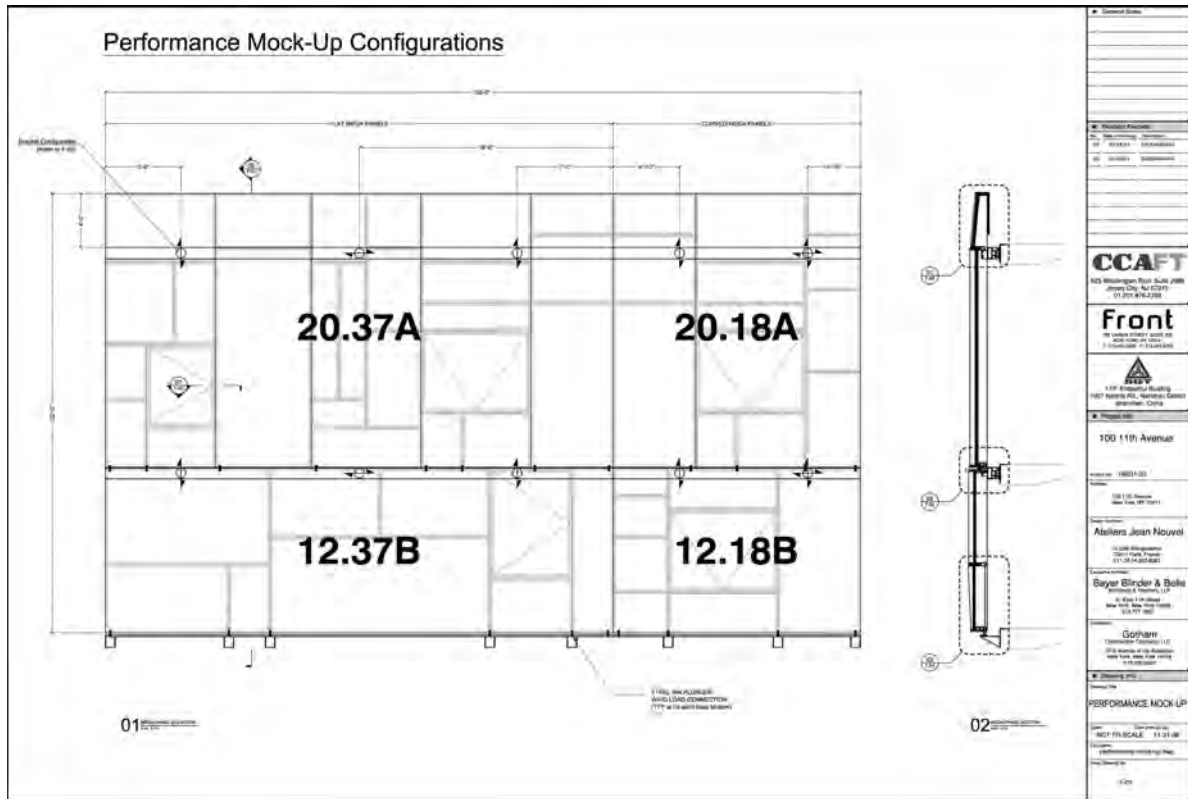
PDF files. They verified the coordination with their documents and sent information back to Front Inc. such as for slab edge profiles in AutoCAD.

Front Inc. provided the fabricator in China with the 3D model of the final geometry and all other product model information in a CATIA file format. From this model, the fabricator extracted all of the drawings necessary for fabrication.

### 9.6.3 Lessons Learned

#### *Parametric Curtain Wall Catalog*

The most valuable result of the full use of a building model was the ability to use parameters associated with a spreadsheet and predicate rules in the production of feature templates that could be reused. The parametric assembly was used to generate multiple solutions for various conditions. By using this model, Front Inc. could produce a curtain wall system that was very different



**FIGURE 9-6-9** Shop drawing of a mega-panel.

Image provided courtesy Ateliers Jean Nouvel and Front Inc.

from the design proposal provided by Jean Nouvel but using the same parametric assembly. Front Inc. foresees that an emerging catalog of these types of parametric assemblies could expedite their work in the future. Marc Simmons described the process as, “Effectively mapping the essential DNA of customized facade assemblies and deploying them to create families of highly differentiated mass-customized facades. This represents a future entirely dependent on integrated practice and fabrication.”

### ***Changing the Business Model***

Dassault Systemes’ CATIA is an integrated tool designed for companies in aerospace engineering, where the person responsible for design is also responsible for engineering, sales, and marketing. The use of Digital Project, as a product of the consortium of CATIA and Gehry Technologies, could have similar ramifications in architecture, engineering, and construction in a design-build paradigm.

As a result of this experience, Front Inc. has broadened its services beyond consulting for owners, architects, and contractors. The company is working with architect Point B Design on a gallery project in Philadelphia, where they have designed, engineered, and are in charge of fabrication and delivery of the façade system. They are now engaged in similar deployment strategy for façades designed by Neil Denari Architects, in New York City, and Tod Williams and Billie Tsien in Amagansett, New York.

### ***The Need for a BIM Skill Set***

Front Inc. had a team of architects and engineers with various backgrounds. Although the majority of the team had received in-house training in Digital Project, Marc Simmons, the company principal, explained that one individual in particular was truly capable of using this software to its full potential at that time. Thanks to his training as an aeronautical engineer, this individual exemplified the new type of role, where the designer is also responsible for detailing and performance.

Front Inc. now looks for a different skill set in the pool of applicants eager to join the firm, with greater emphasis placed on the use of BIM technology. Recent graduates from Rensselaer Polytechnic Institute, California Polytechnic State University, and Georgia Institute of Technology seem to meet the expected level of skill and knowledge of building information modeling tools.

### **9.6.4 Conclusion**

In this project, a complex aesthetic concept for a curtain wall system was resolved in a building information model with a set of regulating lines in order to structure a hierarchical nesting of parameters bound to design tables. Visually, the effect of the regulating grid is neutralized, because of the complexity of the subdivision of the system. Therefore the legibility of the vertical and horizontal lines is reduced, and the variegated texture of the façade is emphasized.

Because this innovative curtain wall system entailed a financial risk, the ownership group looked at the contract early and asked Front Inc. to find solutions that would enable the design proposal to be realized with the lowest possible cost risk.

Building information modeling is impacting the way architects design and how buildings are constructed. Because the model becomes the central database of information, the analysis of design ideas and building performance, cost estimation, and construction scheduling can be done with greater accuracy. By using the same model, architects, engineers, contractors, and manufacturers can communicate and implement changes to the design quickly. Communication, however, is limited by two main factors that affect the BIM

process. At the basic level, not all members of the AEC team may be using the same or compatible software; therefore information is lost in the exchange of model files. In addition, for BIM tools to be used to their full capability, additional expertise and skills are required of architects and designers, beyond the limits of commonly accepted skills. In this case study, these problems were avoided because of the unique skill set of the Front Inc. team and their management of all information contained within the curtain wall design. At a more complex level, communication during the design and construction process is fragmented by other structures in place, having to do with the definition of professional roles and responsibilities within the AEC team. In this example, a different model of services was developed.

## Acknowledgments

---

This case study was prepared by Paola Sanguinetti for Professor Chuck Eastman in a course offered in the College of Architecture Ph.D. Program at the Georgia Institute of Technology, winter 2006. It has been adapted for use in this book. The authors wish to acknowledge and thank Marc Simmons and Dario Caravati of Front Inc. for providing the bulk of the information. The images are courtesy of Front Inc. (Marc Simmons, Dario Caravati, and Philip Khalil) and Ateliers Jean Nouvel.

---

## 9.7 ONE ISLAND EAST PROJECT, HONG KONG

### *Owner/Developer BIM Application to Support Design Management, Tendering, Coordination, and Construction Planning*

#### 9.7.0 Introduction

This case study documents the implementation of BIM to manage the functional and financial relationships between design, construction, and facility management on a large, complex project by an owner-developer. The owner identified the potential of BIM to manage information more efficiently and save time and cost over the project lifecycle. This case study discusses how the owner initiated the BIM effort on the One Island East (OIE) project after design using 2D tools had already started, worked closely with their design/construction team and technology team, and integrated BIM into the design

**Table 9–7–1** Summary of One Island East Project Information

Location:	Hong Kong, China
Project Name:	One Island East (OIE)
Contract Type:	Competitive tendering
Construction Cost:	\$300 million (approximately)
Project Scale:	70 Floors with 2 basement levels
Total floor area:	141,000m <sup>2</sup> (1,517,711 sf)
Typical floor area:	2,270m <sup>2</sup> (24,434 sf)
Schedule:	Period of construction: 24 months
Expected completion:	March 2008
Current Stage:	Under construction as of January 2007
Owner:	Swire Properties Limited
Architect:	Wong & Ouyang (HK) Limited
Quantity Surveyor:	Levett & Bailey Quantity Surveyor Limited
Contractor:	Gammon Construction Limited
BIM Consultant:	Gehry Technologies
Functions:	Office and Commercial Facilities
Structure:	Reinforced Concrete
Exterior:	Aluminum Curtain Wall

and construction of the project. The study discusses training of the project team in the Digital Project BIM software to support design, clash detection and correction, quantity takeoff and tendering, coordination of the team, and 4D planning.

Swire Properties is one of the top developers and industry leaders involved in the construction industry's transformation in Hong Kong. One of their projects, OIE, is a large commercial office building with 70 floors that is currently under construction in Hong Kong. Table 9–7–1 provides an overview of the basic project information. Figure 9–7–1 shows a computer rendering of the planned office building. As an owner, Swire's organization is responsible for managing the design and construction and the leasing and operations of the facility. In addition to this facility, Swire manages hundreds of facilities or projects at any given time; and was seeking better tools to both oversee and coordinate the design and construction process and potentially link the building information to their facility management systems. In particular, Swire was looking for a building management tool capable of managing a very large

**FIGURE 9-7-1**

Computer rendering of the proposed building.

Image provided courtesy of Swire Properties, Inc.



project or several such projects with the capability to link design information, cost and schedule data, construction process management, quality assurance, and facilities management.

Furthermore, as part of their commitment to improving the quality of their buildings, Swire recognized the potential of BIM to increase the quality control and efficiency of their buildings over the entire facility lifecycle.

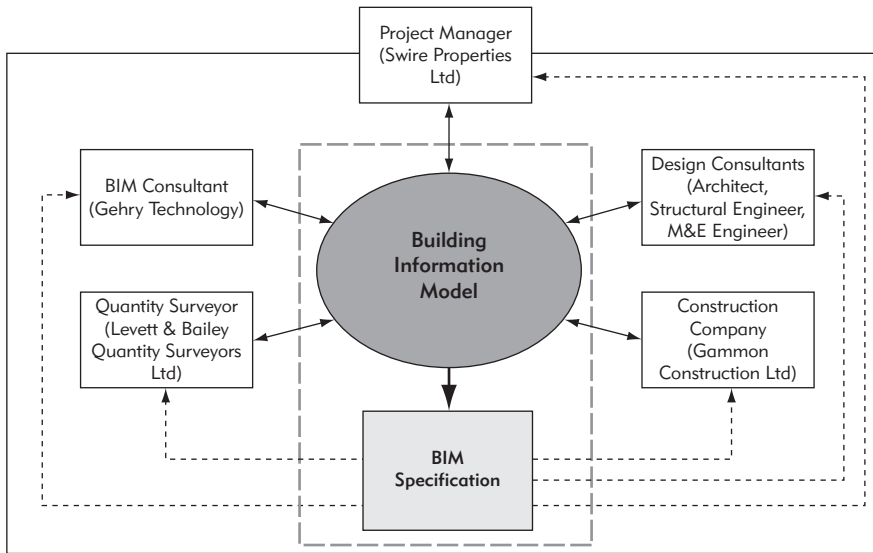
### 9.7.1 Pretender Stage BIM Implementation Process

The OIE project was in schematic design phase when Swire was researching BIM systems. They attended a presentation by Gehry Technologies (GT) together with the Hong Kong Polytechnic University held in early 2004 where the Swire team saw a demonstration of Digital Project (DP) software. After serious consideration, Swire Properties adopted Digital Project as their companywide BIM management tool in February 2005. The DP system was designed to support large, complex projects and manage relationships to various information sources such as cost, construction, and facility management.

At the time of DP adoption the OIE project team was performing schematic design with traditional 2D drawings. The four key project organizations were already on the project:

- The design consultant team consisted of the architect, the structural engineer, the mechanical and electrical engineer (M&E), and the quantity surveyor. Wong & Ouyang Hong Kong Limited led the design.





**FIGURE 9-7-2**  
Integration of BIM within  
the project team.

Image provided courtesy of  
Swire Properties, Inc.

- Structural design was provided by Ove Arup & Partners, Hong Kong Limited.
- Meinhardt (M&E) Limited was responsible for the M&E engineering design.
- Levett & Bailey Quantity Surveyor Limited was responsible for all aspects of cost control.

Initially, these four companies, which comprised the design consultant team, communicated with each other using 2D drawings but subsequently developed a full 3D process using DP's BIM software as shown Figure 9-7-2. To expedite the process, GT provided BIM consultancy services and led the BIM implementation and training.

The building information model was initiated by Gehry Technologies, who then trained the design consultant team for three weeks. The actual modeling team consisted of architects, structural engineers, MEP engineers, and quantity surveyors. After becoming proficient in the use of DP, the design consultant team took over the BIM process and completed the building model. GT and the design consultant team cooperated closely in this effort.

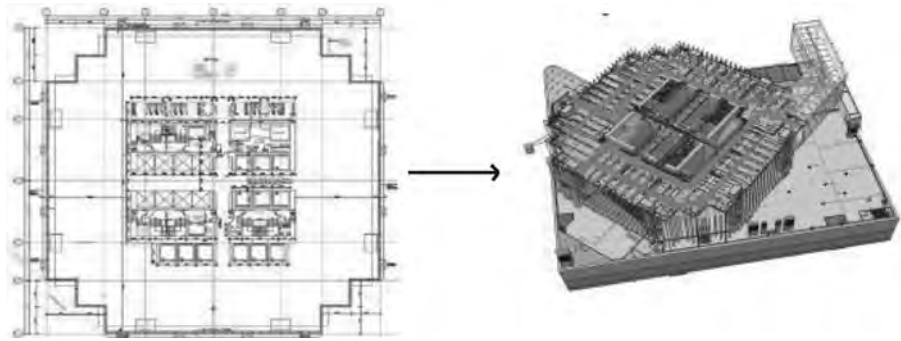
### ***Creation and Coordination of the Building Information Model***

Almost all coordination issues were managed using BIM. The BIM consultant team, the OIE design team, and the project manager worked in one room for

**FIGURE 9-7-3**

Translation from 2D to 3D.

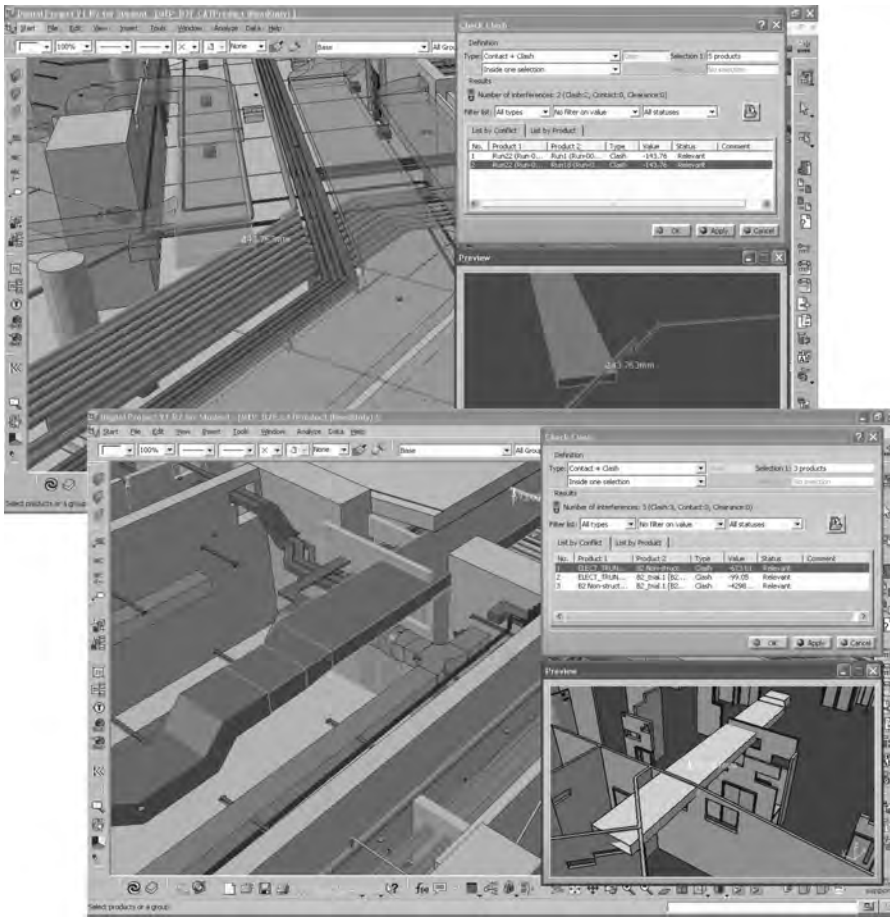
Image provided courtesy of Swire Properties, Inc.



the first year. The design team consisted of four architects, four structural engineers, six MEP engineers, two quantity surveyors, one project manager, one MEP project manager, and four GT BIM consultants. Everyone involved worked either directly or indirectly on coordinating the input of information into the building model. Project team members also communicated with each other through a portal site maintained by Swire Properties, which became the main communication platform for the BIM process. Project information that was not contained directly in the BIM was delivered and shared through the portal. The BIM implementation team met weekly for the first year to identify and resolve errors, clashes, and other design problems using the BIM.

In practice, many unofficial coordination meetings also took place, because the team was located in the same workspace. A number of clashes and errors were identified and managed before tendering and construction. Figure 9-7-4 shows how the clashes between elements of different disciplines could be identified easily in the 3D model. Clash detection was mainly achieved using functions contained within the DP software, which is able to identify geometric clashes and automatically generate a list. Double-clicking on an item in the list takes the user to the virtual geometric location of the clash. The structure is then corrected and redesigned by the appropriate project team member. The user can specify the tolerance of the clash-check, and this clash tolerance can be designated as the standard.

Traditionally, clashes are identified manually by design consultants using overlaid drawings on a light table. Correspondingly, in the past, a great deal of clash detection and management was left to constructors. Through BIM, over 2,000 clashes and errors were found prior to tendering and construction, which means that a substantial cost savings was achieved, compared to the incomplete design information inherent in a traditional 2D process.

**FIGURE 9-7-4**

Examples of automated clash detections.

Image provided courtesy of Swire Properties, Inc.

### **Organization and Structure of the Building Information Model**

This section describes the way information was structured using Digital Project.

A typical building information model can consist of hundreds or even thousands of parts (referred to in Chapter 2 as an object or building component). A part can be a wall, columns of a floor, an escalator, or an HVAC run. Another type of file, called the *Product Structure*, is used to organize these parts within a hierarchical structure (also called a tree structure). This approach has several powerful implications:

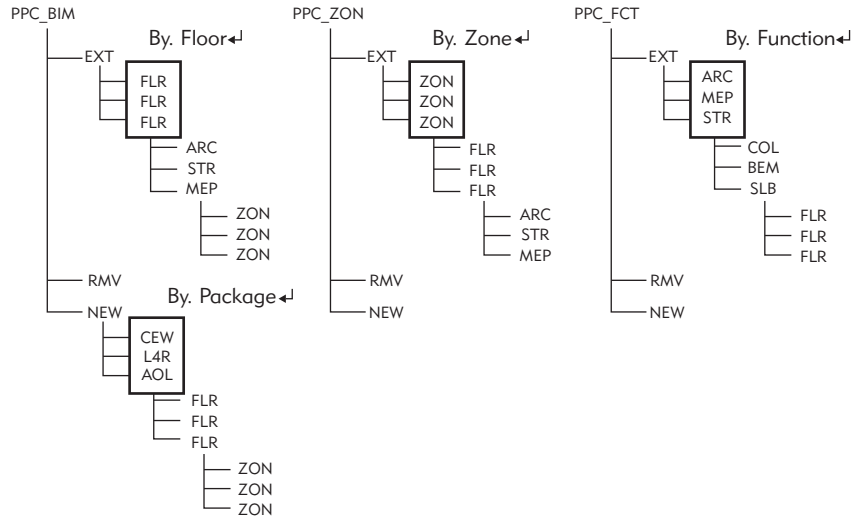
- One can open the entire building model or just one branch of it. An example would be a floor of a building or a building service system, such as HVAC or Drainage.

**FIGURE 9-7-5**

BIM database structure.

This figure shows that files can be organized in multiple ways: by floor, by HVAC zone, by function, and by construction package. The same part file can be referenced in multiple product structures.

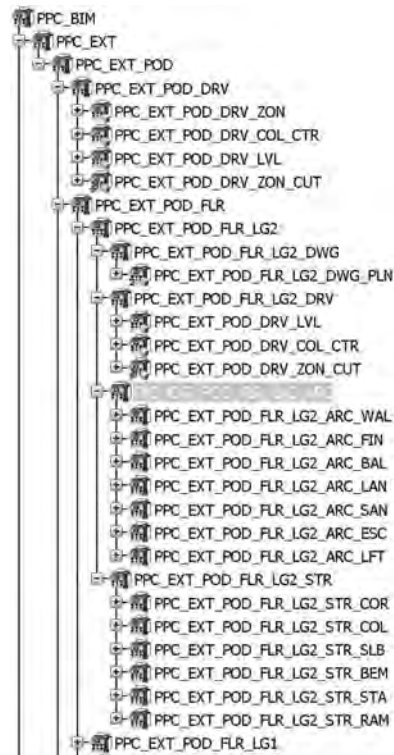
Image provided courtesy of Swire Properties, Inc.



- Large teams can work on the same DP master-model concurrently, because each file is an autonomous entity. Modelers can use a tool called Concurrent Versioning System (CVS) to manage file permissions for modelers.
- It is possible to load a part from different Product Structures. For example, one can create a tree to load the building floor-by-floor and at the same time create another tree organized by function (Figure 9-7-5).
- Parts files can be interlinked and therefore influence each other's geometry in a parametric way.

A detailed example of a typical project tree-structure is shown in Figure 9-7-6.

A typical BIM model is structured in a way that has the main building parts, such as PODIUM and TOWERS, e.g., POD, T01, at the highest level. Each main building part is then organized by floor and also contains branches for parts that are not floor-specific. Examples of the latter are the branches for the main driver files, lift cars, and section drawing files. Driver files contain information for details, such as column centers, floor-level planes (e.g., Finishing and Structural Floor Levels, SFL & FFL, respectively), and zoning cuts (for terminating columns and beams that extend beyond each zone). The parametric nature of DP allows one to change a floor level and automatically update all of its related geometries. Driver elements are published and thus made available as linkable objects. Each floor contains five sub-branches: (1) a branch with floor-specific drawing files, such as plans; (2) a branch containing

**FIGURE 9-7-6**

BIM data structure for the Podium showing the tree structure for this part of the building.

Image provided courtesy of Swire Properties, Inc.

driver files called DRV; and (3–5) three sub-branches that contain the actual geometry. There is a branch for architectural elements: walls, finishes, balustrades, landscape elements, sanitary, escalators and lifts; a branch for structural elements: core walls, columns, slabs, beams, stairs and ramps; and a branch for MEP elements: HVAC systems, drainage pipes, and the like.

The current OIE BIM model is approximately five gigabytes in size. It opens easily on a laptop, and there are no data management problems. Information is organized properly, and only material that is being worked on is opened and shown in full detail so that it can be updated. Items surrounding the item being worked on are shown grayed out and in less detail using *Computer Graphic Representation* (CGR). This reduces data size but can still provide clash detection and measurement information.

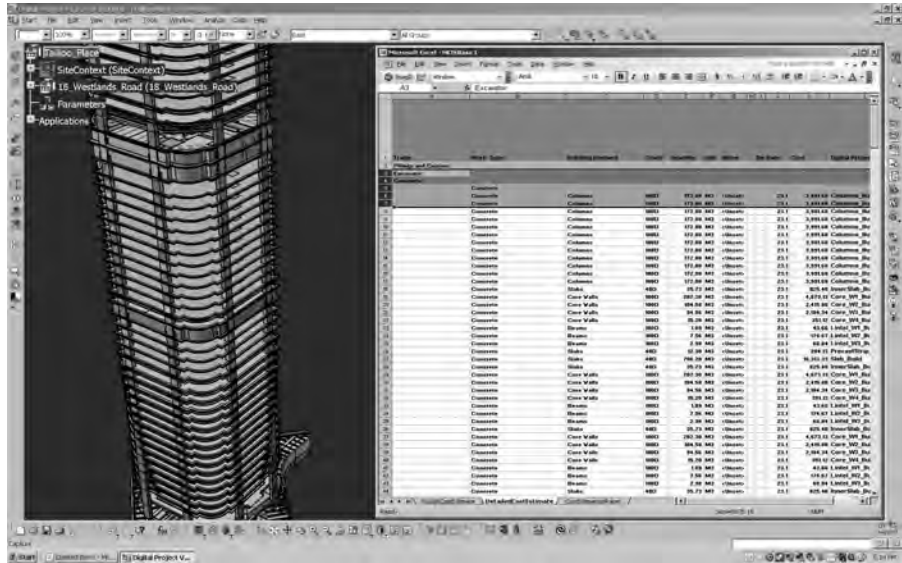
### Tendering

DP's BIM tool measured many of the quantities automatically; however, the quantity of reinforcing bar in the structure was calculated manually using the ratio of rebar to concrete. DP could have provided this capability if the

**FIGURE 9-7-7**

Automated quantity takeoff for the generation of the bill of quantities in Excel format.

Image provided courtesy of Swire Properties, Inc.



rebar had been modeled explicitly. All elements modeled in the BIM process included their own attributes, such as size, weight, area, volume, and so forth. Such quantitative information was tabulated automatically and imported into the Excel spreadsheet shown in Figure 9-7-7. This approach increased accuracy and reduced the effort and time usually required for manual quantity takeoff. Furthermore, the quantities were linked to the BIM, which enabled them to automatically update when the design changed. The BIM model was provided to all of the tenderers, enabling them to confirm the bill of quantities firsthand using the model. This improved the tender process and resulted in lower cost estimates and reduced risk.

Tendering for the OIE project was greatly improved by precise quantity extractions from the BIM. Construction companies that bid on the OIE project saved time and money because they did not need to measure the quantities manually. The increase in accuracy of quantity takeoffs also helped the quality of construction and reduced the contractors' risk. BIM was used to track the cost implications of contemplated changes onsite. Designers and engineers could easily coordinate with each other by checking all elements using 3D BIM (Figure 9-7-12(A) through (C)), which has traditionally been a difficult process using 2D drawings.

### 9.7.2 Post-Tender Stage of the BIM Implementation Process

At the time of writing, nearly one-half of the 24-month construction program had passed, and the structure had progressed on schedule (see Figure 9-7-8).

**FIGURE 9-7-8**

Site progress as of January 2007.

Image provided courtesy of Swire Properties, Inc.

After tendering, the contractor's construction BIM model was updated by Gammon Construction Limited. A substantial amount of additional information regarding construction objects, such as formwork and other temporary structures, was added by the contractors. Of course, the model is in accordance with the pretender design intent. Gammon has realized the added value of using BIM technology in construction.

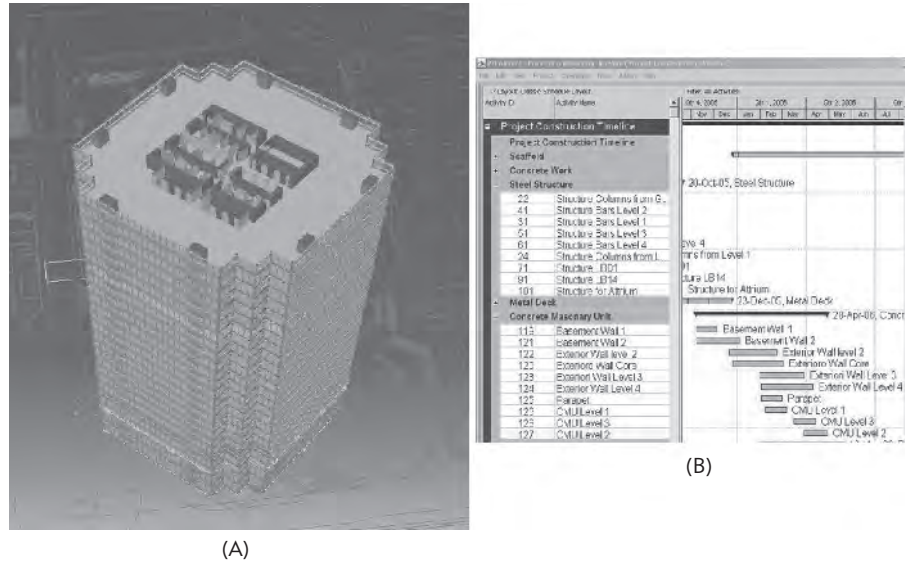
By using the BIM elements developed by the design consultant and contractor project teams, advanced construction process modeling was also carried out to further verify the construction methodology. Gammon Construction Limited called upon the expertise of the Hong Kong Polytechnic University's Construction Virtual Prototyping Laboratory, led by Professor Heng Li, to produce detailed visualizations of the construction sequencing. Links were created between DP's BIM elements and the detailed Gammon Primavera construction schedule (see Figure 9-7-9). This enabled the visualization of a construction sequence which was a helpful tool for the contractor, called 4D CAD (see Figure 9-7-10). Visualizations of the sequence of erection of building elements could be created easily, according to the Primavera early- or late-start sequence. In this way, Gammon was able to visualize and analyze various

scenarios; and spatial/safety issues could be identified prior to construction (see Figures 9–7–11 and 9–7–12). For example, the sequence of formwork erection for a typical floor was checked and rechecked to ensure that a construction cycle of four floors per day could be maintained. The construction methodology for the

**FIGURE 9–7–9**

Schedule integration and visualization.

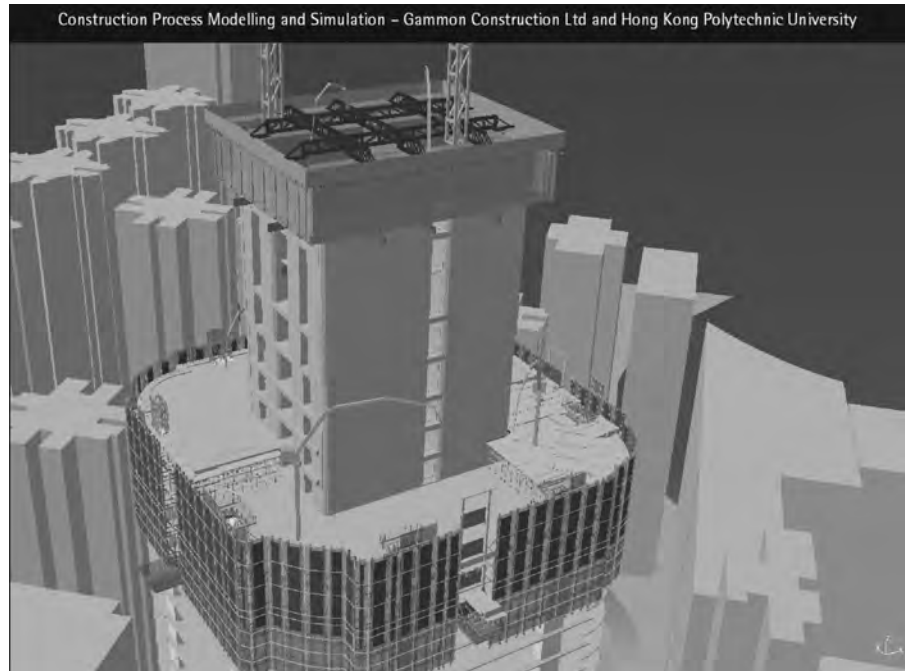
Image provided courtesy of Gammon Construction Ltd., and Professor Heng Li at Hong Kong Polytechnic University.



**FIGURE 9–7–10**

Illustration of the construction sequence. (See color insert for full color figure.)

Image provided courtesy of Gammon Construction Ltd., and Professor Heng Li at Hong Kong Polytechnic University.





difficult outrigger floors was carefully examined to ensure safety and practicality. This saved time and money in the field.

### 9.7.3 Conclusions and Lessons Learned

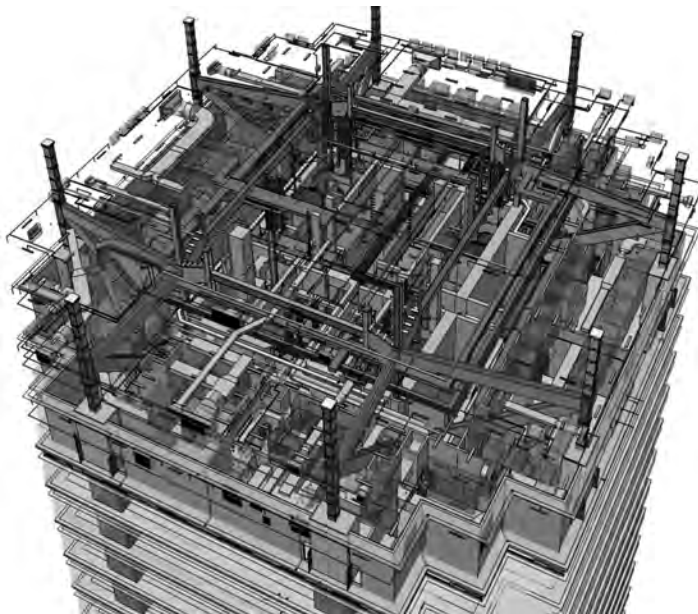
One of the main challenges for the project team was transitioning from 2D to 3D. Swire Properties mitigated potential cultural issues by requiring the use of



**FIGURE 9-7-11**

Illustration of clash detection.

Image provided courtesy of Gammon Construction Ltd., and Professor Heng Li at Hong Kong Polytechnic University.

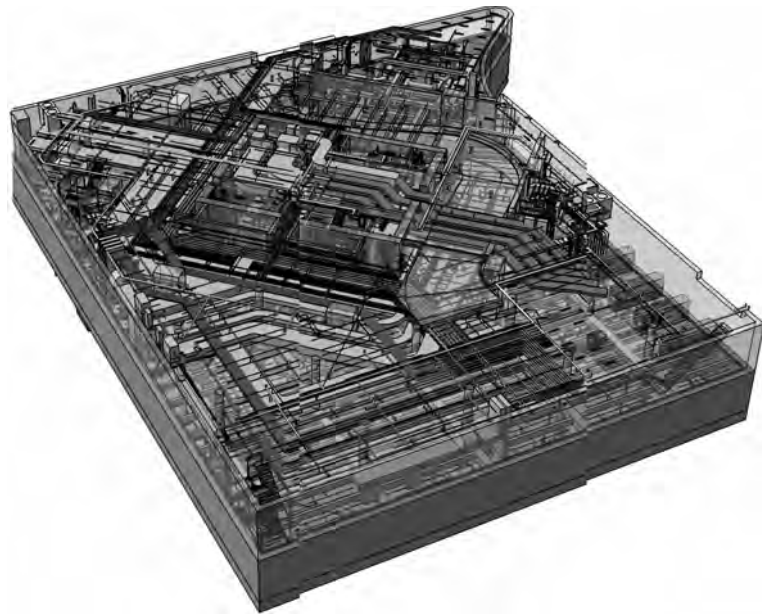
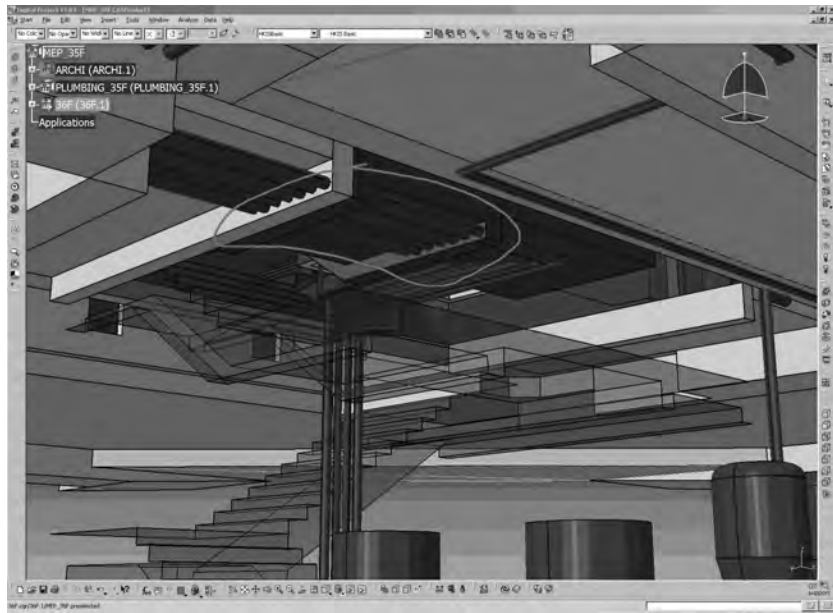


**FIGURE 9-7-12**

Three-dimensional coordination of all project elements. (A) Structural and MEP elements at a typical floor level (see color insert for full color figures.); B) Piping in basement area under ground level; C) MEP elements in the basement levels of the building.

Image provided courtesy of Gammon Construction Ltd., and Professor Heng Li at Hong Kong Polytechnic University.

**FIGURE 9-7-12**  
(Continued)



3D and the DP system on the project. Furthermore, Swire hired Gehry Technologies as a consultant to provide the adequate training and support during the first year of the BIM effort. In the future, Swire Properties hopes to achieve even greater value when the BIM technology and working methods are implemented from the very beginning of the process.

A second critical lesson is to select a BIM application and system appropriate for the type of projects and business goals of an organization. Swire carefully reviewed and assessed technologies based on their long-term organizational needs. Since Swire builds large, complex facilities, the selection of DP was critical both in supporting their long-term investment as well as ensuring that their project team would not face daily issues with managing model size or complexity.

As of the writing of this case study, the post-tender stage is not yet complete, so it is impossible to quantify all of the benefits and problems associated with BIM implementation in this phase. At this point it is possible to say that there have been significant savings in cost and time resulting from the reduction in design errors found by clash detection. The careful 4D analysis performed by Professor Heng Li's group provided assurance that a fast and safe schedule could be achieved. Quantitative information, such as the number of change orders, safety records, budget performance, schedule performance, and so forth will ultimately help measure the value added by the use of BIM.

## Acknowledgments

This case study was originally written by Sung Joon Suk and Martin Riese for Professor Chuck Eastman in a course offered by the Design Computing Department at the Georgia Institute of Technology, winter 2006, and has been adapted for use in this book. The authors wish to acknowledge the assistance of Swire Properties Inc. and Gehry Technology in the preparation of this study.

---

## 9.8 HELSINKI MUSIC CENTER

### *Advanced Environmental Assessment and Sustainable Design*

#### 9.8.1 Project Description

The Helsinki Music Center aims to give Finland's capital city an outstanding and acoustically exceptional concert hall, along with other facilities enhancing the musical experiences for people of all ages. Helsinki Music Center is located in the city center just in front of the Houses of Parliament. The closest neighbors are Kiasma Museum of Contemporary Art and the main building of

**FIGURE 9-8-1**

Rendering of the Helsinki Music Center.



*Helsingin Sanomat*, Helsinki's major newspaper. The main users of the building will be the Sibelius Academy, the Helsinki Philharmonic, and the Finnish Radio Symphony Orchestra. It will also serve as a place to study music.

Outside the hall is a light-filled foyer with glass walls (see Figure 9-8-1). The capacity of the main concert hall is 1,700, with an audience surrounding stage arrangement. The building will also house five smaller auditoriums, each seating 140 to 400 people for performances from chamber music to jazz to electronic pieces. In addition, the building will house the Sibelius Academy, coffee shops, and a restaurant. The building's total floor space is 36,000 square meters (387,500 square feet). It is set to open in 2011. It is in the construction stage at the time of this case study writing.

The current concert hall, Finlandia, was built by Finland's most famous architect, Alvar Aalto, in 1971. While the building was magnificent, its acoustics were not. The Music Center was initiated to fix that mistake. In planning the acoustics of the new Music Center, nothing has been left to chance. When LPR Architects won the design contest in 2000, their contract included an agreement to design the spaces in cooperation with Japanese consultants Nagata Acoustics.

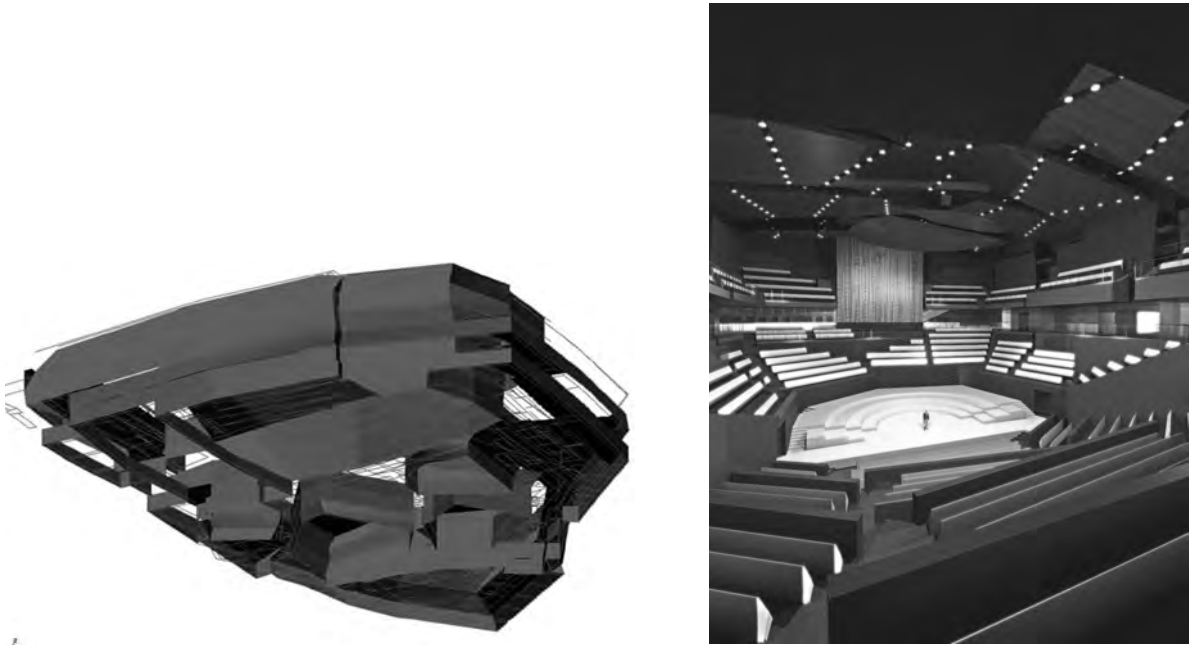
In the corner of the construction site closest to the railway station there is 1:10 model of the concert hall on display (see Figure 9-8-2). Miniature figures

**FIGURE 9-8-2**

One-tenth scale model of the concert hall, by Nagata Acoustics.

sit on the benches, with clothes and hair that mimic those of a real audience. This model has helped the acoustic consultants make exacting studies of the way sound behaves in the concert hall, forming the basis of the plans, various seating terraces, and the dramatic shape of the ceiling. Using the one-tenth scale model, filled with nitrogen, and monitored with an array of audio sensors, the terrace-style layout of the concert hall, without the usual side reflecting walls, can be tuned to provide excellent acoustics, reports Yasuhisa Toyota, president of Nagata Acoustics. Nagata Acoustics were the acoustical advisors for many of the leading new concert halls, including Disney Hall in Los Angeles and the Copenhagen Symphony Hall.

The State of Finland, the City of Helsinki, and the Finnish Broadcasting Company jointly held a two-stage international competition for the design of the project. From the 234 entries, the project was awarded to an entry entitled “a mezza voce” by architects Ola Laiho, MikkoPulkkinen, and Marko Kivistö in the year 2000. The music center embraces Scandinavian design, with clean, functional spaces. The exterior uses patinated copper to visually link with the green copper roof of nearby Finlandia Hall, and a glazed glass foyer surrounds the concert hall. The auditorium itself features double-paned, insulated glass walls on the main floor, allowing people inside the hall to see out to the foyer and into the park in front. A curtain between the glass panels can also be shut during performances.



**FIGURE 9-8-3** Computer building model of the concert hall shell, courtesy of Giencke and Company. This model was refined by Nagata, then fitted within the AutoCad Architecture model by LPR Architects. Integration is shown in the image on the right.

The architect won the architectural competition for the project in 2000. The competition work was done in the traditional way, using drafting techniques, renderings, and physical models. The preliminary design was submitted for review and the cost estimate came in significantly over budget and the project was stopped. The project was significantly revised, but still with the spirit of the original prize-winning entry. The architect began again, in August, 2004, this time using BIM. During the schematic design phase (August 2004 to April 2005), the old 2D drawings that were prepared for the competition were converted into a 3D model, using first Architectural Desktop, which on later releases evolved into AutoCAD Architecture. The model was enhanced and refined by the architects working directly in 3D with modeling continuing through the detailed design phase (see Figure 9-8-3). The model will also be used later for facility management.

Like many concert halls, The Helsinki Music Center's concert hall was "a highly tuned musical instrument" designed separately and wrapped inside the outer building shell. In this case study we focus on the rest of the building, especially on the environmental analyses that were applied to refine the design.

### 9.8.2 BIM Development and Application in Finland

The necessity for incorporating sustainable strategies using BIM is growing quickly in Finland. Senate Properties, the owner of this project, is Finland's largest property asset manager (the Finland's equivalent of GSA in the United States). It has established BIM standard guidelines for construction to stimulate sustainable development. In environmental operations, Senate Properties' main focus is to achieve a considerable reduction in the energy consumption of current property assets and minimize the environmental impacts of new construction. Since 2001, Senate Properties has worked on a number of pilot projects to widen their knowledge and scope of using building information modeling. Based on the lessons learned from these pilot projects, they have evaluated BIM technology that is adequate for being put to use in ordinary projects. The organization has decided to require all of its projects to meet IFC standards. The main aim of modeling is to ensure that the scope, cost, and practicality of the project matched with the objectives. Multiple applications and models were used to obtain high levels of human comfort and energy efficiency.

### 9.8.3 Project Team of Helsinki Music Center

The project organization was somewhat unique (see Table 9–8–1). The acoustic consultants were picked first, and the architects were selected through the competition. The architects, LPR, and acoustic consultant, Nagata Acoustics, reported

**Table 9–8–1** Project Team

Role in the Team	Name
Owners:	State of Finland, Senate Properties, City of Helsinki, YLE national public broadcasting company
Lead Developer:	Senate Properties
Construction Manager:	ISS
Architect:	LPR-arkkitehdit Oy
Acoustical Engineer:	Nagata Acoustics Inc./Yasuhisa Toyota
Structural Engineer:	Mikko Vahanen Oy
HVAC Engineer:	Olof Granlund Oy
Electrical Engineer:	Lausamo Oy
Construction Company:	SRV
Structural Steel:	Peikko Group
Curtain Wall Panels:	Normek Oy

to the lead developer (Senate Properties), along with ISS, the project management consultant. The various other design consultants reported to LPR. The construction contract was assigned to SRV when the project was near design completion. The subcontracts were received through an open-bid process from a wide set of EU-based companies. In U.S. terms, the project was design-bid-build.

The owner, Senate Properties, has been motivating the use of BIM on this and all other projects. The main purpose behind BIM adoption was the integration of the processes and workflows of all the team members, across all phases of the project.

The architect focused on improving on the efficacy and competency of the architect's own working process. Three main clients of this music center will be the Sibelius Academy, the Helsinki Philharmonic, and the Finnish Radio Symphony Orchestra. During the schematic design phase, the architectural design changed frequently owing to the users' requirements and owner's cost target. The architects used BIM to calculate the floor area usage and generated the area distribution report for the main occupant groups, sometimes as frequently as every 15 minutes. The floor area distribution reports helped in guiding design decisions with regard to spatial allocation among the tenants and to determine preliminary cost estimates. It was thus very important to generate up-to-date and accurate area distribution reports. A second area of focus involved the quality of the architect's models and drawings. Because these renderings are passed on to the client and other team participants, it is critical in a BIM process that all parties be efficient and knowledgeable of the other team members' modeling and data needs. In order to do this, the architects were challenged to increase the depth of knowledge in other fields like MEP design and field construction, in order to effectively manage the information from other disciplines that were inserted in the model.

The model-based analysis by the acoustics engineer, Nagata Acoustics, had a considerable influence on the interior architectural design. The concert hall itself was designed separately, driven by acoustic considerations. The acoustic engineers checked and validated the design steps of the architects. They initially relied on computer modeling of the concert hall and its interior components. However, current computer simulation capabilities are imperfect and do not catch the behavior of sound wave dispersal at different frequencies. After this stage, Nagata then built a tenth scale model to assess the reverberation and reflection of the sound at different frequencies (see Figure 9–8–2). This facilitated better definition and quality of the sound reflection over the aural spectrum. The acoustic designer also collaborated with the interior design team to ensure that the ceiling shape, seating arrangement, and materials fit the acoustical design and did not impact the acoustical performance. The



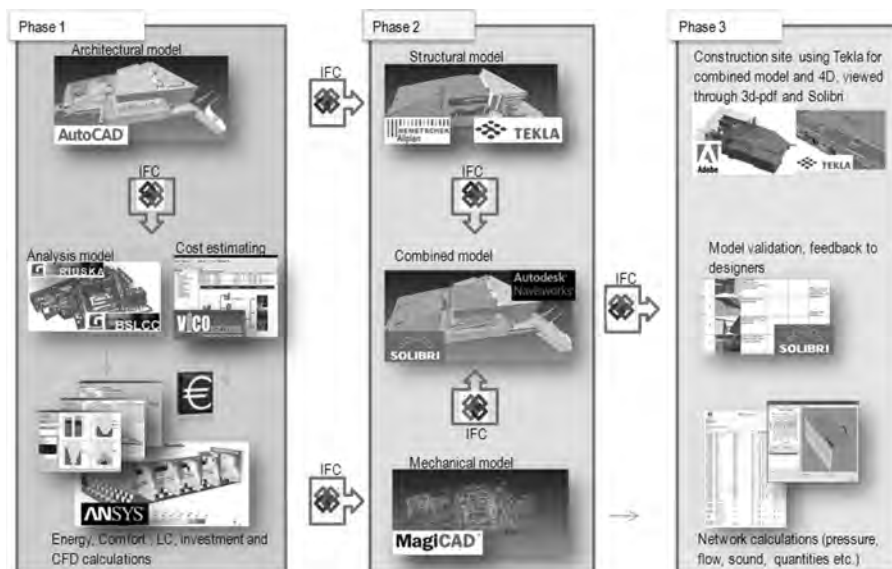
physical model also led to many fine-tuning adjustments. For example, the acoustics engineer recommended a tiled and faceted wall instead of a straight partition wall that was initially designed by the architect so as to improve the acoustic quality of the space.

Granlund, the MEP firm, is Finland's leading building services consulting firm and its operations are based on its own integrated BIM-based energy and building services tools, which are available commercially. These tools are reviewed below.

#### 9.8.4 BIM Tools Used in This Project

Figure 9–8–4 shows the energy and sustainability tools used in this project and the model flow process. These BIM applications included:

- First ADT, which later morphed into Autodesk Architecture—defined the 3D layout, provided project spatial coordination, and supported drawing production
- MagiCAD—performed 3D layout and sizing of piping and ductwork, based on flow requirements, and support for clash detection
- Riuska—performed energy analyses and generated flow requirements for MagiCAD
- Vico—estimated costs
- ANSYS—performed fluid flow finite element analysis



**FIGURE 9–8–4**  
Applications and their models used in the project.

- ROOMEX—assessed the space program and identified environmental, energy, and lighting requirements of spaces
- Tekla—performed structural design
- BSLCA—performed lifecycle cost assessment tool
- Solibri—supported spatial review and rule checking

### **9.8.5 BIM for Advanced Simulations**

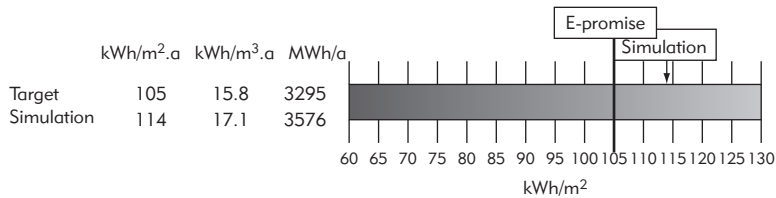
Since the data preparation requirements for energy and lifecycle simulation are very extensive, they are usually undertaken by specialized engineers or research groups at the final stage of design, in order to validate previous decisions or to fulfill legal mandates. The use of advanced energy simulation during the design process, however, also facilitated better understanding of the design problem with respect to energy, indoor air quality, thermal comfort, visual environment, and acoustical performance. But the multiple actors and complex datasets of current practice almost prohibit their use of such analyses to provide design feedback. This case study demonstrates that advanced energy simulation can be integrated with the design process. It shows how the team used the results of these analyses to modify and influence aspects of the design.

### **9.8.6 Energy Simulation at the Schematic Design Stage**

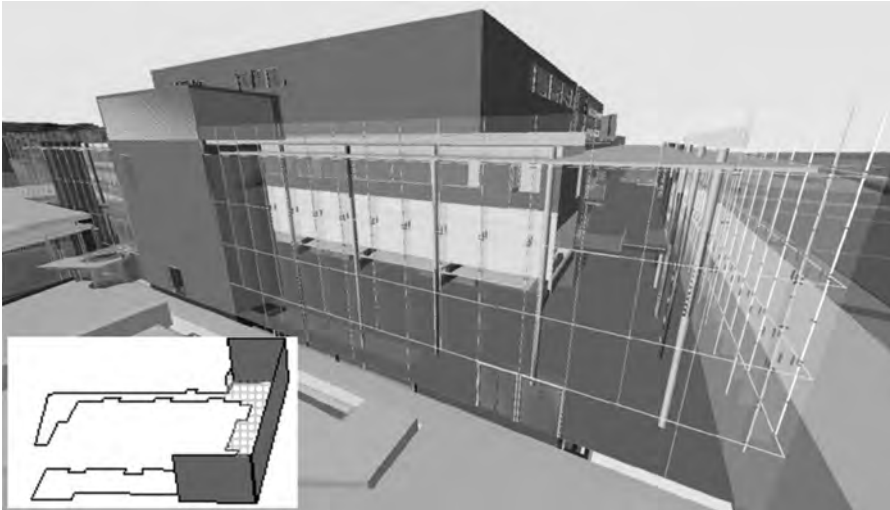
The owner established strict energy efficiency requirements and this required that the team address this aspect of design early and often in the development of the design and the acoustical aspects. A critical part of performing such analyses early is developing clear targets for performance by which the team can assess the results of energy analyses. For projects not externally restricted by energy consumption (such as a concert hall), energy simulation at the schematic design stage is helpful for the owner to set realistic energy-per-unit area targets and to estimate the operation cost. Figure 9–8–5 shows an early energy consumption simulation result and the selected annual energy usage per unit area design target. Simulation at early stages requires some assumptions based on experience or from previous similar projects. More disaggregated results from schematic design simulations can also reveal the energy consumption by each component of the building. Energy simulation was used to evaluate design alternatives; energy and cost savings were achieved while maintaining the highest quality acoustics.

### **9.8.7 Energy Simulation for Comparison of Design Alternatives**

Energy simulation makes it possible to compare different design schemes and to direct the decision-making from the point of view of energy consumption. It



**FIGURE 9-8-5**  
Schematic design energy consumption simulation results and selected energy target for use during design development.



**FIGURE 9-8-6**  
Curtain walls of Helsinki Music Center. The curtain wall façades are color coded (shaded here).

can be performed for varied systems like heating energy consumption, cooling energy consumption, electricity consumption, water consumption, and the like. For the Helsinki Music Center, Granlund evaluated several design alternatives and offered feedback to the architects by doing energy simulation at the early design stage. The following is an example that compares different glazing types for curtain walls, shown in Figure 9-8-6.

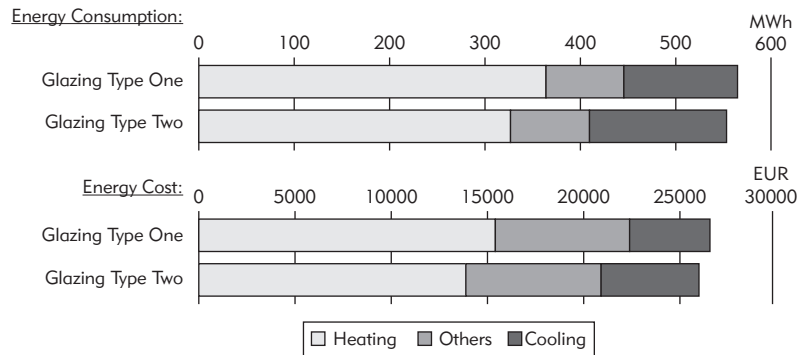
Curtain walls are very popular for commercial building design due to their open appearance as well as daylight benefits. However, parameter selection related to solar gain is difficult to determine, especially for predominantly glass curtain walls. Whether solar gain is good or not from the point of view of energy consumption relates to multiple factors, including outdoor weather condition, internal heat gain, and these vary case by case. Therefore, energy simulation is necessary for informed decision-making. Two glazing types were compared here:

Glazing Type One:

- G-value = 28 percent (total solar energy transmittance)
- ST = 16.5 percent (direct solar energy transmittance)
- U-value = 0.8 W/m<sup>2</sup> K

**FIGURE 9–8–7**

Energy consumption and cost comparison. “Others” refers to lighting and other internal energy demands (which are the same for both glazing types).



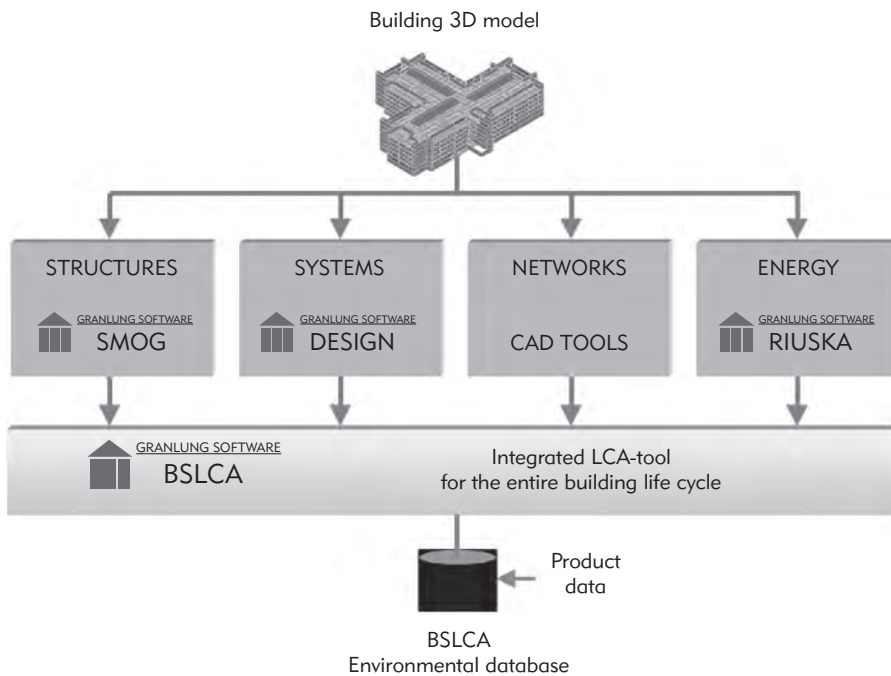
#### Glazing Type Two:

- G-value = 35 percent (total solar energy transmittance)
- ST = 32 percent (direct solar energy transmittance)
- U-value = 1 W/m<sup>2</sup>K

Riuska was the tool used for the energy simulation. It was developed by Granlund with the core of the software being the DOE 2.1E simulation energy program. DOE 2 was the main energy analysis tool in the United States until Energy Plus was released. Riuska can directly transfer the geometry data from IFC-compliant architect software, like Autodesk’s Revit and AutoCad Architecture, ArchiCAD, Nemetschek’s Vectorworks, and others. This project used AutoCad Architecture. Providing hourly simulation throughout the year, the results can be used for:

- Analysis of alternative indoor air quality levels
- Comparison of alternative windows and shades
- Dimensioning of air conditioning equipment
- Analysis of temperature problems in existing facilities

Simulation results for the glazing alternatives are presented in Figure 9–8–7. Heating energy consumption of glazing Type Two is about 10 percent lower, even though its U value is higher, because solar heat gain through glazing Type Two is more than that through glazing Type One. But for cooling, glazing Type Two results in 20 percent higher energy consumption due to more solar heat gain. For Helsinki, the heating season is much longer than the cooling season, so glazing Type Two still has a better performance based on total annual



**FIGURE 9–8–8**  
Structure of the BSLCA-  
integrated LCA tool.

energy consumption. Figure 9–8–7 also shows the energy cost comparison, which is equally important for the final decision-making.

### 9.8.8 Lifecycle Assessment Analysis

Lifecycle assessment (LCA) is a powerful method to analyze, evaluate, and compare design alternatives from a broad ecological perspective. To do so, it requires a varied set of measures over the lifecycle of the facility, for example, construction, operating and maintenance costs, energy use, water consumption, building structures, technical systems, and equipment. With a properly conceived and implemented tool, teams can make decisions applicable over all stages in the building lifecycle, from conceptual design to construction and then to facility operation and management. Measured quantities are refined over time, similar to cost estimation. Most current approaches to LCA use 2D drawings and manual entry of material and building data. They are time consuming and often performed late in the design-construction process or after the building is complete. BIM provides designers and engineers with data that can more readily integrate with LCA tools during design. BSLCA (Building Services Life Cycle Analysis) is such a highly integrated software package (see Figure 9–8–8). It links together layout and material data from the 3D building

model, system data from the building services design database, ducting and piping data from commercial HVAC-CAD tools, and energy consumption data from the building energy simulation (Laine et al. 2001). BSLCA relies on tools that can operate on building models at various levels of detail. These include SMOG, a space modeling package that addresses space and building use measures, the Systems Design tool that is linked to the BSLCA database structure to address the whole range of building services: HVAC, electrical, building automation, kitchen, and hospital equipment. The System Design tool is also used in the routine everyday design work by project engineers to save technical information into a building services database. That data includes the material for electrical, piping, and duct layout. This building systems database also forms the basic data for the facilities management system in the building operation phase. Riuska is used to generate heating, cooling, internal equipment, and lighting costs. The measures required for BSLCA can be generated by multiple external tools which are structured by the different packages into the LCA database, from which global assessments are made.

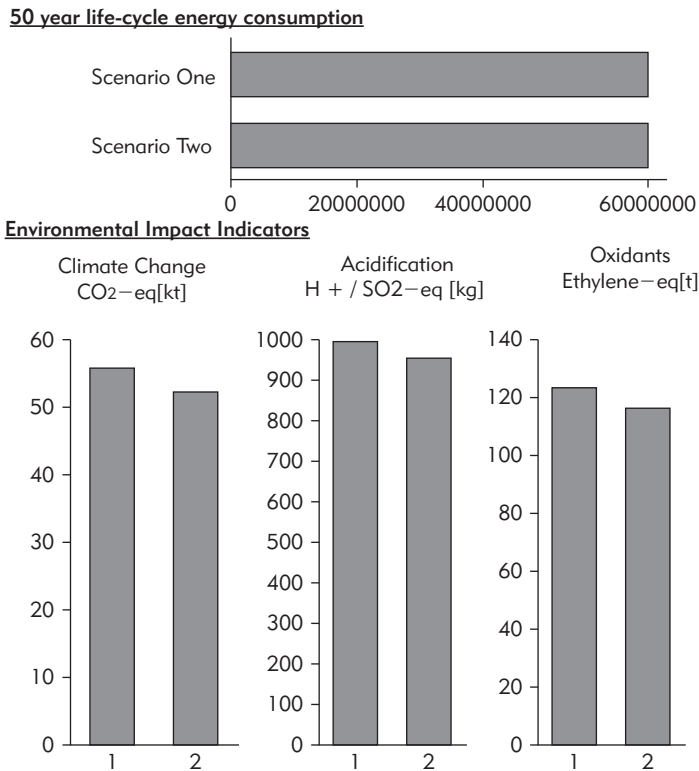
The Helsinki Music Center design team used BSLCA to compare the design against a benchmark set up for the project:

1. The benchmark design made assumptions about a typical but good project of this type and using similar methods of construction. Overall thermal energy consumption of 114 kWh/m<sup>2</sup>a; the Music Center target design was set at an overall thermal energy consumption of 105 kWh/m<sup>2</sup>a, as shown in Figure 9–8–5.
2. Scenario two consumes less energy during operation of the building, but it requires the use of more costly, higher thermal performance materials during the construction process to achieve that target. Lifecycle analysis is an effective way to balance energy consumption between building construction and operation stage.

The 50-year lifecycle results shown in Figure 9–8–9 reveal these two design schemes have similar lifecycle energy consumption, and Scenario Two has a slightly better lifecycle environmental performance.

### 9.8.9 CFD Simulation for High-Quality Indoor Environment Design

Computational fluid dynamics (CFD), as the most sophisticated airflow modeling method, can simultaneously predict airflow, heat transfer, and contaminant transport in and around buildings. These aspects can be used to evaluate the levels of thermal comfort, indoor air quality (IAQ), and building



**FIGURE 9-8-9**  
LCA analysis for comparison of two design alternatives.

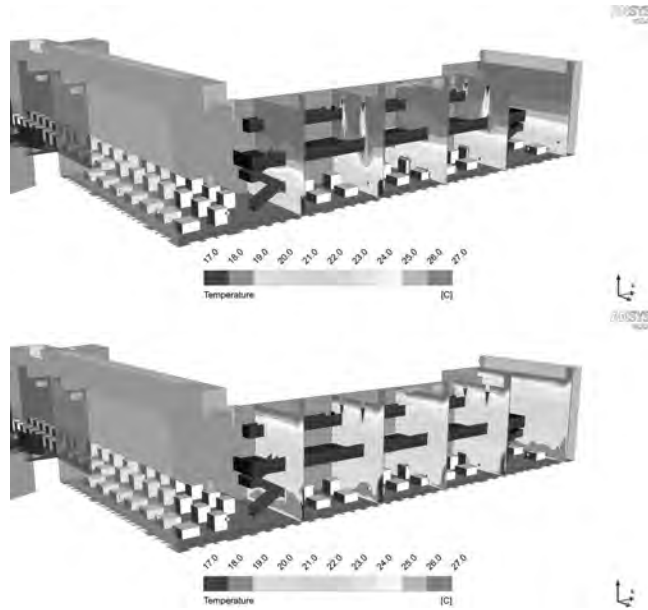
system energy efficiency, which are important to architects, to building HVAC designers, and to building consultants and researchers. The ideal way to use CFD is to assist collaboration during the design cycle of refinements leading toward the final design. CFD can be used not only as a justification or confirmation tool, but also to influence the shaping of the design. It is very useful for site planning, natural ventilation design, and HVAC system design for large spaces. However, traditional CFD simulation software is not user friendly; it is well known as complex and requires a costly process, which needs expert involvement. However, BIM can cut the amount of work to a large extent and makes CFD simulation accessible to general designers.

ANSYS® CFX was used for CFD analysis in this project. See: ([www.ansys.com/products/fluid-dynamics/cfx/](http://www.ansys.com/products/fluid-dynamics/cfx/)). The software consists of the following three modules:

- Preprocessor (geometry, computing models)
- Solver (computing)
- Postprocessor (visualization)

**FIGURE 9-8-10**

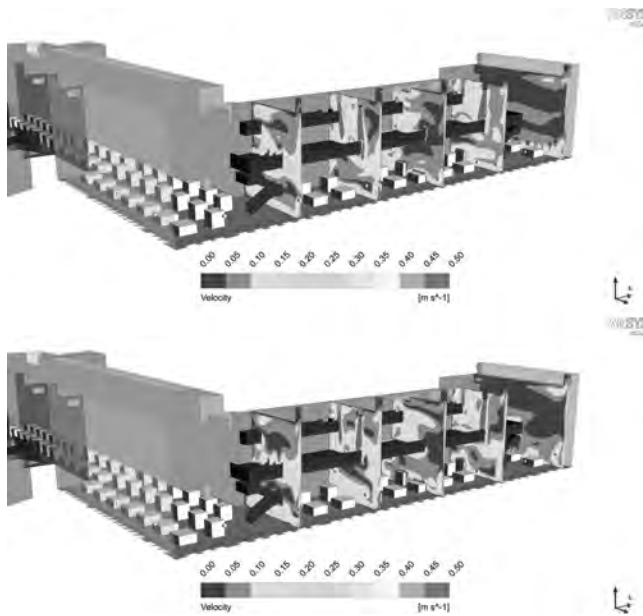
Air temperature distribution throughout the lobby area. The comfort region of less than 23 degrees was extended to include all the habitable space. (See color insert for a full color figure.)



The software is integrated with Granlund’s own BPro middleware (Karola et al. 2002), which reads the geometry from the building’s 3D model in IFC format. After this, the software determines the computing models, boundary conditions, and networks. Calculations are carried out with the solver and the results are assessed and visualized with the postprocessor. Results can also be visualized in virtual reality.

In this project, CFD was used to assess the HVAC system design. Heating and cooling load calculation software, such as DOE2.1, solves a nodal network that always assumes temperature distribution in the space to be perfectly uniform. However, for large open spaces, such as the foyer in this building, this assumption always results in a solution that requires an HVAC system that is too large. Not only does it consume excessive energy but it leads to human discomfort. Figures 9-8-10 and 9-8-11 show air temperature and velocity distribution in the lobby, in “before” and “after” conditions. (Note that the vertical sections show air flow variation and are not partitions in the open space.) In Figure 9-8-10, we can see that the initial configuration had too much heat stratification in the upper levels. In the revised design, the human-occupied zone is relatively uniform and below 23°C (73.4°F). In Figure 9-8-11, the air flow at human activity level is below 0.25 m/s in general and will not cause draft discomfort. CFD simulation was used to optimize the HVAC system. Figure 9-8-11 shows that the HVAC system at the foyer could be reduced from the top readout by over 20 percent, with little effect on the air flow distribution.



**FIGURE 9-8-11**

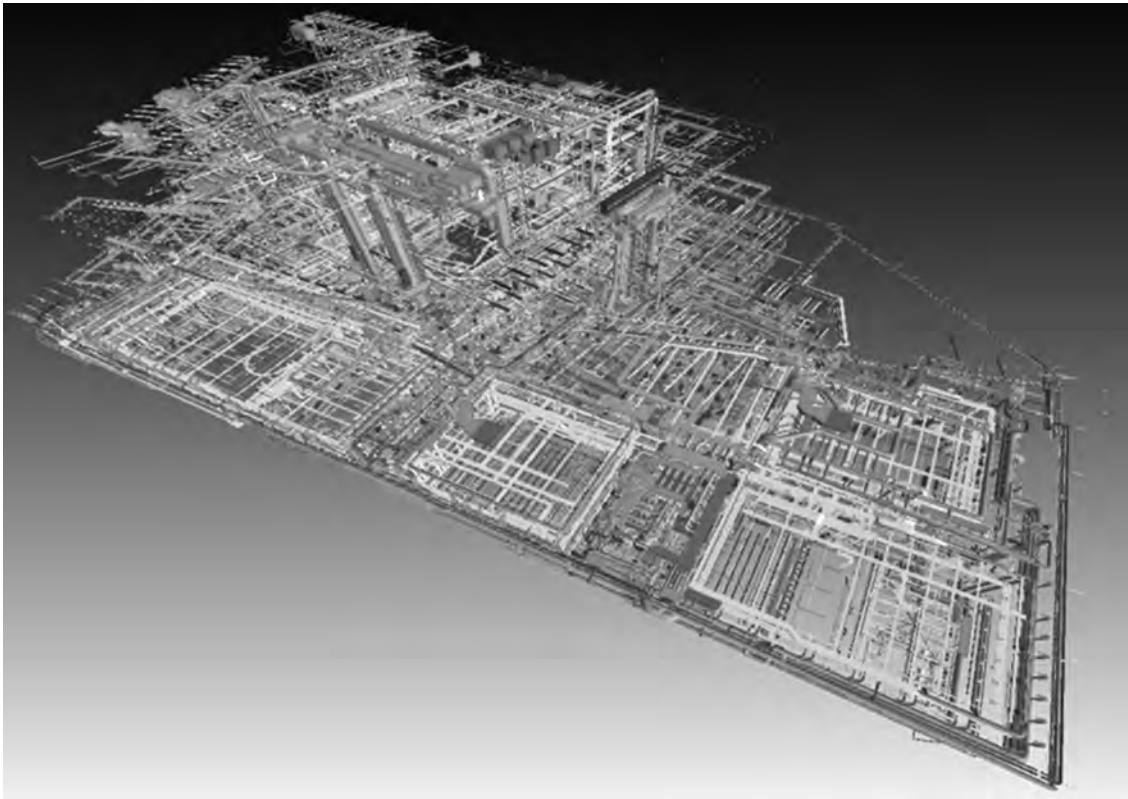
Air velocity distribution in a portion of the lobby. The second analysis results show a reduced velocity, with no negative effects. (See color insert for full color figure.)

### 9.8.10 BIM for Improving Design Quality and Productivity

#### *HVAC and Sprinkler Network Modeling*

Results from LCC analysis and CFD were entered into the MagiCAD model for MEP system design usage; energy and comfort simulations were transferred to it through IFC (see Figure 9-8-12). MagiCAD is an AutoCAD-based application used for building service design including HVAC, piping, plumbing, sprinkler, and electrical systems (Progman 2010). It is a full 2D and 3D application with integrated calculation functions for sizing, balancing, flow route examination, sound calculation, and bill of materials' organization. MagiCAD reads and writes its data from IFC, so the mechanical engineers can import and export an IFC file of the design model, complete with geometrical and technical data. MagiCAD was used in the Helsinki Music Center project for the following purposes:

- Network balancing
- Pressure calculations
- Sound calculations
- Real product data
- Bill of materials
- IFC export
- Void definitions for pass-through routing



**FIGURE 9–8–12** HVAC and sprinkler network model from MagiCAD.

### ***Combined Model for Clash Detection***

The MEP designer performed clash detection for MEP systems. Subsequently, they were examined against the Tekla structural models to detect errors. Because the electrical engineer and HVAC engineer both worked with MagiCAD, they could cross-check collisions occurring between the ventilation, piping, and electrical installations any time. MagiCAD can define void objects and pass them back to a structural model, in this case Tekla, to create openings in the structural model. In addition, Navisworks was used for visual inspections and Solibri was used for model checking/validation (floorplan area, clashes between all systems). Like other checking tools, Solibri reports the error and generates a screen image where the error takes place. The image can be transferred to a pdf for later review (see Figure 9–8–13).

### **9.8.11 BIM Flow and Interoperability Issues**

As for the advanced analysis and simulation tools, the major constraint on their everyday use at different stages of the building design process comes



**FIGURE 9-8-13**  
Combined model for layout  
and clash detection.

from time-consuming manual data input, especially related to the building geometry data. However, the continuing development of the IFC standard creates new possibilities to achieve interoperability for design software. In this project, IFC was used as the data repository for open data transfer. Olof Granlund Oy, jointly developed a middleware tool, BPro COM-Server with Laurance Berkeley Labs, MIT, and the Halton Group, for managing IFC views for mechanical systems design and analysis (Karola et al. 2002). Using this tool, the software developer was able to achieve IFC compatibility in new or existing tools with only a reasonable amount of effort (see Figure 9-8-14). It provided the information input into BSLCA, Riuska, MagiCAD, and others.

### 9.8.12 Conclusions and Lessons Learned

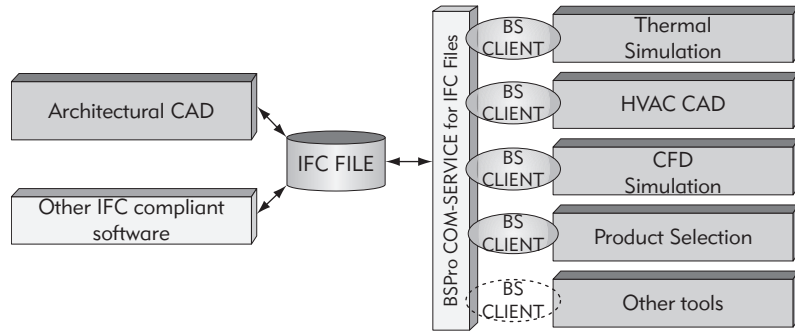
The Helsinki Music Center project offers several lessons in the application of BIM technologies.

Riuska shows how energy analysis can support design. It transfers the geometry data from architectural software to a thermal simulation geometry model, providing consistency between the two models. Its use was shown in the simulation used to evaluate the energy performance of two glazing types in the curtain wall system.

Lifecycle analysis (LCA) was demonstrated for comparing the environmental impact of design alternatives. LCA is an important type of analysis that

**FIGURE 9-8-14**

BSPro COM-Server for IFC files.



will be playing an increasingly important role in design decision-making. BIM provided the materials and energy used, extracted from the building model, and was crucial for LCA analysis.

Computational fluid dynamics (CFD) simulation is well known as a complex, time-consuming, and costly process, which requires experts to be involved. BIM cut the amount of work to a large extent and makes CFD simulation accessible to general designers. By doing CFD simulation, HVAC system loads of the foyer were reduced by over 20 percent.

By integrating a suite of analyses and simulation tools to a common IFC model view and preprocessor (BSPro), Olaf Ganlund was able to integrate a range of powerful building assessments with reasonable effort, to realize outstanding results. By using BIM, the results from energy simulation, LCC analysis, and CFD could be used in the MEP system design. The electrical engineer and HVAC engineer both worked with MagiCAD to cross-check the collision between the ventilation, piping, and electrical installations any time. This also was a benefit.

## Acknowledgments

This case study was originally written by Yuming Sun and Ameeta Dalvi for Professor Chunk Eastman in a course offered in the College of Architecture at Georgia Institute of Technology, spring 2010, and has been adapted for use in this book. The authors thank Tero Järvinen, Tuomas Laine, Reijo Hänninen, Sami Lestinen, from Granlund Oy; and Tomi Henttinen from Gravicon Ltd., Helsinki, Finland, for their assistance in providing the information contained in this case study. The authors also thank Senate Properties, Helsinki, Finland for endorsing publication of their work. Copyright release for all images, except where noted, are from Senate Properties.

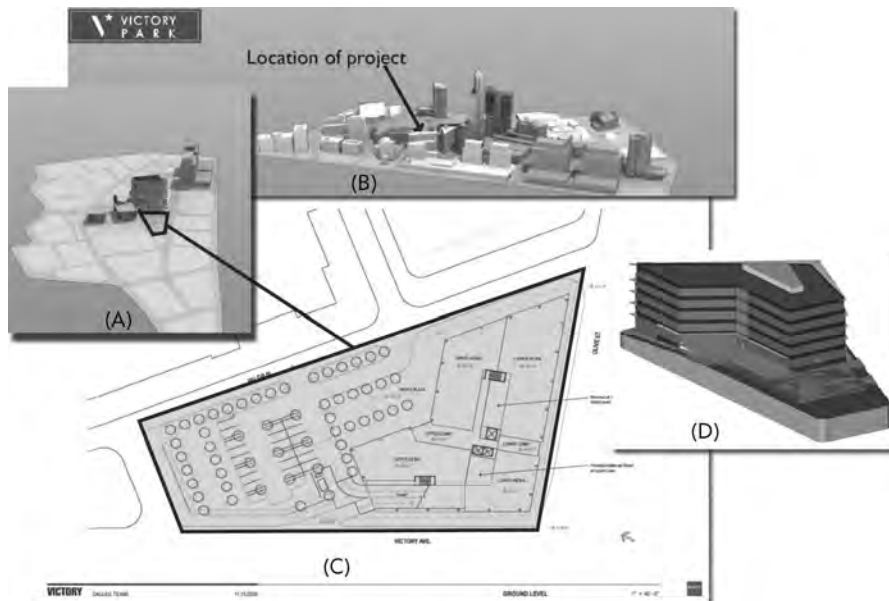
## 9.9 HILLWOOD COMMERCIAL PROJECT

### *BIM for Conceptual Cost Estimating*

#### 9.9.0 Introduction

This case study demonstrates the potential for building information models to support conceptual estimating early and often in a project and during the conceptual design and development phase. The use of parametric models by the design-builder, the Beck Group, showcases the benefits of providing informed design options to an owner early in the process and enabling both the owner and the design-build team to explore more options and, ultimately, to provide better overall design, in terms of programmatic and cost requirements.

The project is located in the Victory area of downtown Dallas, Texas, on an old railroad yard that is currently under remediation in preparation for the Victory Park Development Project ([www.victorypark.com](http://www.victorypark.com)), which includes an office-retail facility and several other buildings (see Figure 9–9–1). The owner and developer, Hillwood Development, plans to lease the retail and office space. The project was initiated in August 2006, with a lump-sum fee for design services provided by the Beck Group. As of March 2007, the project was in the schematic design phase, and lease discussions were in progress. This case study focuses on the two-month period of schematic design, when the conceptual estimating took place.



**FIGURE 9–9–1**

The project site shown in (A) 3D project site rendering, (B) 3D rendering of Victory project, (C) 2D plan view in AutoCAD, and (D) 3D conceptual rendering of building.

**Table 9–9–1** Overview of Project Details

---

Developer:	Hillwood
Architect:	Beck Group
Lot size:	1.6 acres
Office Space:	115,439 sf
Retail Space:	22,712 sf
Parking Spaces:	81
Floors:	6

---

The project is a six-story, 135,000-square-foot office-retail building on a 1.6-acre lot. The site involves unique constraints for vehicles and pedestrians, requiring accessibility changes due to the topography (see Figure 9–9–1). The Beck Group is predominantly a commercial builder with many repeat clients, and their services included conceptual estimating use of their proprietary software.

### 9.9.1 The Conceptual Estimating Process

The Beck Group provides conceptual estimating as part of its standard services for architectural design. Based in Dallas, Texas, the firm is a leading-edge design-builder on the forefront of using parametric-based CAD to support their design and building processes. In 2000, the Beck Group acquired intellectual property from the Parametric Technology Corporation (PTC) to better provide custom design services. With a small full-time team devoted to the customization and enhancement of this technology, they were able to combine their expertise in design-build with that of PTC's technology. Their initial efforts focused on supporting the quick exploration of different design options.

On this project, the Beck Group began the digital modeling effort as soon as the owner signed off on the conceptual design and prior to the schematic design phase. The Beck Group's architectural design team developed a conceptual cost model and estimate while exploring multiple design revisions and evaluating the costs associated with each of the alternative features. The iterative process involved exploration of design alternatives, calculation of cost estimates, and presentation to the client. The participants were predominantly architects from the Beck Group and the construction project manager, who provided input and guidance on constructability issues and estimating and preconstruction services. Since the Beck Group is a design-build firm, they can rely on internal knowledge. Members of both teams benefited from the multidisciplinary collaboration.

### 9.9.2 Overview of BIM Technology to Support Conceptual Estimating

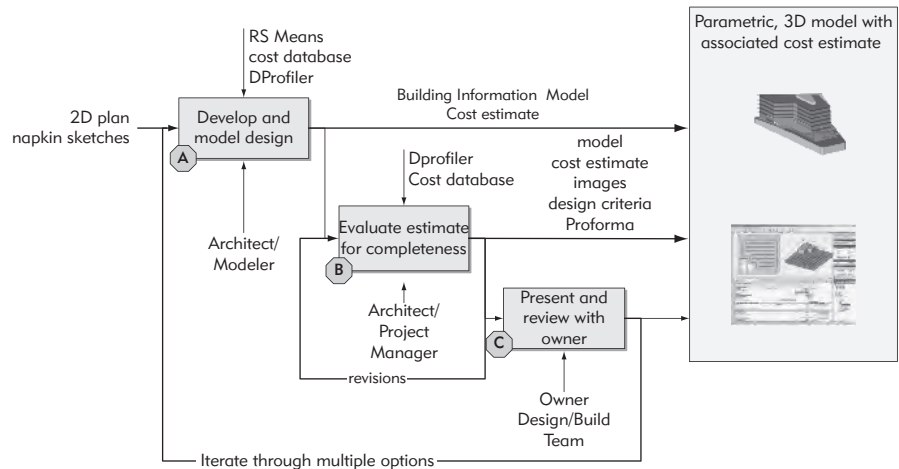
The central tool employed is DProfiler, a BIM-based solution capable of generating accurate cost estimates from a digital design model. DProfiler is a 3D parametric BIM tool that allowed the team to quickly generate a design based on specific features, parametric variables, and custom design with parametric components. The major enhancement within DProfiler, compared to other building information modeling tools, is its association with cost information.

As designers build a digital model using components from a building component library, it is possible to view real-time cost information. Each component is associated with cost items from a database. The DProfiler software package is integrated with RSMeans cost data, which includes 18,000 assemblies and more than 180,000 line items. RSMeans is a cost construction database provided by Reed Construction Data (see <http://rsmeans.reedconstructiondata.com/> for more information). This association allowed the team to quickly calculate specific features and design alternatives, allowing the owner and designer to also work in real time.

Beck's experience using DProfiler for estimating, compared to traditional manual-based estimating, has resulted in a 92 percent time reduction in producing an estimate with the digital estimating process; and an estimate with a 1 percent delta from the manual estimate on similar projects. Consequently, the design team can achieve the same results in far less time, with potentially more accuracy and the ability to explore more scenarios. This is a significant benefit for their owner clients.

### 9.9.3 Overview of the BIM Estimating Process

Once the design team had developed an initial concept, the dedicated modeler used DProfiler to create a parametric building model with links to cost items (Figure 9-9-2). A critical first step involved entering the project information including the project zip code. This allowed the team to account for regional cost factors (see Figure 9-9-3). The modeler then selected the *Building Type* that most closely resembled the project. The *Building Type* sets the project's default assumptions based on predefined parameters within the DProfiler database. The *Building Type* is basically a roadmap that links additional building components, for example, it used a template for an office building of four to six stories that included cast-in-place concrete structures and slab assemblies commonly found in this building type. Alternatively, an 8-to-24-story apartment tower with a steel frame would include steel member components. These templates were created based on the Beck Group's input and experience



**FIGURE 9-9-2** Conceptual estimating workflow using DProfiler.

It included: development and modeling of a design scenario using parametric building components and/or project templates; evaluation-based estimating using cost information associated with building components from a cost database, such as RSMeans, with insight from an experienced designer and project manager; and presentation and review of the estimated design option, involving the owner and the design-build team. This entire process can be performed for multiple design scenarios.

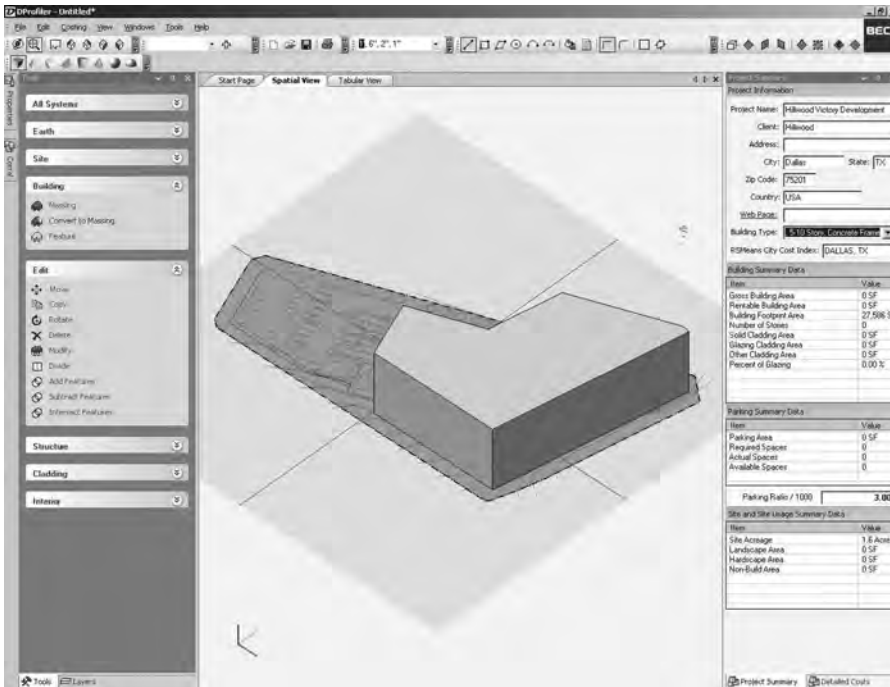
in building similar projects, as were their other 23 project templates. Organizations can develop and modify such templates based on the types of facilities they design and build.

The modeler then lays out the project site and building based on an initial concept using building components from the selected template. The modeler can import 2D plans and use them as an underlay to expedite the initial process. As the modeler creates the site or building mass, the summary data is updated in real time, as shown in Figure 9-9-3.

Each of these components or assemblies is associated with cost items in the database. As the modeler adds detail to the model, the cost estimate updates in real time and the modeler can view the estimated information, also shown in Figure 9-9-3. In this case, items are associated with information in the RSMeans cost database, but creating custom line items or assemblies is also a possibility.

These costs include line items with rules for extracting parameters from the model's components as well as for building components not represented graphically. For example, the slab assembly may include rules to account for a



**FIGURE 9-9-3**

Snapshot of DProfiler showing project information, building summary data, parking summary data, and site and site usage summary data; and showing a real-time cost estimate for the modeled design.

The cost estimate includes an overall cost-per-square-foot as well as UniFormat Level I and II cost breakdowns. Alternatively, cost can be organized using the 16 CSI (Construction Specification Institute) divisions.

fire extinguisher and cabinet for every 2,500 square feet of slab in the building. Additionally, cost line items can be associated with model parameters and variables, such as overall project square footage. These types of variables can be used to calculate the costs associated with temporary services or other less tangible building items. Throughout the modeling process, the modeler can switch between 3D model views and a detailed cost view, as shown in Figure 9-9-4.

It is important to note that the design and construction team must work together to identify such items and determine how to best incorporate them into the estimating template and components or assemblies.

The modeling process may also involve the creation of a new component or assembly representing an uncommon or unique component. For example, the shading canopy components were created from scratch for this project. This involved creating the geometry and representing the component and its associated assembly item in the cost database.

As the model is created, real-time information associated with the cost database becomes available. This type of information provides the designer with estimated costs for the current design alternative and gives the ability to associate costs with specific design features.

Building	Floor Number	Thickness	Area	Aggregate
Building1	1	7	27585.99	\$294,992.49
Building1	4	7	27585.99	\$281,826.72
Building1	2	7	27585.99	\$218,028.87
Building1	3	7	27585.99	\$318,038.87
Building1	4	7	27585.99	\$318,038.87
Building1	5	7	27585.99	\$318,038.87

Evaluation Item ID	Evaluation Formula	Name	Description	Aggregate	
1	True	Default Collection	Simple Description o...	\$0.00	
2	False	IF(FloorNumber=1, TRUE, FALSE)	Foundation System for Office, 9-10 Story	Concrete Frame	\$0.00
3	True	IF((FloorNumber > 1) && (FloorNumber <= NumberFloors), TRUE, FALSE)	Elevated Frame System for Office, 5-10 Story	Concrete Frame	\$318,038.87

Collection Items	Name	Description	Aggregate
1	E10100025	Columns for Office, 5-10 Story, Concrete Frame	\$30,159.83
2	E10100023	Plan Construction for Office, 5-10 Story, Concrete Frame	\$37,879.04

Assembly Items	Identification	Item Number	Name	Item Code	Multiple	Qty. Formula	Quantity	Cost	Unit	Aggregate
1	E10100223	6000	CP R (A2... \$10 Superstructure		1	Area	27585.99	\$18.44	S.F.	\$37,879.04
2	False	IF((NumberFloors > 1) && (FloorNumber = NumberFloors), TRUE, FALSE)	Roof Construction for Office, 5-10 Story	Concrete Frame						\$0.00

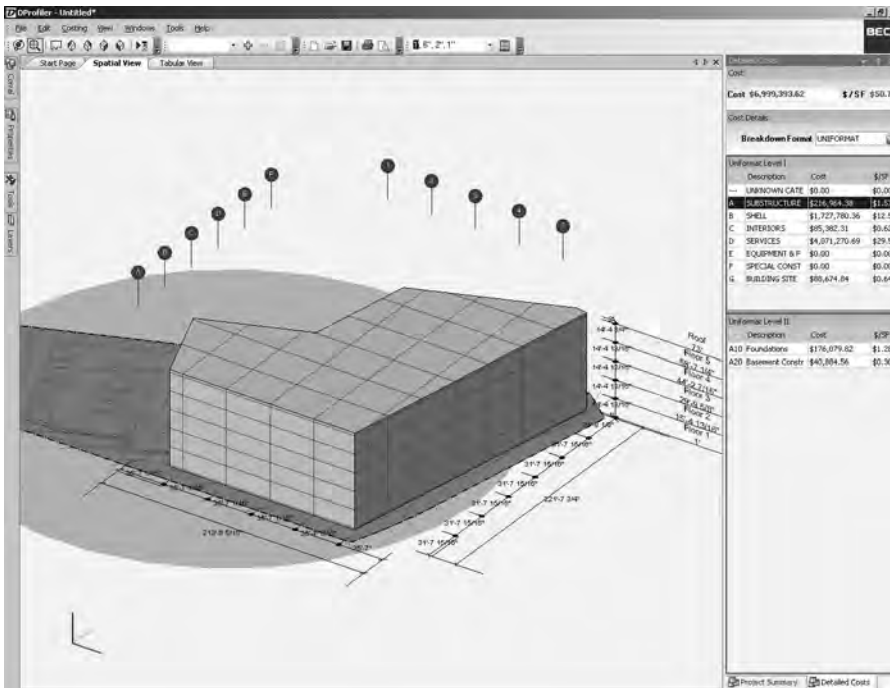
**FIGURE 9-9-4** Snapshot of DProfiler’s detailed cost estimate showing the hierarchy and information.

At the top of the tabular view are 11 model component tabs. Within these tabs, the Collections and Assemblies each contain individual Line Items from the cost database. In the example shown, the Slab component tab is selected and the 5th level (Level Five of the building) is expanded to include the Collections contained in that level. The Elevated Frame Assembly is also selected and expanded to reveal the line item contained within it.

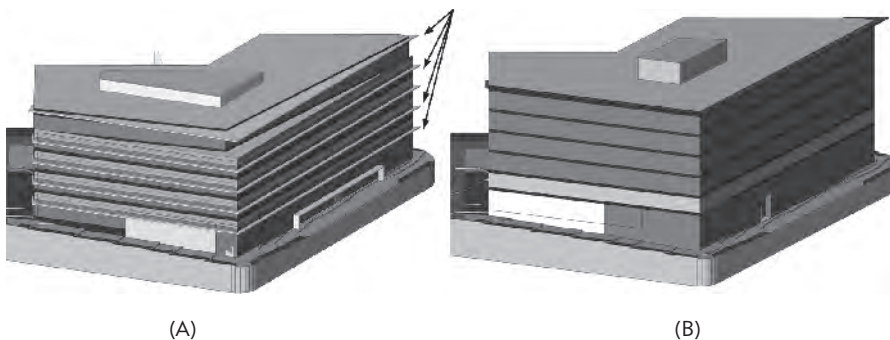
### 9.9.4 Design Alternatives That Were Evaluated

The Beck design-build team also used DProfiler to run several what-if scenarios, once the initial design concept model and its associated estimate were found to be over budget and did not work within the owner’s Proforma framework (see Figure 9-9-5). The team evaluated multiple cost options, such as changing floor-to-floor heights, adding and removing a floor to increase or decrease square footage, relocating the garage component from below to above-grade, and evaluating the current plan against a more rectilinear and potentially more efficient shape to determine the cost premium of the site constraints requiring them to use a less efficient plan and perimeter.

One design option included the use of a glazing frit film on the exterior window wall system, in lieu of constructing costly metal-panel eyebrow overhangs to cope with direct solar exposure from the south and west angles. Figures 9-9-6 (A) and (B) show these two options. The team combined different options (whenever possible) and reviewed this information with the owner.



**FIGURE 9-9-5** Screenshot of the DProfiler system, showing a 2D spatial view of the project, a 3D view, the related Proforma (left corner view), and cost details (along the right side).



**FIGURE 9-9-6** (A) Snapshot of the model, showing a design option with eyebrow canopies for shading the direct sun; (B) Snapshot of the model, showing a design option with canopies removed that uses glazing frit instead.

Glazing frit is a film applied to the interior of the glass and is not visible in the model.

The team was capable of inputting the design variables directly into the owner's financial Proforma (see Figure 9-9-5), such as for leasing square footage, but did not do so on this project. The potential advantage of linking the model directly with the Proforma is that real-time feedback then includes estimated building costs and operating income and expenses. While owners

typically view this information as proprietary, the ability to rapidly evaluate design options based on real building parameters is invaluable. The DProfiler system provides capabilities to link model variables to spreadsheet variables and formulas in Microsoft Excel. In lieu of a direct link to the owner's Proforma, the Beck team used a modified Proforma based on the owner's input in order to evaluate the design options and observe how the increased or decreased square footage impacted the overall results. In response to these features, the owner said:

"By modeling the design options with pricing impacts, we were able to identify the right products for this market. Potential tenants will have high demands, and we have to provide both the right architecture and the right lease rates to satisfy them."

### 9.9.5 Benefits Realized

Conceptual stage cost estimating yields numerous benefits to the owner and the design team. These benefits include:

***Reduction in preconstruction/estimating labor-hours to produce an estimate:*** The reduction in hours came from two sources. First, the typical estimating process requires participation from personnel in the preconstruction team, which includes estimators and experienced construction project managers. With DProfiler, an *experienced* member of the design team can produce an estimate with guidance and input from the project manager, thus reducing their time commitment and overall labor-hours required by the estimating team for the coordination effort. In a traditional setting, the same estimate would require more than one person to perform the same quantity takeoff and estimate in the same timeframe. Second, DProfiler performs the tedious quantity takeoff process, greatly reducing the time required in a traditional approach.

***Accurate cost estimates in real time:*** The parametric model ensures takeoff accuracy by verifying that all items are counted and included, thus reducing the potential for estimating errors. Rapid feedback on cost allows the design team to focus on analyzing the financial impact of design changes, rather than evaluating the accuracy of the estimate.

***Visual representation of the estimate:*** The cost estimate is represented graphically in the 3D model. This reduces potential errors and omissions caused by oversight from the cost estimator. For example, in traditional estimating the exterior wall cladding is quantified by calculating the square footage of the surface area. If an estimator fails to account for the entire

wall area or otherwise omits a section, this area will not be calculated. With DProfiler, if a modeler is missing an area of exterior wall cladding, it becomes apparent in the 3D graphic. In other words, the slab area is a parametric value, meaning that the model calculates its area based on its inherent geometry. The slab is also represented graphically, therefore making it possible to see the slab visually in its geometric form. Because the cost estimate is directly linked to physical components in the model, it is nearly impossible to have a component in the model without an associated cost or vice versa, to have a cost in the estimate not represented by a physical component in the model. For example, the modeler found an area of extra square footage within the building that was not as obvious in the 2D plan and building sections. In response to this, the owner said:

“Using this software offered us the advantage of being able to get the information we needed about the total project cost and simultaneously be able to have visual documentation of what that cost represented.”

### 9.9.6 Conclusion

Conceptual estimating early in the design process yields potentially significant benefits to the owner and design-build team. This case study shows how an organization, over several years, adapted their design process to take advantage of BIM technologies to better serve their clients and produce more cost-effective designs that are better aligned with owner requirements. Achieving these benefits required:

- Experienced designers and project managers who could provide invaluable insight into the digital estimating process. There is a common misperception that these types of new technologies are intelligent solutions and powerful tools that allow younger and less experienced employees to be more productive. This case study demonstrates that use of the tool by skilled and knowledgeable employees with field experience, who understand the assemblies and complexities associated with constructing a building, is immensely valuable. In many cases, these tools require more intelligent input to yield efficiencies and quality in the output.
- Investing time and effort earlier in the process to properly train employees in using the software.
- Customizing the database to fit an organization’s standard estimating processes. As organizations adopt these types of conceptual estimating tools, significant up-front investment is required to translate the estimating

rules and methods to model variables, parameters, and model component properties or attributes. Over time, this up-front investment will decrease substantially for similar types of projects. This may involve developing a standard method to associate building components with cost items using industry formats, such as UniFormat fields, or a custom property that can be easily associated with items in the cost database.

- Cooperation of the owner or client to provide Proforma templates or spreadsheets for evaluating and analyzing the estimated information. Linking these templates to the spreadsheets removes another step in the process and provides the owner with the tools to view the estimate, not just in terms of construction costs but in terms of its impact on operating expenses and income.

## Acknowledgments

---

The authors are indebted to Brent Pilgrim, Stewart Carroll, and Betsy del Monte of the Beck Group for their assistance in providing the information for this case study. Additionally, we would like to thank Ken Reese, Executive Vice President with Hillwood for his comments and support for the case study. All figures used in this case study were provided courtesy of the Beck Group and Hillwood Development.

---

## 9.10 UNITED STATES COAST GUARD BIM IMPLEMENTATION

### *BIM for Scenario Planning and Facility Assessment*

This case study consists of three projects that highlight the use of BIM for scenario planning at a project and enterprise level and for facility asset management. The projects demonstrate the United States Coast Guard's effort to implement BIM to support tactical and strategic business missions using Web-based services and open standards enabled by BIM and accessible to a wide range of users.

### 9.10.0 Introduction

The United States Coast Guard (USCG) plans, designs, builds, and manages a portfolio of 8,000 owned or leased buildings and nationwide land holdings. For any given project, the USCG may be the owner, tenant, or design team. These multiple perspectives give them many potential opportunities to apply BIM and reengineer the processes of their Civil Engineering Division.

In 2001, the USCG determined that BIM was a foundation technology for their Shore Facility Capital Asset Management (SFCAM) Roadmap. This decision was enabled by the Logistic Geospatial Information Center (LoGIC) under the direction of Paul Herold. David Hammond led the USCG SFCAM Roadmap effort, and members of the team included AECinfosystems, Inc.; Onuma, Inc.; MACTEC; Standing Stone Consulting; and Tradewinds, a change management group.

The Roadmap (see Figure 9–10–1) is an enterprise focused on converging data and knowledge across multiple sectors—the various functional units within the USCG—to facilitate better decision-making for strategic asset planning and missions. Integral to this vision is the notion that process changes that support the capture of data and knowledge throughout a project lifecycle and across projects will produce a more efficient and sustainable facility delivery and management process workflow. For the USCG, the lifecycle of a business decision spans a very wide range, from very early planning, design, and construction to facility management and disposal. Additionally, the Roadmap identifies the need to manage information about an organization including its

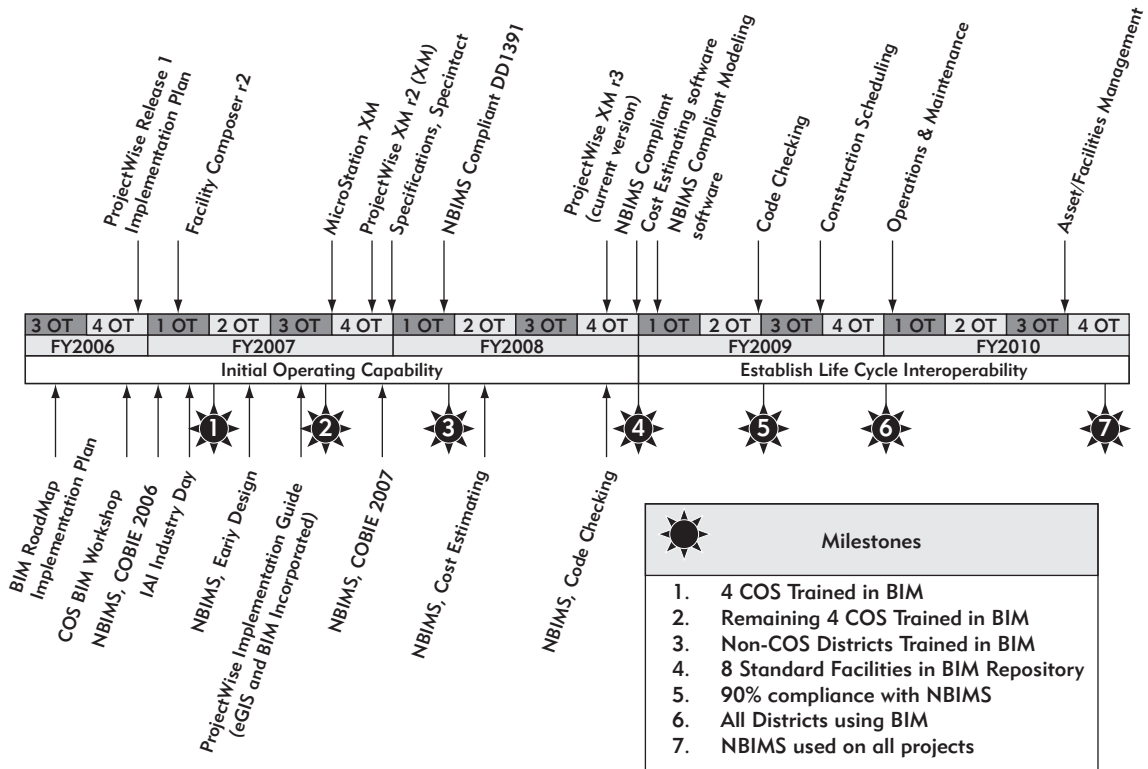


FIGURE 9–10–1 The United States Coast Guard’s Roadmap for implementing BIM and their interoperability goals.

functions and operations, which are often more valuable than the physical assets. Consequently, any effort to implement BIM or related technologies must support the integration of a wide variety of data and decision-making processes very early during planning and align those decisions with key business drivers.

Figure 9–10–1 shows an example of the USCG Roadmap and the various milestones they have established with respect to the implementation of BIM. The following sections describe three projects that use BIM in the context of this Roadmap, for early design and facility operations and management. In these projects, BIM is the central enabling technology. Other technologies such as Web portals, GIS, and databases were integrated with BIM to fulfill specific project requirements and meet the goals established by the USCG. The projects also highlight the process changes that were necessary to successfully implement BIM and achieve an integrated process and data model.

Table 9–10–1 provides an overview of the participants and goals of the three projects.

**Table 9–10–1** Overview of the USCG Projects and Its Partner Service Providers

<b>Project Name</b>	<b>Integrated Support Command (ISC) Alameda project</b>	<b>Sector Command Centers</b>	<b>Off-Cycle Crew Support Units (OCCSU)</b>
<b>Location:</b>	Alameda site	35 sites	9 sites
<b>Project Description:</b>	Consolidate and integrate facility assessment information into a single data repository	Perform conceptual design of 35 sector command facilities and define requirements for those facilities	Perform multiple what-if scenarios for future projects related to installations of new boats, including operational, staffing, cost, and security analysis
<b>Project Duration:</b>	3 months  Model of Alameda Island was created earlier by AEC info systems, Inc., Onuma, Inc.	6 months	5 months
<b>BIM Application:</b>	Facility assessment and asset management	Conceptual planning and requirement definition	Rapid conceptual planning and analysis
<b>Key Participants:</b>		USCG Headquarters–SFCAM Logistics Geospatial Integration Center USCG Headquarters, Civil Engineering CEU Oakland FD & CC Pacific Onuma, Inc. AECinfosystems, Inc. NexDSS, MACTEC Standing Stone Consulting, Inc.	



### 9.10.1 BIM for Facility Assessment and Planning

The USCG continually assesses the condition of existing facilities, their mission dependency, and current space utilization. These metrics are used to analyze enterprise planning, including whether to renovate or maintain existing facilities or build new ones. In the traditional process, a team would collect and create floor plans of existing facilities and repeat this effort every few years. The analysis effort would occur in parallel with separate documents that typically are not directly associated or linked to the floor plan or facility documentation. For the USCG, this type of task was ripe for leveraging intelligent objects in BIM applications to optimize data entry, knowledge capture, and data reporting, as shown in their facility assessment Roadmap in Figure 9–10–2. This Roadmap communicates the ideal assessment workflow using BIM to capture and store assessment information.

#### *Requirements for a Facility Assessment System*

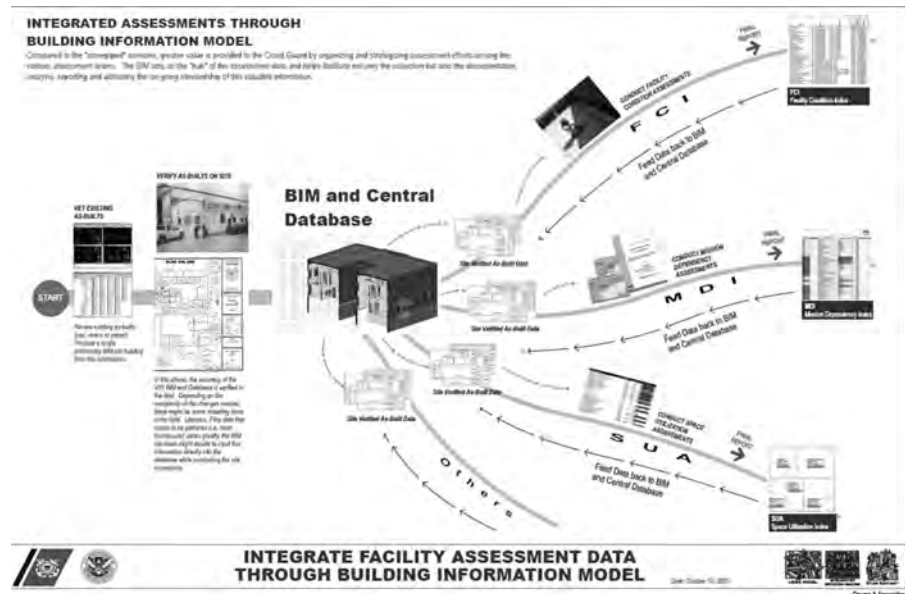
A critical requirement for implementing a BIM-enabled assessment process is to ensure that the facility objects are modeled once—either during the design and construction process or post-construction—and assessment teams can associate those components with the following types of assessment information:

- **Facility Condition Index** represents the condition of various parts of the building, roof, walls, windows, and equipment. Each building component or aggregate of components, for instance, a building system, is associated with a numerical index typically assigned based on field surveys and ranging from 0 (failure) to 100 (all of its design life remaining).
- **Mission Dependency Index** represents parts of the facilities that are critical to business or mission operations, with a value of 100 representing a system with highest priority and 0 with lowest priority relative to a mission.
- **Space Utilization Index** represents the compliance of the actual space to USCG standards. A 1.0 value indicates a space complying exactly with USCG space standards, and values between .95 (slightly less than allowable) and 1.15 (slightly greater than allowable) are reasonable.

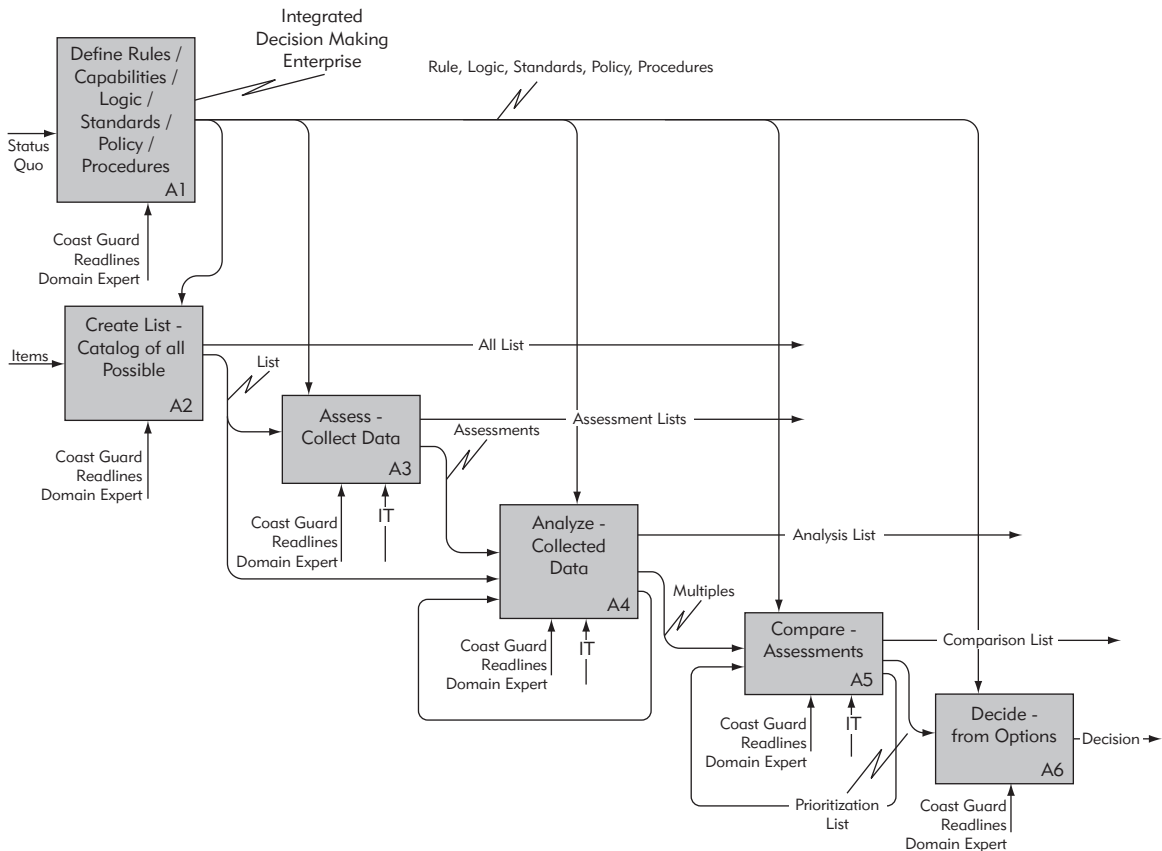
Although data will change over time—based on physical and operational changes—the system should support ongoing manual updates, and automatic updates. Some of the assessment data can be more readily updated or calculated using intelligent rules or associations with other enterprise data systems. Furthermore, the staff equipped with the knowledge and expertise to update

**FIGURE 9-10-2**

(A) Roadmap for facility assessment showing the ideal information and process workflow to support facility assessment based on a building information model database.



(B) Assessment process as outlined in the Roadmap.



this data is not typically trained to use 2D or 3D CAD systems. The system must allow such staff to enter the data without extensive training. Finally, the system needs to support reporting capabilities for communicating information and analyses to a broad constituency, ranging from design professionals to laypeople.

### ***Description of the Facility Assessment System***

The USCG contracted Onuma, Inc. and AECInfosystems, Inc. to develop and implement a BIM-based assessment system. These service providers were proficient with a variety of BIM tools as well as other enabling technologies, such as databases and Web-based tools. Additionally, Onuma and AECInfosystems had the expertise to model the facilities and to work with and train the USCG staff for widespread implementation. Both companies were familiar with the USCG organization and were involved in the Roadmap efforts. One challenge for the service providers was working within the task-centric or project-oriented deliverables mandated by USCG contracts.

Consequently, the development of various assessment tools and implementation and training of new assessment work processes spanned several projects. The service providers understood that integrating these disparate processes was a central goal governing the project's success and successfully developed and customized an assessment system over several projects and contracts.

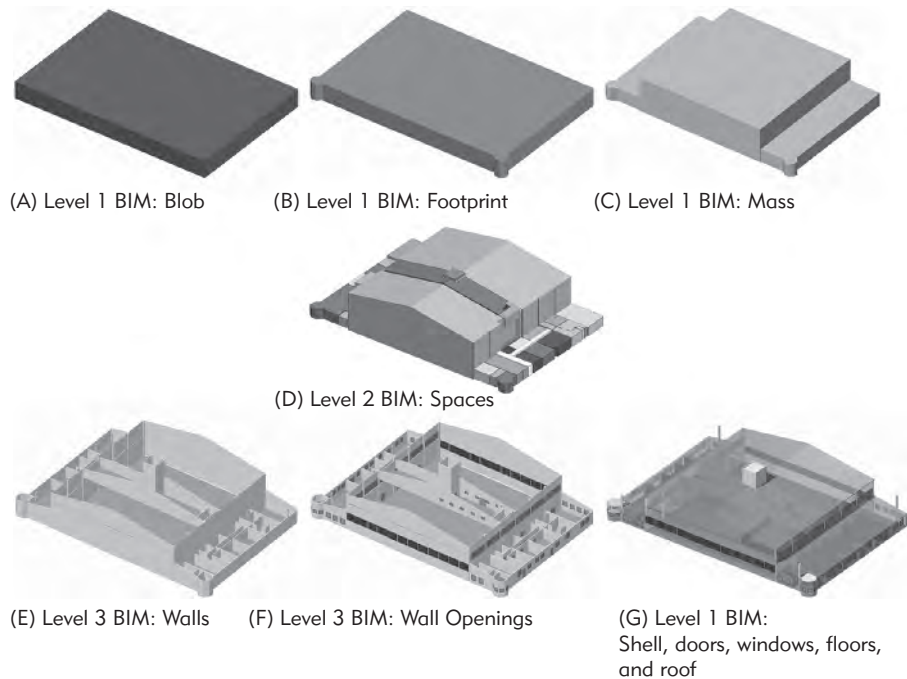
Off-the-shelf BIM tools have built-in features to define custom objects and properties (see Chapter 2); but they lack the ability to integrate objects within enterprise systems such as central databases, and they cannot access component information via the Web. To address these shortcomings, Onuma customized the ONUMA Planning System™ (OPS), a Web-enabled application that links BIM design tools with a central database built on open source environments (MySQL™ and Apache™). This system has been renamed the Oonuma System in 2010 (see <http://onuma.com/products/OnumaPlanningSystem.php>). We will use its original name, OPS, throughout this case study.

For the assessment project, the critical components of OPS were the links between the BIM design tool (ArchiCAD®), a central model repository, and the Web portal for entering and viewing assessment data. The system is based on open standards including IFCs and XML to support interoperability and integration; and it includes interfaces to applications that are vital to the information or process workflows, such as Microsoft® Excel for data entry and reporting and Google™ Earth for earth-based visualizations.

The data for facility information on the ISC project came from multiple teams and sources, including: (1) existing 2D drawings, (2) existing ArchiCAD building models, (3) assessment data from multiple assessment teams, (4) data

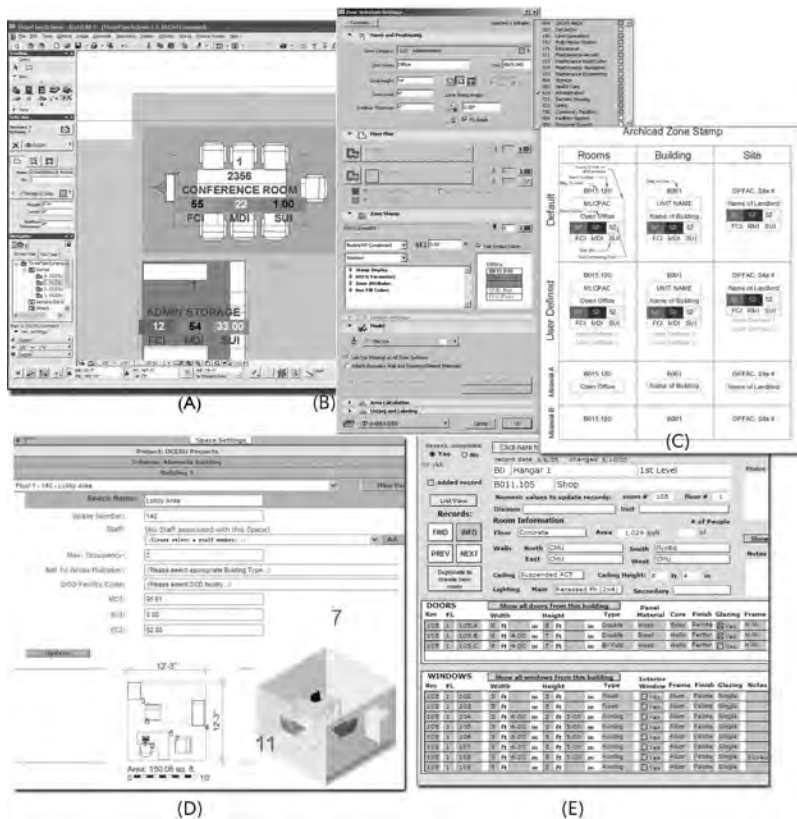
**FIGURE 9-10-3**

Shows the different levels of detail in a building information model.



from field assessors, and (5) new data created in ArchiCAD. Most critical was the as-built data. As-built room (zone objects in ArchiCAD and space objects in OPS) and building objects established the project information work breakdown structure and standards. Each of these objects was assigned a unique identifier (ID); and when combined with the building ID, this creates a unique identifier reference. Any data associated with the project must be associated with one of these core building objects via the ID.

After a team creates a Level 2 or Level 3 building model (see Figure 9-10-3), the team exports it to a database which acts as the central data repository and model server. The database is populated with various building objects, each with its own unique identifier and associated object parameters (such as variable dimensions) and properties (such as the assessment index values shown in Figure 9-10-4). Once the building data is in the database, teams can access the model data via a Web interface and edit or update the object parameters and properties, also shown in Figure 9-10-4. Many of the properties require that the user select from a predefined list of values to ensure validity and to mitigate potential data entry errors. For smaller projects, manual data entry is feasible. For example, a user can open a space setting, use pull-down menus to see how the space is utilized, and manually select its mission readiness index.

**FIGURE 9-10-4**

Interfaces to input room information in OPS.

(A) View of room (zone) in BIM authoring tool with data from OPS; (B) A custom zone-object interface in the ArchiCAD® environment; (C) User-defined room stamps to display data from OPS in ArchiCAD; (D) Room (space) visual user interface in Web-based OPS environment; and (E) room data view in OPS.

The user can repeat this process for doors, windows, walls, and assessment objects. In many cases, a user must adjust multiple properties for each object.

On large projects, entering data in a Microsoft Excel spreadsheet can greatly expedite data entry and the updating processes. The teams can import data from the Microsoft Excel file into the OPS database only if the building object contains a valid room ID and object property values. The OPS workflow requires that teams conform to the standards, and it enforces consistency. Any view of the building assessment data links to this database. Thus, if a team opens the building model in ArchiCAD after additional assessment data updates, the updates are available within the ArchiCAD environment.

Different methodologies for entering data in the OPS system support scalability and flexibility. An average building requires that teams enter 10,000 data points or object property values, and each of these data points requires ongoing management. For a site encompassing ten facilities, the complexity of managing the assessment workflow process and managing the data dramatically increases. Thus, OPS provides multiple ways for teams to enter data,

manually or automatically, via the Web, spreadsheets, or BIM environments; and OPS manages the data in a central BIM-based model server.

### ***Use of the Planning System on the ISC Project***

The USCG is faced with documenting and assessing over 33 million square feet of facilities. To test its Roadmap goals, the team (see Table 9–10–1 for a list of team members) implemented the assessment system for the Integrated Support Command (ISC Alameda), located on Coast Guard Island in Alameda, California. The ISC site contains 35 facilities totaling 700,000 different objects. This medium-scale implementation of OPS involved:

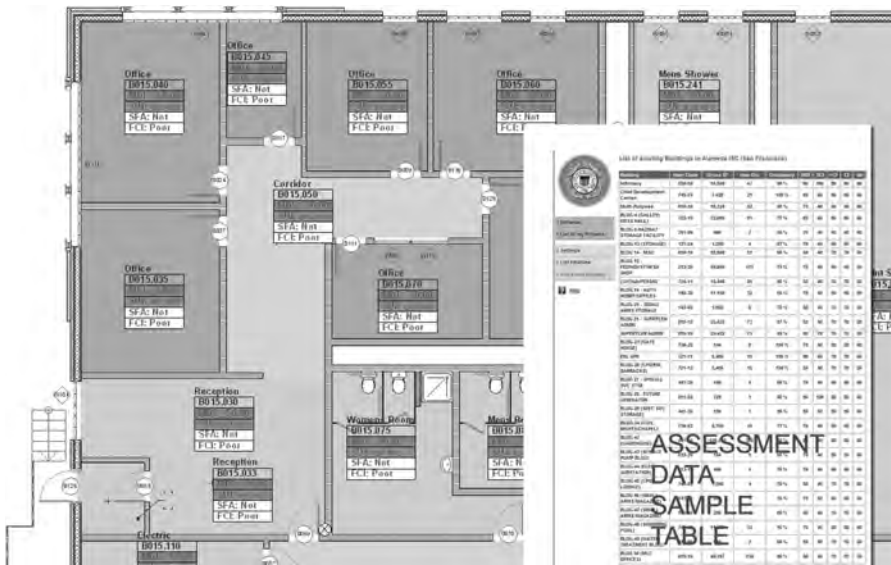
- Documenting 35 facilities at the Level 3 BIM detail, consisting of spaces, walls, doors, and windows
- Attaching assessment data and metrics to facility objects
- Managing updates to the assessment data

The as-built documentation consisted primarily of paper drawings or 2D CAD files. The as-built data was created in ArchiCAD using a combination of custom room and building objects, custom USCG objects, and built-in ArchiCAD objects. These included:

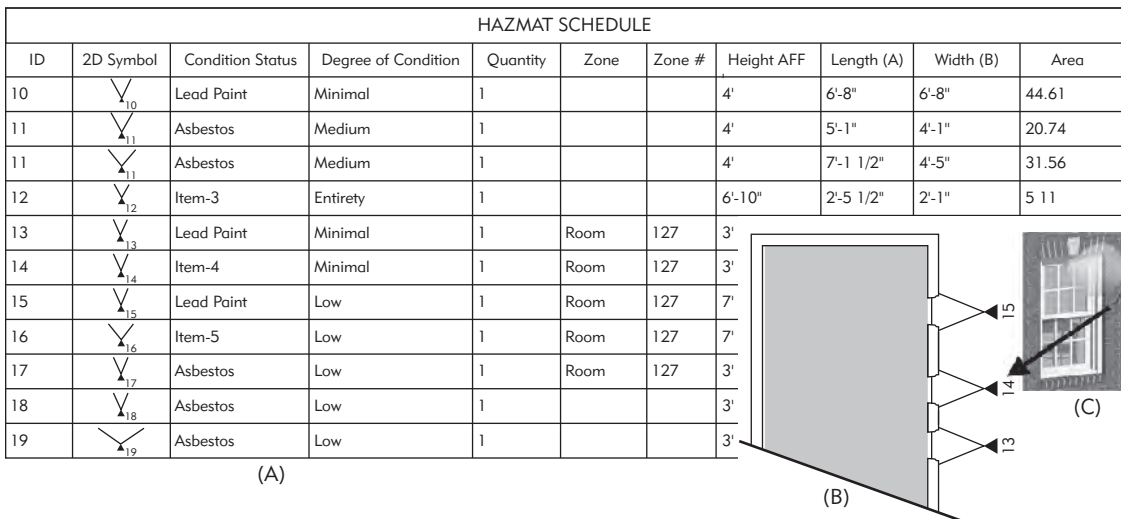
- Site plan with features
- Buildings
- Interior walls
- Doors and windows
- Furniture and equipment
- Assessment data associated with each object

Figure 9–10–5A shows a sample building model and the level of detail for that model. Figure 9–10–5B shows a Web-based data view of a room object with a list of associated doors, windows, and parameters and properties for all objects as well as the room's assessment status.

The assessment information came from multiple teams, many not trained to use ArchiCAD. The OPS' Web interface provided a simple way to enter assessment data while situated in the office or field. For example, capturing knowledge about hazardous materials is critical to each assessment. The team in the field records the types of hazards (lead paint, asbestos, and the like), the condition, its quantity, location, height above the finish floor, and other data points directly in the model. They can create a new hazard object, add it to



**FIGURE 9-10-5** (A) Plan view showing assessment values assigned to each room and (B) an integrated assessment data table combining data from multiple facilities.



**FIGURE 9-10-6** (A) Schedule to view hazardous material data from all hazardous material objects in a building. (B) Plan view showing the hazardous object symbols. (C) 3D views of the hazardous material object.

the model, and enter object parameters via pull-down menus for quick capture with the added benefit of data consistency across team members.

Upon return to the office, the team can generate a report in schedule form that summarizes information captured in the field or related to a specific room (see Figure 9-10-6).

**Table 9–10–2** Comparison of the Manual and BIM-Based Assessment Processes for the USCG, Based on Alameda Project Data

	Manual BIM	Database and BIM-Based
Typical Building Size (SF):	20,000	20,000
Data Points per Bldg:	10,000	10,000
Data Points per SF:	.5	.5
USCG Total SF:	33,000,000	33,000,000
USCG Data Points:	16,500,000	16,500,000
Time to Edit One Data Point (sec):	2	.04 (2% of manual time)
Total Time in Hours:	9,166	183
4 Iterations per Project:	36,666	733

One of the teams used specialized software called Vertex® (an engineering management system) to calculate the condition index based on the density and severity of observable defects (Mactec 2007). Using Microsoft Excel's import tool, the teams were able to automatically populate building objects with condition index values exported from Vertex.

By employing these methods to enter asset data and combining the information into an integrated model, the team reduced the updating effort by 98 percent compared to the traditional manual-based data entry and updating of assessment information. Table 9–10–2 shows a comparison between the manual method of updating information and the BIM-based method, either at the creation of asset information, post-construction, or during regular assessment updates. The time required to edit a single data point is reduced from 2 to .04 seconds. This amount represents time savings derived from several sources, including automatic updates from Vertex, Microsoft Excel data, and the reduction in manual errors. The overall time savings is significant when spread across four projects.

### ***Lessons Learned from Small-Scale Implementation of a BIM-Based Assessment System***

A BIM tool alone is insufficient to support enterprise-level demands for knowledge capture and sharing, but it is integral to the process. OPS allowed the USCG to integrate building information model data with enterprise data from other analysis tools, such as Vertex in a usable and integrative manner that supports critical work processes, reduces the effort required to update data, and improves quality and accuracy.



### 9.10.2 BIM for Scenario Planning

The USCG must rapidly adopt and respond to ever-changing missions. In response to the September 11, 2001, terrorist attacks, under budgetary constraints and with altered mission objectives, the USCG established requirements for integrating the Group Commander and port operations into a single Sector Command Center. This presented a unique challenge. Not only did they need to define a new facility type and develop official standards for it, but they had to rapidly plan 35 of these centers in strategic locations as quickly as possible.

#### *Requirements for BIM-Based Scenario Planning System*

The USCG needed a system that provided the structure and template for a Sector Command Center that would enable teams to rapidly design them while conforming to specified space standards. At the start of the project, however, these standards did not exist, or were incomplete; nor were there the templates for defining them. Thus, the system needed to include functionality for consistently defining space standards and features for application to new facility designs.

#### *Description of the Scenario Planning System*

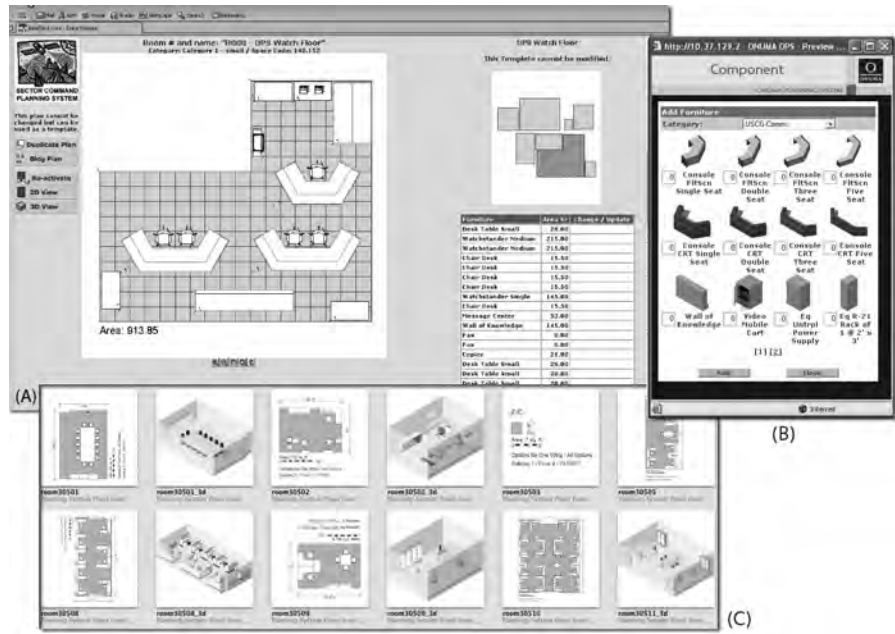
The USCG contracted Onuma, Inc. and AECinfosystems, Inc. to develop and implement a scenario-based planning system using OPS. The goal was to create a system that supported scenario planning without any training or understanding of BIM, yet the system had to be integrated with a building model. The way this was accomplished was by using a Web-based interface that worked with BIM through OPS.

Figures 9–10–7, 9–10–8, and 9–10–9 show various parts of the Sector Command Center planning tool:

- 1. Project management:** Figure 9–10–8A is a Web portal to access current projects and scenarios (schemes) and to create new projects. A specific Sector Command Center, for example, might have three or four schemes or design options. Users can import the functional requirements. Functional requirements are data-rich space and/or room models that support additional information to allow rapid decision processes and extraction of data. Additional information may include metric data such as Mission Dependency Index, space use requirements, equipment, level of security, costing, adjacencies, and so forth.
- 2. Building planner:** Figure 9–10–8 A and B provides the user with a high-level layout of a single floor of a Sector Command Center consisting of room objects based on room templates. A command center could be a standalone facility or part of an existing or new facility.

**FIGURE 9-10-7**

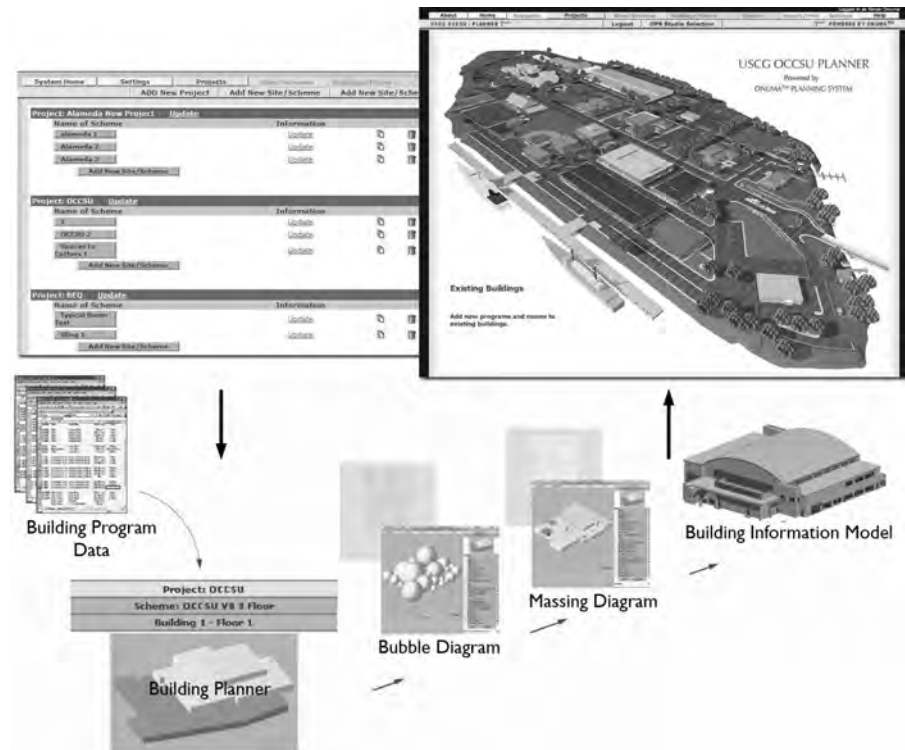
(A) A sample room showing a template layout and a list of furniture for the room; (B) a USCG furniture library; and (C) samples of room templates in 2D and 3D views.

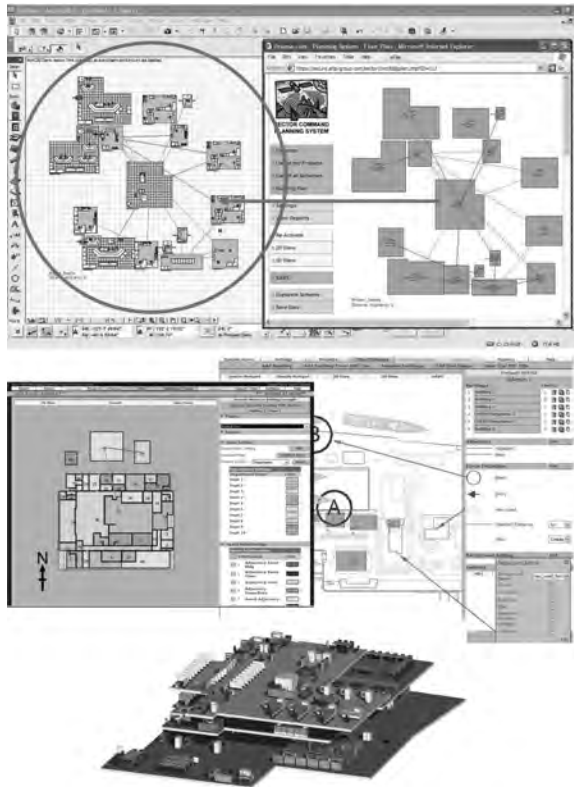


**FIGURE 9-10-8**

The workflow of the OCCSU Planner system.

(A) the project management portal to create schemes; (B) the building planner to design a scheme using building program data; (C) refinement of the scheme from masses, relationships between spaces in a bubble diagram, to more detailed massing, and then to a building information model; and (D) publishing of the model and viewing the scheme in the project site.



**FIGURE 9-10-9**

Views of building model data created and developed in the OCCSU Planner system.

2D layout views in (A) ArchiCAD and (B) Web-based OPS system. Views of the intelligent relationships between spaces and other objects such as (C) *adjacency* and *avoid* relationships between spaces; and (D) a 2D bomb blast object for security analysis. (E) View of the building model detail produced from the scenario planning system including floors and furniture.

3. **2D room layout:** Figure 9-10-7A is a detailed view of a room or room template with the ability to modify and edit the layout if the user has edit privileges. The room view also includes a list of the associated furniture and room properties and parameters.
4. **3D room layout:** Figure 9-10-7C shows a 3D view of a room for visualization purposes.
5. **Export utilities** include exporters to ArchiCAD, AutoCAD, or in IFC format.
6. **Reporting tools** provide the user with multiple ways to view a scenario and related analyses (similar to those in Figures 9-10-4 A through E).

### ***Implementation of the Scenario Planning System***

OPS provided the USCG with a tool for generating and comparing Sector Command Center designs. Through charrettes, the teams used the system to design and evaluate Sector Command Centers in various locations. At the start of the project, the team had a set of initial room templates and programmatic requirements based on previous projects. Throughout the process, these template designs

**Table 9–10–3** Metrics for Implementing BIM-Based Scenario Planning for the Design of Sector Command Centers

	<b>Traditional Design</b>	<b>BIM-Based Design with OPS</b>
Number of Projects:	35	35
Average Size of Each:	5,000 sf	5,000 sf
Average Time to Complete Design for One Project Using Traditional Processes	10 Months	1 Month
Total Time to Complete 35 Projects Using Traditional Processes	350 Months	6 Months, 1.7% of traditional design
Estimated Time Savings for Design Only		344 Months

evolved and the requirements changed. The management features of OPS allowed them to build template rooms and record new requirements. As a new Sector Command Center was designed, they often discovered missing template rooms and other necessary requirement changes. This self-documenting process was a direct byproduct of the use of a data-rich and visually interactive environment.

Over a period of six months, the team successfully generated conceptual designs and related requirements for 35 Sector Command facilities. Traditionally, each project would take 10 months as documented in Table 9–10–3. With OPS, the conceptual design process was reduced to one month. With OPS, the team could analyze each design in terms of functional requirements, cost, and conformance with USCG standards. Similar to the ICS project, the use of templates forced consistency. When the teams discovered a need for a new room template or modification to an existing one, the system automatically captured these requirements.

At the conclusion of concept design for each facility, the team produced programmatic requirements for the Sector Command facility, 2D and 3D conceptual layouts, and reports documenting the equipment and furniture lists. This detail at the conceptual stage provided the USCG with much richer information to bid and procure a facility in less time.

### ***Lessons Learned from the Implementation of a BIM-Based Scenario Planning System***

The parametric template-based approach to scenario planning dramatically reduced the overall time required to design each Sector Command Center. It allowed the USCG to continually build new prototype requirements and develop standards, even as they were designing and as new mission requirements evolved. OPS provided the benefits of building information modeling via an easy-to-use interface for early conceptual design, and it provided the teams

## Quotes from USCG Personnel Discussing Benefits of SCCP:

“The main benefit from using a system like this goes beyond the actual process of designing and coming to consensus with a large group of stakeholders. The process of using an integrated system like this in itself creates an engine that supplies answers and collects knowledge that can be used in many different ways beyond the immediate need to define the requirements for a project.”

“The Sector Command Center Planning Tool was the genesis of the Web-enabled, rapid planning, 3-D system. Planners all over the Coast Guard used this tool to generate 35 detailed reports in a matter of six months with little to no training on the intuitive SCC Tool. We have found that this has categorically improved communication in the early planning stages between our engineers, architects and our customers.”

V.K. Holtzman-Bell, Captain U.S. Coast Guard.

with rapid feedback and real-time analysis of conceptual designs in visual and interactive formats. The rapid analysis capability allowed decisions to be made faster and eliminate options that would not support the needs of the client.

### 9.10.3 OCCSU System

The previous two projects focused on facility asset management and conceptual design. The OCCSU project addresses the feasibility phase of a project when an owner like the U.S. Coast Guard must make critical and costly decisions to define a project and align the business drivers (demand) with available facilities. The business drivers for the OCCSU project are new cutters (ships) that will be completed over the next 10 to 12 years. These boats represent a new business model and a new project type for the USCG. The delivery date and location is unknown, but the USCG must plan for their deployment and be ready to procure the work for design and construction as delivery dates and locations are finalized.

#### ***Requirements for the OCCSU System***

All variables in the OCCSU project are dynamic including timing, function, organization, and location. Each new boat might require 100 people on standby support and crew rotation. Scenarios, such as how to rotate crews and support the boats, would have a direct impact on what facilities would be needed. This would entail facilities for housing standby support and crews and the maintenance of shore-side facilities and command centers. Thus, scenario planning would entail visualization of the entire site, multiple facilities, and individual buildings across multiple floors.

The template-based approach to designing the Sector Command Centers was the starting point for the OCCSU project; and the assessment models developed for the ICS project provided some of the as-built information. Two critical pieces were required to support the what-if scenarios: (1) links to a geospatial database or GIS system, where most existing information resided and (2) richer analysis tools to support analysis of the scenarios. The most important types of analyses were related to security.

### ***Implementation of the OCCSU System***

There were about 10 sites that the USCG chose to evaluate for the OCCSU project. Some sites were part of their previous efforts to produce as-built models of their facilities, such as for the ICS project. These facilities were already in OPS and existed in ArchiCAD. Other sites only had 2D site building drawings and some buildings had no information at all. For example, Figure 9–10–9 shows a 3D view of one of the project sites consisting of various levels of details for each facility. This model also serves as an interface to a project and its various scenarios (schemes).

Each project can have multiple schemes, and each scheme represents a specific project location and associated requirements. The workflow is similar to that described for the Sector Command Center planning system. The team starts with a template or defines a new one. They view the space in 2D or 3D and define and create one or multiple floors. The addition of new furniture or equipment is only from a USCG-approved furniture database.

Each space can have *adjacency* or *avoid* relationships with other spaces, and the team can view these in the 2D layout view, as shown in Figure 9–10–9. As a scenario is created, the team can view reports that show cost (based on square footage historical data) or building capacity. (A LEED analysis checklist was added to OPS after OCCSU.) At any time they can export the scenario to IFC or ArchiCAD (via XML) to view the facility in 3D and add walls, doors, and windows. For security analyses, they can add a *blast object* from a database, which represents different types and sizes of blasts (shown in Figure 9–10–9B).

### ***Lessons Learned***

The OCCSU planning system demonstrates how owners can use BIM to support enterprise scenario planning to define and evaluate projects before they are financed or funded. OPS provides the USCG planning teams with an integrated and shared operational picture of various scenarios to support real-time decision-making. The decision-making shifts to a much earlier part of the design process and allows the USCG planning teams to predict the potential outcomes of various what-if scenarios. This type of scenario-based planning is different from today's reactive, linear, and time-consuming approach to facility

## Quotes Summarizing Benefits of OCCSU

“The Onuma Planning System shifted the reality of true scenario-based planning to an enterprise level, enabling us to link shore facilities and infrastructure to mission execution and strategic Coast Guard-wide outcomes. This better enabled us to allocate infrastructure resources to the most important mission execution and outcomes.

The integration of BIM, geospatial data, real property data and mission requirements supports the need of a common operational picture for the USCG. This common operational picture can be real-time tactical information as well as longer-term strategic information, which is enabled by the Onuma Planning System.”

David Hammond, Chief, SFCAM Division Commandant, (CG-434) U.S. Coast Guard.

design and construction. These process changes yield significant benefits, yet require significant cultural and contractual changes.

Today’s contractual methods are designed to support the single project approach. To extend the success of the OCCSU Planning System enterprise-wide within the Coast Guard, the contracts and relationships with consultants will need to change and evolve to support multiple projects, nonlinear processes, and integrative approaches. Today, BIM is commonly used as a tool for architects to design a project and create construction drawings within a well-defined deliverable-based process. When BIM is integrated with metric data and supported at an enterprise level, it becomes a visual decision tool for strategic planning. It also feeds the architectural design tasks with useful and more complete information from the client. Issues related to contracting services to add this metric data, often from multiple services and across projects, still exist and need to be addressed.

For the U.S. Coast Guard, and other owners, the investment in the site and building data can pay off tremendously if the data is integrated, consistent, and accessible. That is, the USCG needs to ensure that any service provider can have access to the data, such as templates, and leverage enterprise data. Since the OCCSU system forces normalization, all service providers should benefit from access to as-built data and integration of site and other operational data.

### 9.10.4 Conclusions and Lessons Learned

These projects demonstrate the dramatic cost and time savings associated with BIM-based planning and facility asset management. Much of the savings are attributed to standardizing work processes and capturing knowledge digitally,

rather than through labor-intensive manual processes. In implementing these BIM-based systems, the key lessons learned were:

- BIM-based work processes require significant cultural changes. These range from simple work process changes related to digital data entry to working with templates instead of freeform design. To prepare and plan for the impact of these changes, the USCG understood that wide-scale implementation would require realistic roadmaps, and they opted to perform small-scale implementations, such as the ISC project, before implementing large-scale efforts, such as the OCCSU project.
- It is imperative to make BIM accessible to a wide range of users. Broad access to the model for viewing and editing as well as creating scenarios was paramount to the success of OPS on these projects.
- Parametric object-based tools provide the building blocks for capturing knowledge and project requirements that inevitably change over time.
- BIM promotes standards and work processes designed on BIM-based OPS, which forced data normalization, reduced errors, and increased the value and quality of as-built information.

The value of the information from multiple projects such as the ISC project, Sector Command Center Planning System, and OCCSU Planning System exponentially increases as more integration happens. Unexpected connections between data in these projects, such as the value of the as-built assessment data in the ISC to the what-if scenario planning in OCCSU demonstrate a return on the investment in an integrated, consistent, and standard enterprise building model.

## Acknowledgments

The authors are indebted to Kimon Onuma of Onuma, Inc. and Dianne Davis of AECinfosystems, Inc. for their assistance in providing the information contained in this case study. Additional participants who were instrumental include: from USCG Headquarters Captain Jay Manik and David Hammond, Lieutenant Commander Robert Bevins, (SFCAM) Lieutenant Commander Scott Gesele, and William Logan, and Hassan Zaidi (Civil Engineering), Commander James Dempsey from CEU Oakland; and from FD&CC Pacific Captain Virginia Holtzmanbell, William Scherer, and Jeffrey Brockus; Paul Herold and team from the Logistics Geospatial Integration Center; Jim Watson and team from NexDSS (Mactec); Ian Thompson and team from Standing Stone Consulting, Inc. All figures were provided courtesy of Onuma, Inc. and AECinfosystems, Inc.



# Glossary

---

## **B-rep (Boundary representation)**

3D geometry of a solid shape as defined by its bounding surfaces. Used by most 3D CAD tools for display, clash detection and measurement to points on surfaces.

## **BIM application**

A very broad category of any software that can be used with a BIM platform or BIM environment to support Building Information Modeling. Thus traditional applications such as drafting, rendering, specification writing and engineering analysis tools are all potentially BIM applications, if workflows and/or data exchange integrates them in Building Information Modeling.

The term can be further qualified to denote specific application areas. For example, “BIM Architectural Design Application” is often used to refer to applications used primarily for architectural design, such as Revit®Architecture, Bentley Architecture, DigitalProject® and ArchiCAD®, or “BIM 4D application,” that supports animation of a BIM model according to an associated construction schedule.

## **BIM platform**

A BIM design application that generates data for multiple uses and incorporates multiple tools directly or through interfaces with varying levels of integration. Most BIM design applications serve not only a tool function, such as 3D parametric object modeling, but also other functions, such as drawing production and application interface, making them also platforms.

## **BIM environment**

A BIM environment is the functional capability embedded in a BIM Server. It encompasses the data management information, and software for enforcing policies and practices that integrate the applications (tools or platforms) within an organization. Often the BIM environment is not conceptualized explicitly, but grows in ad hoc manner, driven by needs within the firm. Integration and support across multiple BIM platforms is its critical *raison d'être*, as well as managing communication with external systems. A BIM environment is supported by a set of policies and practices that facilitates management of BIM project data.

**BIM process**

A process that relies on the information generated by a BIM design tool for analysis, fabrication detailing, cost estimation, scheduling or other use.

**BIM server**

A BIM server is a database system whose schema is based on an object based format. It is different from existing project data management (PDM) systems and web-based project management systems in that PDM systems are file based systems, and carry CAD and analysis package project files. BIM servers are object-based, allowing query, transfer, updating and management of individual project objects from a potentially heterogeneous set of applications. BIM servers are targeted to support BIM environments.

**BIM system**

A software system that incorporates a BIM design application and other applications that utilize the BIM data. The system may be connected through a local area network or the Internet.

**BIM tool**

A task-specific software application that manipulates a building model for some defined purpose and produces a specific outcome. Examples of tools include those used for drawing production, specification writing, cost estimation, clash and error detection, energy analysis, rendering and visualization.

**Boolean operations**

The class of operations allowing editing of shapes by merging two shapes together, subtracting one shape from another, or defining the intersection of two or more shapes. This approach is named after George Boole, who invented the union, intersection, and difference operations on mathematical sets.

**Building Data Model**

An object schema suitable for representing a building and its supporting data, such as information about building parts, users, energy loads, or processes. A building data model may be used to represent schemas for file exchange, for XML-based web exchange, or to define a database schema for a repository. The main examples of building data models are IFC and CIS/2.

**Building Information Modeling (BIM)**

We use BIM as a verb or an adjective phrase to describe tools, processes and technologies that are facilitated by digital, machine—readable documentation about a building, its performance, its planning, its construction and later its operation. Therefore BIM describes an activity, not an object. To describe the result of the modeling activity, we use the term “building information model,” or more simply “building model” in full.

**Building Model (or Building Object Model)**

This consists of a digital database of a particular building that contains information about its objects. This may include its geometry (generally defined by parametric rules), its performance, its planning, its construction and later its operation. A Revit® model and a Digital Project® model of a building are examples of building models. “Building model” can be considered the next-generation replacement for “construction drawings,” or “architectural drawings.” Downstream in the process, the term “fabrication model” is already in common use as a replacement for “shop drawings.”

**Building model repository**

See BIM Server.

A building model repository is a database system whose schema is based on a building object based format. It is different from existing project data management (PDM) systems and web-based project management systems in that the PDM systems are file based, and carry CAD and analysis package project files. Building model repositories are object-based, allowing query, transfer, updating and management of individual project objects from a potentially heterogeneous set of applications.

**Building objects**

Building objects are the things or parts that make up a building. Objects can be aggregated into higher level objects, such as “Assemblies”; assemblies are also objects. More generally, an object is any unit of a building that has properties associated with it. Thus the spaces in a building are also objects. Building objects are a subset of the objects making up a building model. In parts of the text, *element* or *component* is used as a synonym for object.

**CIS/2(CIMsteel Integration Standard/version 2)**

A data exchange schema specifically addressed to represent steel in buildings and structures. This standard is endorsed and supported by the American Institute of Steel Construction. It relies on ISO-STEP software technology.

**CSG (Constructive Solid Geometry)**

A method of solid modeling that builds up complex shapes by combining simple shapes using the Boolean operations. It stores shapes by the tree of operations used to construct the shape. This is a core capability of parametric modeling.

**Exchange format**

A format for laying out data that can be used to exchange information. Example exchange formats are IGES and DXF.

**Exchange Schema**

A method to define the structure of data for exchange abstractly, for possible mapping to different formats, such as a text file, XML or a database. IFC, CIS/2 and ISO15926 are example exchange schemas.

**Feature**

As applied to design, a part of a shape with a specific purpose. In a CAD system, features are important because they have functional purposes; a connection is a feature on a steel beam and a window opening is a feature in a wall. Features may or may not be accessible, carry properties, or be editable. Feature-based design supports these capabilities.

**IFC (Industry Foundation Classes)**

An international public standard schema for representing building information. It uses ISO-STEP technology and libraries.

**Interoperability**

The ability of BIM tools from multiple vendors to exchange building model data and operate on that data. Interoperability is a significant requirement for team collaboration and data movement between different BIM platforms.

**ISO-STEP**

International Standards Organization - Standard for the Technical Exchange of Product Model Data; officially Technical Committee TC184 and a standard 10303 dealing with industrial automation. ISO-STEP provides the foundation technologies, tools and methods for developing interoperability tools and standards in manufacturing, aerospace, shipbuilding, and process and industrial plants. It is the technology basis for IFC, CIS/2 and many other exchange schemas and formats.

**Model server**

See BIM Server.

**Model Synchronization**

The issue of maintaining version consistency across all information in a BIM environment. This includes the methods to address this issue and deals with the issues of change management across multiple tools and platforms.

**Object Class**

In parametric modeling, object classes are the information structures for defining object instances. Architectural BIM design tools have object classes for Walls, Doors, Slabs, Windows, Roofs and so forth, while a structural BIM tool will have object classes for connections, rebar, pre-stress tendons and so forth. The object class defines how instances of a class are structured, how they are edited and how they behave when their context changes. Another name for object class is Object Family.

**Object-based Parametric Modeling**

The technology on which most BIM design applications are based. Includes the ability to define individual objects whose shape and other properties that can be controlled parametrically. It also applies to assemblies of objects, possibly up to the building scale that allows the assemblies to be controlled by parameters.

**Parametric Objects**

A limited form of parametric modeling, where a single object can be created or edited through its parameters. Parametric objects do not allow a user to compose an assembly of objects and the resulting assembly to then be updatable by a local or global change to parameters.

**Scalability**

The issue of how well a system behaves as the data it uses grows in size. Some applications operate well only with small datasets. File-based systems tend to have file size limitations while systems that use a database tend to be much less dependent on file size.

**Schema**

As applied to databases, the abstract representation or model of data for some use. SQL is a popular database language for creating and operating on database schemas.

**Solid modeling**

The general type of geometric modeling where the elements being modeled and operated on are closed and bounded, enclosing a volume. Solid modeling can represent solid shapes but also is misnamed because it can also represent the shapes of voids, such as a room. Solid modeling has multiple types of modeling within it, including B-rep, Constructive Solid Geometry, and Feature-based modeling.

**Transaction**

In databases, an operation on a database, that updates the data as a single step operation, similar to a “save” on a file system. Transactions may be user controlled or systems generated, and have as an important function maintaining the consistency of the data being stored.

**Workflow**

The sequences of task-related communication among people (normally the project team) to accomplish sequences of tasks and the needed data flows to support those sequences.



# Bibliography

---

- ACM (1969–1982). Annual Design Automation Conferences, ACM, NY.
- ADC (2010). “Cloudworx for AutoCAD,” Autodesk Developer Center Web page <http://usa.autodesk.com/adsk/servlet/item?siteID=123112&id=7141394&linkID=7138127>.
- AEX (2010). Automating Information Equipment Exchange (AEX), Roadmap Element 3, February, 2010, <http://fiatech.org/aex.html>, last accessed July, 2010.
- AGC (2006). *The Contractors’ Guide to Building Information Modeling*, Associated General Contractors of America. Arlington, VA.
- AIA (1994). *The Architect’s Handbook of Professional Practice*, Washington, D.C., AIA Document B162, American Institute of Architects.
- AISC (2007). *AISC Design Guide*, 20 vols. 2007 Edition, AISC Chicago, IL.
- Akintoye, A., and E. Fitzgerald (2000). “A Survey of Current Cost Estimating Practices in the UK,” *Construction Management & Economics* 18(2): 161–172.
- Alberti, L. B. (1987). *The Ten Books of Architecture: The 1755 Leoni Edition*. New York, (Paperback) Dover Press.
- Anderl, R., and R. Mendgen (1996). “Modeling with Constraints: Theoretical foundation and application,” *Computer-Aided Design* 28(3): 155–168.
- ANSI (1996). ANSI/BOMA Standard Method for Measuring Floor Area in Office Buildings; ANSI. Z65.1.
- Akinci, B., F. Boukamp, C. Gordon, D. Huber, C. Lyons, and K. Park (2006). “A Formalism for Utilization of Sensor Systems and Integrated Project Models for Active Construction Quality Control.” *Automation in Construction* 15(2): 124–138.
- American Institute of Architects (2006). “Business of Architecture: 2006 AIA Firm Survey.” Washington, D.C., AIA.
- Aram V., R. Sacks, I. Panushev, and M. Venugopal (2010). Introducing a New Methodology to Develop the Information Delivery Manual for AEC Projects, CIB W78 Conference Proc., Cairo.
- Arnold, J. A. (2007). “Tectonic Vision and Products.” Tectonic Networks Web site. [www.tectonicbim.com/](http://www.tectonicbim.com/).

- Ashcraft, H.W.J. (2006). "Building Information Modeling: A Great Idea in Conflict with Traditional Concepts of Insurance, Liability, and Professional Responsibility." Schinnerer's 45th Annual Meeting of Invited Attorneys.
- Autodesk (2004). "Return on Investment with Autodesk Revit." June 25, 2007. Autodesk Web site. Autodesk, Inc. [http://images.autodesk.com/adsk/files/4301694\\_Revit\\_ROI\\_Calculator.zip](http://images.autodesk.com/adsk/files/4301694_Revit_ROI_Calculator.zip)
- Autodesk (2007). "DWF: The Best File Format for Published Design." June 25, 2007. Autodesk DWF Community Web site. 2007. Autodesk, Inc. <http://usa.autodesk.com/adsk/servlet/item?siteID=125112&id=8675679>.
- Autodesk (2009). "Autodesk® Seek Metadata Style Guide," Draft Version 0.51 Release Date: 01/08/2009.
- BACnet (2010). BACnet—A Data Communication Protocol for Building Automation and Control Networks, SSPC 135, [www.bacnet.org/](http://www.bacnet.org/).
- Baer, A., C. Eastman, and M. Henrion (1979). "Geometrical Modeling: A survey." *Computer-Aided Design* 11(5): 253–272.
- Ballard, G. (1999). "Improving Work Flow Reliability," Proceedings IGLC-7, UC Berkeley, CA.
- Ballard, G. (2000). *The Last Planner™ System of Production Control*, Ph.D. Dissertation, University of Birmingham, Birmingham, U.K.
- Ballard, G., and P. Reiser (2004). "The St. Olaf College Field house Project: A case study in designing to Target Cost." 12th Annual Conference of the International Group for Lean Construction, Elsinor, Denmark, 2004, pp. 234–249.
- Ballard G., (2006). "Innovation in Design," PowerPoint Presentation at Lean Construction Web site. ([www.leanconstruction.org](http://www.leanconstruction.org)).
- Barak, R., Y.S. Jeong, R. Sacks, and C.M. Eastman (2009). "Unique Requirements of Building Information Modeling for Cast-in-Place Reinforced Concrete." *Journal of Computing in Civil Engineering*, 23(2), 64–74.
- Barton Malow (2006). General Motors Corporation, Global V6 Engine Facility. Barton Malow Web site. June 27, 2007. [www.bartonmalow.com/specialties/corporate/gmengine.htm](http://www.bartonmalow.com/specialties/corporate/gmengine.htm).
- Beard, J., M. Loulakis, and E. Wundram (2005). *Design-Build: Planning Through Development*, McGraw-Hill Professional.
- Bedrick (2008). "Organizing the Development of a Building Information Model," *AECbytes Feature*, Sept. 18, 2008. [www.aecbytes.com/feature/2008/MPSforBIM.html](http://www.aecbytes.com/feature/2008/MPSforBIM.html).
- Bijl, A., and G. Shawcross (1975). "Housing Site Layout System," *Computer-Aided Design* 7(1): 2–10.



- Birx, G. W. (2005). "BIM Evokes Revolutionary Changes to Architecture Practice at Ayers/Saint/Gross," *AIArchitect* 12/2005. June 29, 2007. [www.aia.org/aiarchitect/thisweek05/tw1209/tw1209changeisnow.cfm](http://www.aia.org/aiarchitect/thisweek05/tw1209/tw1209changeisnow.cfm).
- Bjork, B.C. (1995). *Requirements and Information Structures for Building Product Models*. Helsinki, VTT Technical Research Center of Finland.
- BLIS (2002). "Building Lifecycle Interoperable Software." BLIS project Web site. June 25, 2007. [www.blis-project.org/index2.html](http://www.blis-project.org/index2.html).
- Booch, G. (1993). *Object-Oriented Analysis and Design with Applications* (2d Edition), Addison-Wesley.
- Boryslawski, M. (2006). "Building Owners Driving BIM: The Letterman Digital Arts Center Story." *AECBytes*. Sept. 30 2006. 27 June 07. [www.aecbytes.com/buildingthefuture/2006/LDAC\\_story.html](http://www.aecbytes.com/buildingthefuture/2006/LDAC_story.html).
- Bozdoc, M. (2004). "The History of CAD." MB Solutions Web site. June 27, 2007. <http://mbinfo.mbdesign.net/CAD-History.htm>.
- Braid, I. C. (1973). *Designing with Volumes*. Cambridge UK, Cantab Press, Cambridge University.
- Brilakis, I., M. Lourakis, R. Sacks, S. Savarese, S. Christodoulou, J. Teizer, and A. Makhmalbaf (2009). "Automated Generation of Parametric BIMs Based on Hybrid Video and Laser Scanning," *Advanced Engineering Informatics*, Vol. 24 pp. 456–465.
- Brucker, B. A., M. P. Case, E. W. East, B. K. Huston, S. D. Nachtigail, J. C. Shockley, S. C. Spangler, and J. T. Wilson (2006). "Building Information Modeling (BIM): A Road Map for Implementation to Support MILCON Transformation and Civil Works Projects within the U.S. Army Corps of Engineers," U.S. Army Corps of Engineers, Engineer Research and Development Center.
- Busby, P., and R. Nutbrown (2008). "Autodesk® Seek Metadata Style Guide," Autodesk Inc., 73 pages. <http://seek.autodesk.com/AutodeskSeekMetadataStyleGuide.pdf>.
- Buswell, R. A., R.C. Soar, A.G.F. Gibb, and A. Thorpe (2007). "Freeform Construction: Mega-scale rapid manufacturing for construction," *Automation in Construction*, Vol. 16, No. 2, 2007, pp. 224–231.
- CAD (1976, 1978, 1980). Proceedings of CAD76, CAD78, CAD80, IPC Press, London.
- Caltech (1997). "Boeing 777: 100% Digitally Designed Using 3D Solids Technology." June 29, 2007. [www.cds.caltech.edu/conferences/1997/vecs/tutorial/Examples/Cases/777.htm](http://www.cds.caltech.edu/conferences/1997/vecs/tutorial/Examples/Cases/777.htm).
- Campbell, D. A. (2006). "Modeling Rules," *Architecture Week*, [www.architectureweek.com/2006/1011/tools\\_1-1.html](http://www.architectureweek.com/2006/1011/tools_1-1.html).

- Cavieres, A., R. Gentry, and T. Al-Haddad (2009). Rich Knowledge Parametric Tools for Concrete Masonry Design: Automation of Preliminary Structural Analysis, Detailing and Specification; Proceedings of the 2009 26th International Symposium on Automation and Robotics in Construction (ISARC), Austin, TX, June 24–27, 2009, pp. 544–552.
- Chan, A., D. Scott, and E. Lam (2002). “Framework of Success Criteria for Design/Build Projects,” *Journal of Management in Engineering* 18(3): 120–128.
- CIFE (2006). Unpublished PDF Report: 2006\_CIFE\_Case Report Helsinki Music\_CenterCIS/2 (2007).
- “CIMSTEEL Integration Standards.” Steel Construction Institute. June 5, 2007. [www.cis2.org/CityGML\(2010\)](http://www.cis2.org/CityGML(2010)) “Virtual 3D City Models”, [www.citygml.org/](http://www.citygml.org/).
- Cloudworx (2002). “Cloudworx”, *CAD User AEC Magazine*, Vol. 15, No. 05, May 2002, [www.caduser.com/reviews/reviews.asp?a\\_id=139](http://www.caduser.com/reviews/reviews.asp?a_id=139).
- Cohen, J. (2010). “Integrated Project Delivery: Case Studies,” AIA California Council IPD Steering Committee.
- Construction Clients Forum (1997). “60% of Clients Dissatisfied.” *Building*, 8.
- CORENET (2007). “Integrated Plan Checking Systems.” CORENET. Nov. 14, 2006. June 5, 2007. [www.corenet.gov.sg/](http://www.corenet.gov.sg/).
- Court, P., C. Pasquire, A. Gibb, and D. Bower (2006). “Design of a Lean and Agile Construction System for a Large and Complex Mechanical and Electrical Project,” *Understanding and Managing the Construction Process: Theory and Practice, Proceedings of the 14th Conference of the International Group for Lean Construction*, R. Sacks and S. Bertelsen, eds., Catholic University of Chile, School of Engineering, Santiago, Chile, 243–254.
- Crowley, A. (2003). “CIS/2 Interactive at NASCC,” *New Steel Construction* 11:10.
- CSIRO (2007). “Building & Construction.” CSIRO. June 27, 2007. [www.csiro.au/science/ps2oz.html](http://www.csiro.au/science/ps2oz.html).
- Dakan, M. (2006). “GSA’s BIM Pilot Program Shows Success.” *Cadalyst*. July 19, 2006. June 27, 2007. <http://aec.cadalyst.com/aec/article/articleDetail.jsp?id=359335>.
- Day, M. (2002). “Intelligent Architectural Modeling.” *AEC Magazine*, September 2002. June 27, 2007. [www.caddigest.com/subjects/aec/select/Intelligent\\_modeling\\_day.htm](http://www.caddigest.com/subjects/aec/select/Intelligent_modeling_day.htm).
- Debella, D. and R. Ries (2006). “Construction Delivery Systems: A Comparative Analysis of Their Performance within School Districts.” *Journal of Construction Engineering and Management*, 132(11): 1131–1138.

- Demkin, J. (2001). *Architect's Handbook of Professional Practice*. New York, John Wiley and Sons.
- Department of Defense (2000). *Guidebook for Performance-Based Services Acquisition (PBSA)*. Defense Acquisition University Press, Washington, D.C.
- Ding, L., R. Drogemuller, M. Rosenman, D. Marchant, and J. Gero (2006). "Automating Code Checking for Building Designs – DesignCheck. Clients Driving Innovation: Moving Ideas into Practice". K. Brown, K. Hampson, and P. Brandon. Sydney, Australia, CRC for Construction Innovation for Icon.Net Pty Ltd.
- Dolan, T. G. (2006). "First Cost vs. Life-Cycle Costs: Don't get caught in the trap of saving now to pay later." *School Planning and Management*. January 2006.
- Douglas Steel (2007). "General Motors V-6 Engine Plant." Douglas Steel Fabricating Corporation. June 27, 2007. <http://douglassteel.com/gmv6.htm>.
- East, W. (2007). Construction Operations Building Information Exchange (COBie); Requirements Definition and Pilot Implementation Standard, ERDC/CERL TR-07-30, August 2007
- Eastman, C. M. (1975). "The Use of Computers Instead of Drawings in Building Design." *Journal of the American Institute of Architects*, March: 46–50.
- Eastman, C. M. (1980). "Prototype Integrated Building Model," Proceedings of CAD80, IPC Press, London, (1980).
- Eastman, C. M. (1992). "Modeling of Buildings: Evolution and concepts." *Automation in Construction 1*: 99–109.
- Eastman, C. M., I. His, and C. Potts (1998). Coordination in Multi-Organization Creative Design Projects. Design Computing Research Report. Atlanta, GA, College of Architecture, Georgia Institute of Technology.
- Eastman, C. M. (1999). *Building Product Models: Computer environments supporting design and construction*. Boca Raton, FL, CRC Press.
- Eastman, C. M., R. Sacks, and G. Lee (2001). Software Specification for a Precast Concrete Design and Engineering Software Platform. Atlanta, GA, Georgia Institute of Technology.
- Eastman, C. M., R. Sacks, and G. Lee (2002). "Strategies for Realizing the Benefits of 3D Integrated Modeling of Buildings for the AEC Industry" ISARC—19th International Symposium on Automation and Robotics in Construction, Washington, D.C., NIST.
- Eastman, C.M., R. Sacks, and G. Lee (2003). "Development and Implementation of Advanced IT in the North American Precast Concrete Industry," *ITCON—Electronic Journal of Information Technology in Construction*, Vol. 8, pp. 247–262.

- Eastman, C. M., P. Teicholz, R. Sacks, and K. Liston (2008). *BIM Handbook: A Guide to Building Information Modeling for Owners, Managers, Architects, Engineers, Contractors and Fabricators*, John Wiley and Sons, Hoboken, NJ, 495 pages.
- Eastman, C. M., J. Lee, Y. Jeong, and J. Lee (2009). "Automatic Rule-Based Checking of Building Designs." *Automation in Construction*, Vol. 18, pp. 219–238.
- Eastman, C., R. Sacks, I. Panushev, V. Aram, and E. Yagmur (2009a). *Information Delivery Manual for Precast Concrete*. PCI-Charles Pankow Foundation. [http://dcom.arch.gatech.edu/pcibim/documents/IDM\\_for\\_Precast.pdf](http://dcom.arch.gatech.edu/pcibim/documents/IDM_for_Precast.pdf) (last accessed on 6/20/2010).
- Eastman, C., Y.-S. Jeong, R. Sacks, and I. Kaner (2010a). "Exchange Model and Exchange Object Concepts for Implementation of National BIM Standards," *Journal of Computing in Civil Engineering*, 24:1 (25).
- Eastman, C., R. Sacks, I. Panushev, M. Venugopal, and V. Aram (2010b). "Precast Concrete BIM Standard Documents: Model View Definitions for Precast Concrete." PCI-Charles Pankow Foundation. [http://dcom.arch.gatech.edu/pcibim/documents/Precast\\_MVDs\\_v2.1\\_Volume\\_I.pdf](http://dcom.arch.gatech.edu/pcibim/documents/Precast_MVDs_v2.1_Volume_I.pdf) (last accessed on 6/20/2010).
- Emkin, L. (1988). Computers in Structural Engineering Practice: The issue of quality Computers and Structures, 30:3, 439–446.
- Ergen, E., B. Akinci, and R. Sacks (2007). "Tracking and Locating Components in a Precast Storage Yard Utilizing Radio Frequency Identification Technology and GPS." *Automation in Construction* 16: 354–367.
- Evey, L. (2006). Conversation between P. Teicholz and Lee Evey, President, Design-Build Institute of America.
- FIATECH (2007). *aecXML*. FIATECH. June 27, 2007. [www.fiatech.org/projects/idim/aecxml.htm](http://www.fiatech.org/projects/idim/aecxml.htm).
- FIATECH (2010). *Capital Projects Technology Roadmap*. <http://fiatech.org/capital-projects-technology-roadmap.html>.
- FMI/CMAA (2005, 2006). "FMI/CMAA Annual Survey of Owners." FMI/CMAA Web sites.
- Folkestad, J. E. and D. Sandlin (2003). "Digital Construction: Utilizing three dimensional (3D) computer models to improve constructability." Colorado State University. June 27, 2007; [www.cm.caahs.colostate.edu/Faculty\\_and\\_Staff/folkestad/PDF/Folkestad%20&%20Sandlin%20IEMS%202005.pdf](http://www.cm.caahs.colostate.edu/Faculty_and_Staff/folkestad/PDF/Folkestad%20&%20Sandlin%20IEMS%202005.pdf).
- Frampton, K. and J. Cava (1996). *Studies in Tectonic Culture: The Poetics of Construction in Nineteenth and Twentieth Century Architecture*. Cambridge, MA, The MIT Press.

- Francis R. (1992). *Facility Layout and Location: An Analytical Approach*, Englewood Cliffs, NJ, Prentice-Hall.
- Gaddie, S. (2003). "Enterprise Programme Management: Connecting strategic planning to project delivery." *Journal of Facilities Management* 2(2): 177–191.
- Gallaher, M. P., A. C. O'Connor, J. John, L. Dettbarn, and L. T. Gilday (2004). Cost Analysis of Inadequate Interoperability in the U.S. Capital Facilities Industry. Gaithersburg, MD, National Institute of Standards and Technology, U.S. Department of Commerce Technology Administration.
- GBXML n.d. gbXML Web site home: [www.gbxml.org/](http://www.gbxml.org/).
- Geertsema, C., G. E. Gibson, Jr., and D. Ryan-Rose (2003). Emerging Trends of the Owner-Contractor Relationship for Capital Facility Projects from the Contractor's Perspective. Center for Construction Industry Studies Report. University of Texas at Austin. Report No. 8. [www.ce.utexas.edu/org/ccis/a\\_ccis\\_report\\_32.pdf](http://www.ce.utexas.edu/org/ccis/a_ccis_report_32.pdf)
- Gerber, D., B. Becerik, and A. Kunz (2010). "Building Information Modeling and Lean Construction: Technology, Methodology and Advances from Practice," Proceedings of the 18th Annual Conference of the International Group for Lean Construction, Haifa, Israel, July 2010, Walsh, K., and T. Alves (eds), pp. 683–693.
- Gielingh, W. (1988). "General AEC Reference Model (GARM)," *Conceptual Modeling of Buildings*, CIB W74–W78 Seminar, Lund, Sweden, CIB Publication 126.
- Goldstein, H. (2001). "4D: Science Fiction or Virtual Reality," *Engineering News Record*. April 16, 2001.
- Gonchar, J. (2007). "To Architects, Building Information Modeling Is Still Primarily a Visualization Tool." *Architectural Record*. July 27, 2007. <http://archrecord.construction.com/features/digital/archives/0607dignews-2.asp>.
- Gray J. and A. Reuter, *Transaction Processing: Concepts and Techniques*, Morgan Kaufmann; (September 15, 1992).
- Green Building Studio (2004). "AEC Design Practice Survey Identifies Opportunities to Accelerate 3D-CAD/BIM Adoption and Green Building Design." June 25, 2007. [www.greenbuildingstudio.com/gbsinc/pressrelease.aspx?id=24](http://www.greenbuildingstudio.com/gbsinc/pressrelease.aspx?id=24).
- Green Building Studio (2007). "Green Building XML Schema" from [www.gbxml.org/index.htm](http://www.gbxml.org/index.htm).
- Grohoski, C. (2006). "Virtual Reality Isn't Just for Gamers Anymore." *Webwire*. June 27, 2006. June 29, 2007. [www.webwire.com/ViewPressRel.aspx?aId=15849](http://www.webwire.com/ViewPressRel.aspx?aId=15849).

- GSA (2006). 02—GSA BIM Guide For Spatial Program Validation Version 0.90. Washington, D.C., United States General Services Administration: 61.
- GSA (2006a). “3D-4D Building Information Modeling.” GSA. June 27, 2007. [www.gsa.gov/bim](http://www.gsa.gov/bim).
- GSA (2007). “GSA Performance-Based Acquisition.” GSA. June 27, 2007. [www.gsa.gov/Portal/gsa/ep/channelView.do?pageTypeId=8203&channelPage=%252Fep%252Fchannel%252FgsaOverview.jsp&channelId=13077](http://www.gsa.gov/Portal/gsa/ep/channelView.do?pageTypeId=8203&channelPage=%252Fep%252Fchannel%252FgsaOverview.jsp&channelId=13077).
- GT-COA (2007). “GSA Project—BIM Enabled Design Guide Automation.” *GT Design Computing*. June 27, 2007 <http://dcom.arch.gatech.edu/gsa/>.
- Hänninen, R. (2007). “Performance Metrics for Demand and Supply in the Building Lifecycle Process.” Presentation available online at: [www.uni-weimar.de/icccbe/late/icccbe-x\\_050.pdf](http://www.uni-weimar.de/icccbe/late/icccbe-x_050.pdf).
- Haymaker, J., and M. Fischer (2001). “Challenges and Benefits of 4D Modeling on the Walt Disney Concert Hall Project.” Working Paper Nr. 64, CIFE, 17 pages.
- Hendrickson, C. (2003). *Project Management for Construction: Fundamental Concepts for Owners, Engineers, Architects and Builders* Version 2.1. June 27, 2007, [www.ce.cmu.edu/pmbook](http://www.ce.cmu.edu/pmbook).
- Hodges, C., and W. W. Elvey (2005). “Making the Business Case for Sustainability: It’s Not Just About Getting Points.” *Facilities Manager* 21(4): 50–53.
- Hopp, W. J., and M. L. Spearman (1996). *Factory Physics*. Chicago, Irwin.
- Hospitals, V. (2007). “Dept. of Veterans Affairs.” from [www.va.gov/facmgt/cost-estimating/](http://www.va.gov/facmgt/cost-estimating/).
- Houbaux, P. (2005). The SABLE Project: Towards Unification of IFC-based Product Model Servers, IAI-Iberia Industry Day, Madrid.
- Howell, G. A. (1999). “What Is Lean Construction—1999?” Seventh Annual Conference of the International Group for Lean Construction, IGLC-7, Berkeley, CA.
- Huang, T., H. Li, H. Guo, N. Chan, S. Kong, and M. Skitmore (2009). “Construction Virtual Prototyping: A survey of use.” *Construction Innovation: Information, Process, Management*, 9(4).
- IAI (2010). “BuildingSMART and Interoperability.” Industry Alliance for Interoperability. June 18, 2007, [www.buildingsmart.com/](http://www.buildingsmart.com/).
- IAI (2010a). “IFC/ifcXML Specifications.” [www.iai-tech.org/products/ifc\\_specification/ifcxml-releases/summary](http://www.iai-tech.org/products/ifc_specification/ifcxml-releases/summary).
- Ibbs, C. W., Y. H. Kwak, T. Ng, and A. M. Odabasi (2003). “Project Delivery Systems and Project Change: Quantitative analysis.” *Journal of Construction Engineering and Management* 129(4): 382–387.

- ICC (2007). "SMARTcodes™." International Code Council. June 30, 2007, [www2.iccsafe.org/io/smartcodes/](http://www2.iccsafe.org/io/smartcodes/).
- Jackson, E., (2000). Prototype Practice for the Building Industry: Operation and Maintenance Support Information. Linking the Construction Industry: Electronic Operation and Maintenance Manuals: Workshop Summary (2000), Federal Facilities Council.
- Jackson, S. (2002). "Project cost overruns and risk management." Proceedings of the 18th Annual ARCOM Conference, Glasgow.
- Jacobs, G. (2010). "3D Laser Scanning Reduces Risks," *Reporter—The Global Magazine of Leica Geosystems*, No 62, April 2010. [www.leica-geosystems.com/en/Customer-Magazine\\_81593.htm](http://www.leica-geosystems.com/en/Customer-Magazine_81593.htm).
- J.E. Dunn (2007). "Building Information Modeling Specialist" from [www.kcrevit.com/Job\\_Postings\\_Main.htm](http://www.kcrevit.com/Job_Postings_Main.htm).
- Johnston, G. B. (2006). "Drafting Culture: A social history of architectural graphic standards." Ph.D. Thesis, Emory University, Atlanta.
- Jørgensen, K., J. Skauge, P. Christiansson, K. Svidt, K-B. Sørensen, and J. Mitchell (2008). Use of IFC Model Servers: *Modelling Collaboration Possibilities in Practice*, Aalborg University, [www.re-ad.dk/files/74831/ReportIfcModelServer-Final.pdf](http://www.re-ad.dk/files/74831/ReportIfcModelServer-Final.pdf), last accessed Oct. 16, 2010.
- Kalay, Y. (1989). *Modeling Objects and Environments*. New York, John Wiley & Sons.
- Karola, A., H. Lahtela, R. Hänninen, R. Hitchcock, Q. Chen, S. Dajka, and K. Hagström (2002). BSPRo COM-Server-Interoperability Between Software Tools Using Industry Foundation Classes, *Energy and Building*, 34, pp. 901–907.
- Khanzode, A., M. Fischer, and D. Reed (2007). "Challenges and benefits of implementing virtual design and construction (VDC) technologies for coordination of mechanical, electrical and plumbing (MEP) systems on a large healthcare project." Proceedings of the 24th CIB–W78 Conference titled "Bringing ITC to Work" held in Maribor, Ed: Danijel Rebolj, Slovenia, June 26–29, 2007. pp. 205–212.
- Khemlani, L. (2004). "The IFC Building Model: A Look Under the Hood." March 30, 2004. *AECbytes*. June 15, 2007, [www.aecbytes.com/feature/2004/IFCmodel.html](http://www.aecbytes.com/feature/2004/IFCmodel.html).
- Khemlani, L. (2005). "CORENET e-PlanCheck: Singapore's Automated Code Checking System." October 26, 2005. *AECbytes*. June 30, 2007, [www.aecbytes.com/buildingthefuture/2005/CORENETePlanCheck.html](http://www.aecbytes.com/buildingthefuture/2005/CORENETePlanCheck.html)
- Khemlani, L. (2006). "AIA CBSP Symposium on BIM for Building Envelope Design and Performance." Nov. 15, 2006. *AECbytes*. June 28, 2007, [www.aecbytes.com/buildingthefuture/2006/AIA-CBSP\\_BIM.html](http://www.aecbytes.com/buildingthefuture/2006/AIA-CBSP_BIM.html).

- Khemplani, L. (2006). "Use of BIM by Facility Owners: An 'Expositions' Meeting." May 16, 2006. *AECbytes*. June 27, 2007, [www.aecbytes.com/buildingthefuture/2006/Expotitions\\_meeting.html](http://www.aecbytes.com/buildingthefuture/2006/Expotitions_meeting.html).
- Khemplani, L. (2005). "Multi-Disciplinary BIM at Work at GHAFARI Associates." Nov. 21, 2005. *AECbytes*. June 27, 2007, [www.aecbytes.com/buildingthefuture/2006/BIM\\_Awards.html](http://www.aecbytes.com/buildingthefuture/2006/BIM_Awards.html).
- Khemplani, L. (2006). "2006 2nd Annual BIM Awards Part 1." July 12, 2006. *AECbytes*. June 28, 2007, [www.aecbytes.com/buildingthefuture/2006/BIM\\_Awards.html](http://www.aecbytes.com/buildingthefuture/2006/BIM_Awards.html)
- Kieran, S., and J. Timberlake (2003). *Refabricating Architecture: How Manufacturing Methodologies are Poised to Transform Building Construction*. New York, McGraw-Hill Professional.
- Koerckel, A. and G. Ballard (2005). "Return on Investment in Construction Innovation—A Lean Construction Case Study." Proceedings of the 14th Conference of the International Group for Lean Construction, Sydney, Australia.
- Konchar, M., and V. Sanvido (1998). "Comparison of U.S. Project Delivery Systems." *Journal of Construction Engineering and Management* 124(6): 435–444.
- Koo, B., and M. Fischer (2000). "Feasibility Study of 4D CAD in Commercial Construction." *Journal of Construction Engineering and Management*, 126 (5): 251–260.
- Koskela, L. (1992). *Application of the New Production Philosophy to Construction*, Technical Report #72, Center for Integrated Facility Engineering, Department of Civil Engineering, Stanford University.
- Krause, B. (2010). Personal communication 6/29/2010 from Brian Krause, VDC, Turner Construction Company Regional Manager.
- Kunz, J., and M. Fischer (2007). *Virtual Design and Construction: Themes, Case Studies and Implementation Suggestions*, Center for Integrated Facility Engineering, Stanford University.
- Laine, T., E. Reinikainen, K. Liljeström, and A. Karola (2001). *Integrated LCA-Tool for Ecological Design*, *Seventh International IBPSA Conference*, Rio de Janeiro, Brazil, August 13–15, 2001, pp. 739–746.
- Laiserin, J. (2009). "Next-Gen BIM: Graphisoft Teamwork 2.0 Will Revolutionize BIM/IPD Workflow and Collaboration," Laiserin Letter, Special Edition, July 25, 2009.
- Laurenzo, R. (2005). "Leaning on Lean Solutions," *Aerospace America*, June 2005: 32–36.
- Lee, J-K, J. Lee, Y-S Jeong, H. Sheward, P. Sanguinetti, S. Abdelmohsen, and C. Eastman (2010). "Development of Space Object Semantics for



- Automated Building Design Review Systems,” Design Computation working paper, Digital Building Lab, July, 2010.
- Lipman, R. R. (2004). “Mobile 3D Visualization for Steel Structures.” *Automation in Construction* 13(1): 119–125.
- Liston, K., J. Kunz, and M. Fischer (2000). “Requirements and Benefits of Interactive Information Workspaces in Construction,” Proceedings of the Eighth International Conference on: Computing in Civil and Building Engineering (ICCCBE-VIII), Renate Fruchter, Feniosky Pena-Mora, and W.M. Kim Roddis (eds.), Stanford, CA, 2:1277–1284.
- Liston, K., M. Fischer, and T. Winograd (2001). “Focused Sharing of Information for Multidisciplinary Decision Making by Project Teams.” *ITCon (Electronic Journal of Information Technology in Construction)* 6: 69–81.
- Ma, Z., Q. Shen, and J. Zhang (2005). “Application of 4D for Dynamic Site Layout and Management of Construction Projects.” *Automation in Construction* 14(3): 369–381.
- Majumdar, T., M. Fischer, and B. R. Schwegler (2006). “Conceptual Design Review with a Virtual Reality Mock-Up Model,” Joint International Conference on Computing and Decision Making in Civil and Building Engineering, Montreal.
- McDuffie, T. (2007). “BIM: Transforming a Traditional Practice Model into a Technology-Enabled Integrated Practice Model.” *AIA Cornerstone*. [www.aia.org/nwsltr\\_pa.cfm?pagename=pa\\_a\\_200610\\_bim](http://www.aia.org/nwsltr_pa.cfm?pagename=pa_a_200610_bim).
- McGraw-Hill (2009). McGraw-Hill Construction SmartMarket Report: The Business Value of BIM, McGraw-Hill Construction Research and Analytics.
- McKinney, K., J. Kim, M. Fischer, and C. Howard (1996). “Interactive 4D-CAD.” Proceedings of the Third Congress on Computing in Civil Engineering, Jorge Vanegas and Paul Chinowsky (Eds.), ASCE, Anaheim, CA, 383–389.
- McKinney, K., and M. Fischer (1998). “Generating, Evaluating and Visualizing Construction Schedules with 4D-CAD Tools.” *Automation in Construction* 7(6): 433–447.
- McNair, S., and M. Flynn (2006). “Managing an Ageing Workforce in Construction.” Leicester, Department for Work and Pensions Centre for Research into the Older Workforce.
- Mitchell, J., and H. Schevers (2005). “Building Information Modelling for FM at Sydney Opera House.” CRC Construction Innovation, CRC-CI Project 2005–001-C Report No: 2005–001-C-4.
- Moore, G. A. (1991). *Crossing the Chasm*, New York, Harper Business.

- Morgan, M. H. (1960). *Vitruvius—The Ten Books of Architecture*, New York, Dover Press. See esp. Book 1, Chapter 2, Section 2.
- Munroe, C. (2007). “Construction Cost Estimating.” American Society of Professional Estimators, June 27, 2007, [www.aspenational.com/CONSTRUCTION%20Cost%20ESTIMATING.pdf](http://www.aspenational.com/CONSTRUCTION%20Cost%20ESTIMATING.pdf)
- NASA (1978–1980). Conference on Engineering and Scientific Data Management, Hampton, VA, NASA.
- National Research Council (1998). *Stewardship of Federal Facilities: A Proactive Strategy for Managing the Nation’s Public Assets*. National Academy Press, Washington, D.C.
- NIBS (2008). *United States National Building Information Modeling Standard, version 1—Part 1: Overview, principles, and methodologies*. <http://nbimsdoc.opengeospatial.org/> Oct. 30, 2009.
- NIST and Fiatch (2006). “Capital Facilities Information Handover Guide, Part 1.”
- NISTIR 7259. Department of Commerce. June 27, 2007, [www.fire.nist.gov/bfrlpubs/build06/PDF/b06016.pdf](http://www.fire.nist.gov/bfrlpubs/build06/PDF/b06016.pdf).
- Oberlender, G., and S. Trost (2001). “Predicting Accuracy of Early Cost Estimates Based on Estimate Quality.” *Journal of Construction Engineering and Management* 127(3): 173–182.
- O’Connor, J. T., and S. C. Dodd (1999). “Capital Facility Delivery with Enterprise Resource Planning Systems.” Center for Construction Industry Studies Report. University of Texas at Austin. Report No. 16.
- OmniClass (2007). “OmniClass: A Strategy for Classifying the Built Environment,” OmniClass. June 30, 2007, [www.omniclass.org/](http://www.omniclass.org/).
- Onuma, K. G. and D. Davis (2006). “Integrated Facility Planning Using BIM Web Portals.” Oct. 9, 2006, from Federal Facilities Council, June 30, 2007, [www.onuma.com/services/FederalFacilitiesCouncil.php](http://www.onuma.com/services/FederalFacilitiesCouncil.php).
- P100, (2005). The Facilities Standards for the Public Buildings Service, downloadable from [www.gsa.gov/portal/category/21568](http://www.gsa.gov/portal/category/21568).
- Pasquire, C., R. Soar, and A. Gibb (2006). “Beyond Pre-Fabrication—The Potential of Next Generation Technologies to Make a Step Change in Construction Manufacturing,” *Understanding and Managing the Construction Process: Theory and Practice, Proceedings of the 14th Conference of the International Group for Lean Construction* R. Sacks and S. Bertelsen, eds., Catholic University of Chile, School of Engineering, Santiago, Chile, 243–254.
- Pixley, D., J. Holm, K. Howard, and G. Zettel (2006). “A Look at Sutter’s Lean Program.” LCI Congress, Lean Construction Institute.

- PCI (2004). *Design Handbook of Precast and Prestressed Concrete*. Skokie, IL, Precast/Prestressed Concrete Institute.
- Post, N. M. (2002). "Movie of Job That Defies Description Is Worth More Than a Million Words." *Engineering News Record*, April 8, 2002.
- Ramsey, G. and H. Sleeper (2000). *Architectural Graphic Standards*. New York, John Wiley & Sons.
- Requicha, A. (1980). "Representations of Rigid Solids: Theory, methods and systems." *ACM Computer Surv* 12(4): 437–466.
- Robbins, E. (1994). *Why Architects Draw*. Cambridge, MA, MIT Press.
- Roe, A. (2002). "Building Digitally Provides Schedule, Cost Efficiencies: 4D CAD is expensive but becomes more widely available." *Engineering News Record*, February 25, 2002.
- Roe, A. (2006). "The Fourth Dimension is Time" *Steel*, Australia, 15.
- Romm, J. R. (1994). *Lean and Clean Management: How to Boost Profits and Productivity by Reducing Pollution*, Kodansha International.
- Roodman, D. M., and N. Lenssen (1995). *A Building Revolution: How Ecology and Health Concerns Are Transforming Construction*, Worldwatch Institute.
- Rozenfeld, O., R. Sacks, and Y. Rosenfeld (2009). "CHASTE—Construction Hazard Analysis with Spatial and Temporal Exposure," *Construction Management & Economics*, Vol. 27 No. 7, pp. 625–638.
- Rundell, R. (2006). "1–2–3 Revit: BIM and Cost Estimating, Part 1: How BIM can support cost estimating." *Cadalyst*, August 7, 2006.
- Sacks, R., C. M. Eastman, and G. Lee (2003). "Process Improvements in Precast Concrete Construction Using Top-Down Parametric 3-D Computer-Modeling." *Journal of the Precast/Prestressed Concrete Institute* 48(3): 46–55.
- Sacks, R. (2004). "Evaluation of the Economic Impact of Computer-Integration in Precast Concrete Construction." *Journal of Computing in Civil Engineering* 18(4): 301–312.
- Sacks, R., and R. Barak (2007). "Impact of Three-Dimensional Parametric Modeling of Buildings on Productivity in Structural Engineering Practice." *Automation in Construction* (2007), doi:10.1016/j.autcon.2007.08.003.
- Sacks, R., and R. Barak (2010). "Teaching Building Information Modeling as an Integral Part of Freshman Year Civil Engineering Education," *Journal of Professional Issues in Engineering Education and Practice*, Vol. 136, No. 1 pp. 30–38.
- Sacks, R., L. Koskela, B. Dave, and R. L. Owen (2010). "The Interaction of Lean and Building Information Modeling in Construction," *Journal of Construction Engineering and Management*, Vol. 136, No. 9 pp. 968–980.

- Sacks, R., M. Radosavljevic, and R. Barak (2010). "Principles for Building Information Modeling Based Lean Production Management Systems for Construction," *Automation in Construction*, Vol. 19, No. 5, pp. 641–655.
- Sanvido, V., and M. Konchar (1999). *Selecting Project Delivery Systems, Comparing Design-Build, Design-Bid-Build, and Construction Management at Risk*, Project Delivery Institute, State College, PA.
- Sawyer, T. (2006). "Early Adopters Find the Best Models Are Digital Virtuosos." *Engineering News Record*, October 2, 2006.
- Sawyer, T. (2008). "\$1-Billion Jigsaw Puzzle Has Builder Modeling Supply Chains," *Engineering News Record*, April 2008.
- Sawyer, T., and T. Grogan (2002). "Finding the Bottom Line Gets a Gradual Lift from Technology." *Engineering News Record*, August 12, 2002.
- Schenck, D. A., and P. R. Wilson (1994). *Information Modeling the EXPRESS Way*. New York, Oxford University Press.
- Schodek, D., M. Bechthold, K. Griggs, K. M. Kao, and M. Steinberg (2005). *Digital Design and Manufacturing, CAD/CAM Applications in Architecture and Design*. New York, John Wiley & Sons.
- Schwegler, B., M. Fischer, and K. Liston (2000). "New Information Technology Tools Enable Productivity Improvements." North American Steel Construction Conference, Las Vegas, AISC.
- SERA (2010). Courtyard LEED Certification Case Study elaborated by SERA Architects; [http://ideateinc.com/ideas/case\\_studies/aec/SERA\\_Marriott\\_Green.pdf](http://ideateinc.com/ideas/case_studies/aec/SERA_Marriott_Green.pdf).
- Shah, J. J., and M. Mantyla. (1995). *Parametric and Feature-Based CAD/CAM: Concepts, Techniques, and Applications*. New York: John Wiley & Sons.
- Shepherd, Paul, and Roly Hudson. Parametric Definition of Lansdowne Road Stadium. Internal report, University of Bath. Bath, UK, 2008. 1–10.
- Sheppard, L. M. (2004). "Virtual Building for Construction Projects," *IEEE Computer Graphics and Applications*, January 6–12.
- Smoot, B. (2007). Building Acquisition and Ownership Costs. CIB Workshop, CIB.
- Stephens, S. (2007). "Crowding the Marquee." *Architectural Record*, January 2007, June 30, 2007. <http://archrecord.construction.com/practice/firmCulture/0701crowding-1.asp>.
- Still, K. (2000). *Crowd Dynamics*. Ph.D. Thesis. University of Warwick, Department of Mathematics.
- Sullivan, C. C. (2007). "Integrated BIM and Design Review for Safer, Better Buildings: How project teams using collaborative design reduce risk,

- creating better health and safety in projects.” *McGraw-Hill Construction Continuing Education*. June 27, 2007. <http://construction.com/CE/articles/0706navis-1.asp>.
- Teicholz, E. (2004). “Bridging the AEC/FM Technology Gap.” *IFMA Facility Management Journal*, Apr/Mar 2004.
- Thomas, H. R., C. Korte, V. E. Sanvido, and M. K. Parfitt (1999). “Conceptual Model for Measuring Productivity of Design and Engineering.” *Journal of Architectural Engineering* 5(1): 1–7.
- Thomson, D., and R. Miner (2006). “Building Information Modeling—BIM: Contractual Risks Are Changing with Technology.” *The Construction Law Briefing Paper*. June 27, 2007, [www.aepronet.org/ge/no35.html](http://www.aepronet.org/ge/no35.html).
- TNO (2007). “Knowledge for Business.” from [www.ifcbrowser.com/](http://www.ifcbrowser.com/).
- Touran, A. (2003). “Calculation of Contingency in Construction Projects.” *IEEE Transactions on Engineering Management* 50(2): 135–140.
- Tulacz, G. J. (2006). “The Top Owners.” *Engineering News Record*, Nov. 27, 2006.
- U.S. Courts Design Guide (2007). Administrative Office of the U.S. Courts, Space and Facilities Division, [www.gsa.gov/Portal/gsa/ep/contentView.do?P=PME&contentId=15102&contentType=GSA\\_DOCUMENT](http://www.gsa.gov/Portal/gsa/ep/contentView.do?P=PME&contentId=15102&contentType=GSA_DOCUMENT), 2007.
- U.S. (2004, May 26, 2005). “2002 Economic Census Industry Series Reports Construction.” 2002 Economic Census from [www.census.gov/econ/census02/guide/INDRPT23.HTM](http://www.census.gov/econ/census02/guide/INDRPT23.HTM).
- U.S. Department of Energy (DOE) (1997). “Cost Estimating Guide.” DOE G 430.1–1, Washington, D.C.: Chapter 11. United States. Department of Energy (1997). “Cost Estimating Guide.” DOE G 430.1–1, Washington, D.C.: Chapter 11.
- U.S. Department of Energy (DOE) and I. P. Public Technology (1996). “*The Sustainable Building Technical Manual: Green Building Design, Construction, and Operations*.” Washington, D.C., U.S. Department of Energy: 34.
- USDOT—Federal Highway Administration (2006). “Design-Build Effectiveness Study.” USDOT Final Report. June 27, 2007, [www.fhwa.dot.gov/reports/designbuild/designbuild.htm](http://www.fhwa.dot.gov/reports/designbuild/designbuild.htm).
- Warne, T., and J. Beard (2005). *Project Delivery Systems: Owner’s Manual*, American Council of Engineering Companies, Washington, D.C.
- Weaire, D., and R. Phelan (1994). “A Counterexample to Kelvin’s Conjecture on Minimal Surfaces.” *Phil. Mag. Lett.* 69:107–110.
- Womack, J. P., and D. T. Jones (2003). *Lean Thinking: Banish Waste and Create Wealth in Your Corporation*. New York, Simon & Schuster.

- Yaski, Y. (1981). *A Consistent Database for an Integrated CAAD System*. PhD Thesis, Carnegie Mellon University, Pittsburgh, PA.
- Yeh, I.-C. (2006). Architectural Layout Optimization Using Annealed Neural Network, *Automation in Construction*, 15:4, July 2006, pp. 531–539.
- Young, N., S. Jones, and H.M. Bernstein (2008). *Building Information Modeling: Transforming Design and Construction to Achieve Greater Industry Productivity*, McGraw-Hill Construction, New York.
- Young, N., S. Jones, H.M. Bernstein, and J.E. Gudgel (2009). *The Business Value of BIM: Getting BIM to the Bottom Line*, McGraw-Hill Construction, New York.

## ORGANIZATION WEB SITES

- AGC (2010). Associated General Contractors, [www.agc.org/](http://www.agc.org/).
- AIA (2010). American Institute of Architects, [www.aia.org/index.htm](http://www.aia.org/index.htm).
- AISC (2007). American Institute of Steel Construction, [www.aisc.org/](http://www.aisc.org/).
- BCA (2010). Building Commissioning Association, [www.bcxa.org/](http://www.bcxa.org/).
- CIFE (2007). Center for Integrated Facility Engineering, [www.stanford.edu/group/CIFE/](http://www.stanford.edu/group/CIFE/).
- CSI (2007). Construction Specification Institute, [www.csinet.org/](http://www.csinet.org/).
- CURT (2007). The Construction User's Roundtable, [www.curt.org/](http://www.curt.org/).
- DBIA (2007). Design Build Institute of America, [www.dbia.org/index.html](http://www.dbia.org/index.html).
- Eurostep (2007). Information Solutions for a Global Age, [www.eurostep.com/](http://www.eurostep.com/). FIATECH (2010).
- The FIATECH Consortium, <http://fiatech.org>.
- GSA (2010). General Services Association, [www.gsa.gov](http://www.gsa.gov).
- IAI (2010). buildingSMART: International Alliance for Interoperability, [www.iai-international.org/index.html](http://www.iai-international.org/index.html).
- IFMA (2010). International Facility Management Association, [www.ifma.org/](http://www.ifma.org/).
- LCI (2004). Lean Construction Institute, [www.leanconstruction.org/](http://www.leanconstruction.org/).
- NIBS (2007). National Institute of Building Sciences, [www.nibs.org/](http://www.nibs.org/).
- OGC (2007). Geography Markup Language, [www.opengeospatial.org/standards/gml](http://www.opengeospatial.org/standards/gml).
- OSCRE (2010). Open Standards Consortium for Real Estate, [www.oscre.org/](http://www.oscre.org/).
- USGBC (2010). U.S. Green Building Council, [www.usgbc.org/](http://www.usgbc.org/).

## COMPANY AND SOFTWARE INDEX

Company	Products	Web Site	Page Reference
1stPricing	1stPricing Plug-Ins for AutoCAD® and TurboCAD	www.1stpricing.com	235
AceCAD	StruCAD®	www.acecad.co.uk	40, 269t, 270
ActiveFacility	ActiveFacility	www.activefacility.com	127
AEC Design Group	CADPIPE Electrical CADPIPE Hanger CADPIPE HVAC CADPIPE Industrial Commercial Pipe	www.cadpipe.com	43, 61, 269t, 276
ANSYS	Fluent CFX	www.fluent.com/ www.ansys.com/products/fluid- dynamics/cfx/	163t, 170t
aSa	aSa Rebar Software	www.asarebar.com	269t, 272
Autodesk®	Ecotect Design Review Navisworks Manage QTO Revit® Architecture Revit® Structure Revit® Systems3ds Max Autodesk Architecture	www.autodesk.com	29, 34t, 37, 43, 52, 54, 57–8, 60–61, 81, 120, 161, 163t, 164t, 169, 170t, 184, 184t, 186, 194t, 196, 218, 228, 229t, 235, 269t, 272, 276, 323t, 361t, 372, 379, 380t, 387, 452, 455, 458, 459, 461
AutoDesSys, Inc.	form Z Bonzai	www.formz.com	53, 64, 77, 158–9, 159f, 164, 164t, 204, 206, 323, 323t, 395–6, 408f
Beck Technology, Inc.	DProfiler with RSMeans	www.beck-technology.com	62, 100, 158, 165, 219, 324t, 442–7
Bentley Systems	Architecture Building Electrical Systems Building Mechanical Systems Facilities Planner Generative Components Microstation PlantSpace Design Series Structural Triforma STAAD Pro	www.bentley.com www.reiworld.com/	29, 34t, 37–8, 52, 54, 58–9, 61, 77, 81, 127, 163t, 169, 170t, 184t, 193, 229t, 231t, 269t, 276, 323t, 324t, 328t, 333, 333t, 357, 380, 381t, 382, 387, 395, 397–8, 404, 434
BIMWorld		www.bimworld.com	193, 195t, 196
BSD: Building Systems Design Inc.	Linkman-E speclink-e	www.bssoftlink.com/ linkman/linkman.htm	
Bluebeam	Bluebeam PDF Revu	www.bluebeam.com/web07/us/ products/revu/standard/	
Carrier	Carrier E20-II	www.commercial.carrier.com/com- mercial/hvac/general/0,,CL11_ DIV12_ET1495,00.html	170t, 184t

(continued)

Company	Products	Web Site	Page Reference
COADE Engineering Software	CADWorx® CEASAR II®	www.coade.com/	61
Common Point, Inc.	Common Point 4D ConstructSim OpSim	www.commonpointinc.com	129, 231–2
Computers and Structures Inc.	SAP, ETABS,	www.csiberkeley.com/	61, 372, 438
CSC	3d1	3dplus.cscworld.com/	269t, 270t
Dassault Systemes	CATIA	www.3ds.com/home/	54, 60, 323t, 413–4, 416
Data Design System UK Limited	DDS IFC Viewer	www.dds-bsp.co.uk/IFCViewer.html	79
U.S. Department of Energy	Energy Plus	www.eere.energy.gov/buildings/energyplus/	170t, 324t, 394, 394f, 395
Design Data	SDS/2	www.dsndata.com	29, 40, 269t, 270, 323t, 328t, 333t
Digital Building Solutions	BIMContent Manager	www.digitalbuilding solutions.com	195t
eRENA	ViCROWD	www.arena.kth.se	129t
Enterprixe	Model Server	www.enterprixe.com	127
EPM Technology	EDMserver	www.epmtech.jotne.com	127
Esteco	modeFRONTIER	www.esteco.com	180
Eurostep	ModelServer for IFC	www.eurostep.com	88, 127
Exactal Pty Ltd.	CostX™ CostX Viewer™	www.exactal.com	120–1, 122f
Flomerics	Flovent	www.flomerics.com/flovent/	170t
Flow Science	Micro Flow	www.flow3d.com	170t
FormFonts	Form Fonts 3D	www.formfonts.com	193, 195t
Gehry Technologies	Digital Project	www.gehrytechnologies.com	34t, 52–4, 60, 77, 127, 163, 177, 179t, 229t, 269t, 273, 407–13, 410f, 415–8, 420, 422–4, 427, 430, 467–8
Google	3D warehouse SketchUp	www.sketchup.com	19353, 58–9, 158, 160, 164t, 193, 194t, 195t, 219
Graphisoft <sup>1</sup>	ArchiCAD® ArchiGlazing, Ductwork ArchiFM	www.graphisoft.com	29, 59, 127, 218, 220, 229, 269t, 273, 276, 455
GT STRUDL	GTSTRUDL	www.gtstrudl.gatech.edu/	170t
IES	Simulex Apache	www.iesve.com	129t, 158, 162, 163t, 164t, 170t
IMSI/Design	TurboCAD	www.turbocad.com	235
Innovaya	Visual 4D Simulation Visual Estimating	www.innovaya.com	220–1, 231t, 292
Intellicad	IntelliCAD MEP	www.intellicad.org	323t, 328t, 333t



<b>Company</b>	<b>Products</b>	<b>Web Site</b>	<b>Page Reference</b>
Interspec	e-SPECS	www.e-specs.com	186
Leap Software	AXSYS PRESTO	www.leapsoft.com	434
Legion	Legion Studio	www.legion.com	1095, 129t
Lawrence Berkeley National Laboratory	DOE-2 Energy Plus Radiance	www.doe2.com/	170t, 324t, 394, 394f, 395
LKSoft	IDS_STEP Database	www.ida-step.net	88
MAP	CAD-Duct	www.cadduct.com	269t, 276,
Natural Works	Displacement Ventilation	ep.natural-works.com	392t, 393f, 394, 401–03f
Nemetschek	Allplan Engineering Allplan Building Services SCIA Engineer Vectorworks	www.nemetschek.com	xii, 259, 269t, 272–3
Newforma	Newforma Project Management Tool	www.newforma.com/	
Nomitech	CostOS v3.6 Estimating System	www.nomitech.eu.com	
Objects Online, Inc.		www.objectsonline.com	194t
Octaga	Modeler	www.octaga.com	79
ODEON Room Acoustics Software	ODEON	www.odeon.dk/	170
OnCenter	On Screen Takeoff®	www.oncenter.com	221
Onuma and Associates, Inc.	Onuma Planning System™	www.onuma.com	127, 323, 344, 356
Primavera Systems	P6	www.primavera.com	58, 138, 224, 229–32, 427
Progman	MagiCAD	www.progman.fi/en	
Quickpen	PipeDesigner 3D DuctDedesigner	www.quickpen.com	184, 269, 276
RAM International	Structural System Advanse Connection Concept	www.ramint.com/	58, 170, 324, 328, 333
Renkus-Heinx Inc.	EASE	www.renkus-heinz.com/ease/ease_ intro/intro_ about_ease.html	173t
Revit City	Downloads	www.revitcity.com	194t
Rhinoceros®	McNeel North America	www.rhino3d.com/	37, 53, 77, 159, 164t, 323t, 379, 380f, 385, 413–4
RISA Technologies	RISA 3D RISA Foundation RISA Floor RISA Tower	www.risatech.com/	58, 170t
Robobat	ROBOT Millenium	www.robobat.com	58, 170t, 324t, 413, 415f

(continued)

Company	Products	Web Site	Page Reference
Sage	Timberline Office	www.sagetimberlineoffice.com	220
SCADA Soft AG	WizCAD™	www.scada.ch	61
SoftTech	SoftTech V6 Manufacturer	www.softtechnz.com	269t, 273
Solar Energy Laboratory, U. Wisconsin	TRNSYS	http://sel.me.wisc.edu/trnsys	170
SMARTBIM	SMARTBIM Objects	www.smartbim.com/	
Solibri	Model Checker™	www.solibri.fi/	xiv, 79, 89, 122, 123f, 170t, 171, 218, 291, 296
SolidWorks Inc.	SolidWorks	www.solidworks.com/	54, 273, 323t, 413
SprinkCAD	SprinkCAD	www.sprinkcad.com	269t, 276, 323t, 361t
Strand7	STRAND	www.strand7.com	324t, 380, 381f, 413
StructureWorks	StructureWorks	www.structureworks.org	29, 54, 269t, 271
Synchro, Ltd.	Synchro 4D	www.synchro ltd.com	231t
Tectonic Network	BIM Library manager	www.tectonicnetwork.com	190, 196, 196f, 311
Tekla	Structures	www.tekla.com	29, 40, 40f, 52, 61–2, 81, 1707t, 181f, 184t, 204, 265f, 269t, 270, 271, 272, 273, 303, 323t, 383, 396–7, 397f, 432, 434f, 435, 438
TRANE	TRACE 700	http://www.trane.com/	
Trelligence	Affinity™	www.trelligence.com	158, 161, 164t, 171, 302
U.S. Cost	Success Estimator	www.uscost.com	120, 121, 220, 460, 461
Vela Systems	Vela Mobile™	www.velasystems.com	
Vico†	Constructor Takeoff Manager Estimator Office	www.vicosoftware.com	59, 220, 224, 229t, 231t, 298
Vizelia	FACILITY	www.vizelia.com	127, 129f
WolfRam research Inc.	Mathematica®	www.wolfram.com/	178, 180

<sup>||</sup>In March, 2007 Nemetschek, Inc. acquired Graphisoft. Throughout the book, however, all Graphisoft products are referred to as Graphisoft products.

<sup>†</sup>In June, 2007 Autodesk, Inc. announced its plans to acquire Navisworks. In the book, all Navisworks products are referred to as Navisworks products.

<sup>‡</sup>In March, 2007 Vico, Inc. was spun out from the Construction Solutions Division of Graphisoft.

# Index

---

## A

- Acoustic analysis, 226
- Acrobat (Adobe) 9 Pro Extended, 95
- AE BIM Manager, title, 355
- AGC BIM Guidelines for Contractors*, 278
- Aggregation, 57, 292
  - levels, 18
- Air flow simulations, 226
- AISC, 295–296
- Alquist Hospital Facilities' Seismic Safety Act of 1983, 432–433
- American Institute of Architects (AIA), 175
  - IPD guidelines publication, 357
- American Institute of Steel Construction (Steel Design Guide)*, 52–53
- American Society of Testing and Materials (ASTM) data, property set approximation, 58–59
- Analysis interfaces, integration (increase), 373–374
- Analysis/simulation applications, exchange capabilities, 227t
- Analysis/simulation software, 223–226
- Analysis types, integration (research), 378
- Analytic structural models, types, 104f
- ANSI-BOMA space area, derivation (example), 228f
- ANSYS CFS, usage, 551–552
- AP 225, 111
- AP 241, 111
- Application Program Interface (API), usage, 107
- Application Programming Interface (API), C# (usage), 405
- Applications, geometry exchanges, 101
- Application-to-application exchange, support, 101
- ArchiCAD, 68, 82–84, 374, 571
  - objects, display, 240f
  - parametric object support, 83
  - strengths/weaknesses, 84
- Architects
  - BIM adoption, 356
  - BIM usage, 193
- Architectural BIM design applications, 32
  - differences, 68–69
- Architectural design, construction (contrast), 194–195
- Architectural Desktop (ADT), 92–93
- Architectural drawings, orthographic projections (impact), 61
- Architectural Graphic Standards* (Ramsey/Sleeper), 54
- Architectural precast facade panels, design/detailing engineering (production lead time benchmark), 315f
- Architectural precast panel, parametric model, 52f
- Architectural services, 196
- Architecture, engineering, and construction (AEC), 17
  - activity, sectors (changes), 28
  - aecXML, 133
  - BIM, usage, 1
  - business model, 2–10
  - project team, conceptual diagram representation, 3f
  - revolution, 152–153
  - tools, 375
  - XML schemas, 133–134
- Architecture, engineering, and construction, facility management (AEC/FM), 9
- Architecture firms, workplace roles/activities (change), 366
- Army Corps of Engineers, 175
- Artificial intelligence, 381
- As-built changes, 6
- Assembly operations, development, 37
- Asset management tools, 170–172
  - usage, 168
- Assigned action items, 141
- Associated data/rules, 17
- Associated General Contractors (AGC)
  - agcXML, 133–134
  - BIM implications, 301
- Associated geometries, automatic modification, 17–18
- Association of General Contractors (AGC), 175
- Attribute handling, 58–60
- AutoCAD
  - ARCHITECTURE, 53
  - AutoCAD-based applications, 92–94
  - MEP, 53
  - strengths, 93
  - 3D, usage, 37
  - weaknesses, 93–94
- Autodesk Collaborative Project Management, 144
- Autodesk Design Review, 95
- Autodesk Ecotect, 373
- Autodesk Navisworks Manage software, 316
- Autodesk QTO, 278
- Autodesk Seek, 249
- AutoDesSys form Z, 79
- Automated clash detections, examples, 531f
- Automated code-checking, 386
- Automated design review software, development, 362–363
- Automated manufacturing technologies, usage (increase), 319, 321
- Automated model verification tools, 358–359
- Automated quantity takeoff, 534f
- Automatic partial updates, 141

- AutoView, 147
- Aviva Stadium
  - aluminum panel frames/brackets, fabrication, 410
  - architectural form, 399–400
  - case study, 397
  - cladding design/optimization, 408–409
  - cladding fabrication/erection, 409–412
  - cladding façade
    - components, design-to-manufacturing process, 411f
    - final assembly, 412f
  - collaboration, 403
  - concept development, 399–402
  - construction process, 407
  - criteria, 400
  - daylight studies, series, 400f
  - design requirements, 399–402
  - divide and conquer strategy, implementation, 408
  - envelope, setup, 404f
  - envelope detailing, 406–412
  - erection, 406–412
  - evaluation/lessons, 412–414
  - fabrication, 406–412
  - final onsite assembly, 411–412
  - hierarchical structural layout, diagram, 402f
  - horseshoe truss construction process, 407f
  - Louver opening layout, 409f
  - panel/brackets, detailing, 410f
  - panelization pattern/opening layout, 408
  - parametric approach, technical implementation, 403–405
  - parametric design/collaboration, 402–403
  - participant companies, 399t
  - project overview, 398–399
  - rigging table, sketch, 412f
  - Robot Millenium structural model, input loading data, 406f
  - roof fabrication, 406–408
  - roof horseshoe truss, release, 407–408
  - structural analysis/feedback, 405
  - structural layout, 401–402
  - views, 401f
- B**
- Barcode format, usage, 486f
- Barcode identities, 486–487
- Barriers technology, 188–189
- Bartender software, recordation, 486
- Base objects, usage, 47, 49
- Base parts, 55
- Beck Group, digital modeling effort, 558
- Behavior, support (absence), 19
- Bentley Generative Components (GC) software, 402
- Bentley ProjectWise
  - Collaboration System, snapshot, 461f
  - Integration Server, 144
  - online Model/Document Management/Collaboration System, usage, 458
  - system, usage, 459
- Bentley structures, 225
- Bentley Systems, 80–82
  - additions, 81
  - strengths/weaknesses, 82
- Bidirectional editing, top-level drawing functionality support, 63
- Big boxes, 200
- BIM Applications Support Engineer, title, 355
- BIM Specialist, title, 355
- BOCAD
  - fabrication, 406–407
  - macros, customization, 407
- Bonzai (FormZ), 67
- Bonzai3d, 205, 210–211
- Boolean operations
  - combination, 36
  - definition, 586
  - usage, 34f
- BootCamp (Windows), 77
- Boundary representation (B-rep), 585
- BPMN, 104
- B-reps, usage, 34f, 36
- Bridge projects, differences, 497
- Budget/actual cost, variances (tracking), 293
- Building
  - commissioning, efficiency, 168
  - components
    - expertise, embedding, 241–246
    - information, 269
    - computer modeling, concept, 354
    - construction, 100–101
      - ISO-STEP, usage, 111–113
    - core, layout (detail), 243f
    - design, 100–101
    - element, 3D CAD (usage), 41–42
    - future, BIM (usage), 29
    - hi-rise cores, set (sample), 242f
  - information
    - detail, 269
    - models, creation/sign-off, 161
  - infrastructure/environment, complexity, 160–161
  - modeler, 366
  - role, issue, 368
  - modeling
    - 3D solid modeling basis, 36–37
    - tools, functional difference, 49
  - object-based parametric modeling, 40–43
  - object models/libraries, 240–253
  - objects, definition, 18, 587
  - parametric modeling, 45–57
  - part information modeling applications, 321
  - performance/quality, increase, 21, 151
  - procurement, BIM (usage), 9–10
  - product manufacturers
    - 3D catalogs, 359
    - intelligent product specs, 385–386
  - subassemblies (fabrication), BIM (impact), 360
  - type, 559
- Building Automation and Control networks (BACnet), 106
- Building code requirements/regulations, conformance (analysis), 226, 228
- Building Data Model, definition, 586
- Building element models (BEMs), issues, 374–375
- Building Information Modeling (BIM)
  - activity, 353
  - adoption, 15
    - guidelines/issues, 189–191
  - approaches, inefficiencies, 10–15
  - architectural design applications, built-in base object families, 47t
  - architectural design tools, 46
  - asset management tools, usage, 168
  - associated processes, 20f
  - authoring tool, analysis application (interface), 224
  - benefits, 19–26, 396–397
  - BIM-based concept design, 204
  - BIM-based deliverables, 153f
  - BIM-based facility management products, usage/maturation (increase), 365
  - BIM-based planning, usage, 166
  - BIM-based scenario planning implementation, metrics, 580f
  - system, requirements, 577

- BIM-based takeoff, 280
- BIM Collaboration Format (BCF), 134
- BIM-enabled process change, 324–328
- BIM-integrated 4D Cad tools, commonness, 358
- BIM-related services, adaption/expansion, 361
- BIM-related skills/expertise, inclusion, 178
- BIM-specific prequalification criteria, inclusion, 178
- BIM-supported planning/scheduling issues/guidelines, 290–293
- CAD, contrast, 2
- challenges, 26–28
- change, obstacles, 382–385
- component definitions, relationship, 280f
- construction/fabrication benefits, 23–25
- database structure, 532f
- definition, 586
- development, 236, 353–354
  - societal/technical/economic drivers, 352
- drivers, 155
- economic drivers, 380–382
- effort, 187
  - participation, 190–191
- elements, libraries, 75
- energy efficiency/sustainability, improvement, 23
- environments, 32, 70–71, 76
  - definition, 586
- estimating tools, 170
- handbook instruction, 1
- impact, 380–389
- implementation, 302–303, 357
  - barriers, 185–189
  - issues, 27–28
  - process, post-tender stage, 534–537
- importance, 152–155
- import capabilities, 287, 290
- lean construction
  - relationship, 386–387
  - synergies, 297–300
- legal barriers, 187
- leveraging, 311–312
- modeling
  - applications, 94–95
  - technology, definition, 16
- NBIMS Initiative categorization, 16
- objects, built-in behaviors, 46–47
- onsite, use, 296–297
- owner demand, 354–355
- platforms, 56, 70–71, 77–94
  - default, 59
  - definition, 585
  - usage, 74–76
- post construction benefits, 25–26
- practice, changes, 27
- preliminary concept design, 214–215
- processes, 15–19, 356
  - definition, 586
- process flow, 271f
- quantity takeoff
  - estimating process, conceptual diagram, 279f
  - tools, usage, 164–165
- questions, 67–69
- repository, base requirements, 137
- risks, 185–189
- scope, 16
- service providers, network
  - construction/education, 179–180
- skills/employment, 388–389
- societal drivers, 380–382
- software, 276
  - suites, vendor construction, 373–374
  - tools, definition, 154
- space modeling, example, 159f
- standard efforts, 352
- system
  - definition, 586
  - usage, 28
- teams, measurement, 364
- technological capabilities, 363
- technological drivers, 380–382
- transition, 354
- trends, 354–361
- usage, 9–10, 26, 351, 369
  - owner demand, 351
- value, 268–269
- vendors, scope (expansion), 359
- Building Information Modeling (BIM)**
  - applications, 156t
  - definition, 585
  - distinction, 101
  - parametric tree representation, 38f
  - relationship, 173f, 182f
- Building Information Modeling (BIM)**
  - case studies, 29, 391
  - benefits checklist, 393t–394t
  - participant index, 393t
  - projects, description, 392t
  - software, checklist, 395t–396t
- Building Information Modeling (BIM)**
  - design
    - assessment, 157–160
    - benefits, 21–23
    - construction planning, synchronization, 24
    - disciplines, collaboration, 22
    - errors/omissions, preconstruction discovery, 24
    - intent
      - applications, 50
      - consistency, verification, 22
    - platforms, overview, 71–76
    - productivity benefits, 255–256
    - stage, cost estimates (extraction), 22–23
- Building Information Modeling (BIM)**
  - design applications, 44–45
  - adoption, 72
  - capability, 49–50
  - manufacturing-oriented
    - parametric modeling tools, differences, 69
  - set, development, 50–51
  - support, 38
- Building Information Modeling (BIM)**
  - (BIM) design tools, 31, 54, 72–74
  - complex curved surface modeling, 73
  - core, 49
  - custom parametric objects, development (ease), 73
  - extensibility, 75
  - interface, 74–75
  - interoperability, 75–76
  - multiuser environment, 76
  - properties management
    - support, 76
  - support, absence, 39
  - tool-level capabilities, 74
  - types, 57
  - user interface, 72–75
- Building Information Modeling (BIM)**
  - model
    - creation tools, 15–17
    - detail, 291
    - scope, 291
- Building Information Modeling (BIM)**
  - servers, 145
  - definition, 586
  - demand, increase, 374
  - functionality, 141–143
  - review, 144–148

- Building Information Modeling (BIM)
  - technology, 20f
  - definition, 15–16
  - development, 354
  - exploitation, 11
  - parameters, 19
  - trends, 356
  - usage, 264
- Building Information Modeling (BIM)
  - tools, 15–19, 70–71
  - construction management functions, integration, 359–360
  - definition, 586
  - development, 383–384
  - 4D capability, 286–290, 288t
  - impact, 373–376
  - problems, 43
- Building model
  - authoring tools, 375
  - definition, 587
  - geometric shapes, 336
  - information, richness/availability, 368
  - initial section, sketch, 62f
  - repositories, 100
    - definition, 587
    - evolution, 136–148
  - usage, example, 169f
- Building Object Model (BOM)
  - definition, 587
  - libraries, 60
  - portals, 249–252
  - product portals, comparison, 250t–251t
  - 2D/3D geometric representations, 247
- Building Process Modeling Notation (BPMN), 122, 124
- Building Services Life Cycle Analysis (BSLCA)
  - BSLCA-Integrated LCA tool, structure, 549f
  - software package, integration, 549–550
- buildingSMART
  - IFC, relationship, 113–114
  - International Implementation Support Group (ISG), 126
- Building system, 55
  - cost estimation, 229–230
  - design/analysis, 222–230
    - BIM, usage, 205–204
  - layout, 233–234
    - applications, 233t
    - simulation/checking, 222–230
- Built-in base object families, 47t
- Built-in structural analysis capabilities, 333–334
- Business goals, clarity/focus, 190
- Business practices, adoption, 12
- C**
- CADDUCT, 53
- CADPipe, 53, 102
- California State Senate Bill 1953, 433
- CAMduct, 102
- Campus-wide project, 4D
  - snapshots, 284f
- Capital Facilities Information Handover Guide, 175
- Cast-in-place (CIP) concrete, layout/framework detailing, 338
- Cast-in-place (CIP) reinforced concrete, 337–338
- Castro Valley Medical Center case study, 316
- Ceiling, clerestory wall, 43f
- Celestory wall, 43f
- Center for Integrated Facility Engineering (CIFE)
  - field productivity illustration, 10, 10f
  - Working Paper on Virtual Design and Construction, 190
- Change, drivers, 380–389
- Change Order (CO), 255
  - issuance, 6
- CIMsteel Integration Standard Version 2 (CIS/2), 100, 111, 295
  - definition, 587
- City Geography Markup Language (cityGML), 106
- CityGML, 134
- Clad Engineering, 409
- Clash detection
  - design/planning, 503–505
  - illustration, 537f
  - layout, combination, 555f
- Closeout maintenance, BIM
  - usage, 484
- Cloudworx, 421
- Code conformance/constructability,
  - automated checking (development), 352
- Collaboration
  - challenges, 26–27
  - improvement, IPD (usage), 21
- Colocation, 239
- Commitment tracking, 461
- Communication, two-way cycle, 307
- Company best practices,
  - incorporation, 55
- Company Way, 387
- Complex curved surface modeling, 73
- Component-based simulation, 363f
- Components
  - reorganization, 291
  - reporting, 329–330
  - temporary components, 292
  - virtual construction, 306
- Composite systems, 338, 339
- Computational Fluid Dynamics (CFD),
  - 46, 226
  - model, input, 378
  - simulation, 550–554
- Computer-aided design (CAD)
  - behavior, unlearning, 344–345
  - BIM, contrast, 2
  - CAD-based applications, drawback, 342
  - MEP/Revit, interoperability (absence), 457
  - public domain exchange format, 105
  - systems, 31
    - plotted drawing production, 15
  - technologies, production, 362
  - workstations, phase replacement, 346
- Computer-aided design and drafting (CADD), 195, 366
- Computer-controlled production
  - machinery, technical progress, 381
- Computerized Maintenance Management System (CMMS), 484
  - tool, 172
- Computer modeling, concept, 354
- Computer numerically controlled (CNC) machinery, 319, 321
  - instruction output, 334
- Computing power, technical progress, 381
- Concept design, 205
  - circulation analysis, abstraction, 219f
  - summary, 222
- Concepts, 124–126
  - example, 125f
- Conceptual design, 193–194
  - issues, 221–222
- Conceptual estimating workflow,
  - DProfiler (usage), 560f
- Concrete printing, 378
- Construction
  - activities, verification/guidance/tracking, 296–297
  - analysis/planning, 281–293
  - BIM design applications, differences, 68–69
  - BIM implementation, 357
  - BIM tools, predefined objects, 48t
  - clients, impact, 362–363

- companies
  - impact, 367–369
  - information integration, 387–388
- contracting, impact, 369–371
- design, integration, 254
- education, impact, 371
- estimated costs (labor cost), 11
- firms, types, 265–268
- 4D view, 283f
- hourly workers, real wages (trends), 13f
- labor productivity indexes, 10f
- management functions, BIM tools (integration), 359–360
- paperwork, reduction, 327
- parametric modeling, 50–54
- planning
  - 4D CAD requirements, 24
  - support, 4D models (usage), 283–284
- process, 237
  - visualization, BIM (usage), 299–300
- procurement/design, synchronization, 25
- productivity, decrease (reasons), 12–13
- products (visualization), BIM (usage), 299–300
- regulation, 386
- review, 196
- schedule, Gantt chart (sample), 282f
- workers, benefit packages, 12
- Construction detailing (CD), 196, 201
- Construction industry
  - analysts, process changes, 353
  - efficiency, construction cost (NIST study), 13–15
  - interoperability inadequacy, costs (addition), 14t
  - labor productivity, CIFE study, 10–13
- Construction-level building models, 230–236
  - building systems layout, 233–234
  - collaboration, 239
  - design review, 238–240
  - drawing/document production, 234–236
  - human interaction level, 239
  - integration, benefits, 237–238
  - specifications, 236
- Construction-level information, development, 204
- Construction-level model development, 230–231
- Construction-level modeling, 194
- Construction Management at Risk (CM at Risk), 4, 8
- Construction management (CM) information, 54
- Construction manager (CM) oversight, 187–188
- Construction Operations Building information exchange (COBie), 120–121, 131–132, 175
  - COBie2 data sections, 132
  - objectives, 131
  - updating, 131–132
- Construction sites
  - BIM, usage, 367–369
  - offices, BIM/4D CAD (usage), 369
  - work face, 378–379
- Construction Users Roundtable (CURT), 190
- Constructive Solid Geometry (CSG), 34–36
  - CSG-based CAD systems, 43
  - definition, 587
  - expressions, shape parameters, 36
  - operation/primitive shapes, 35f
- Contour crafting, 378
- Contractors
  - BIM adoption, 356
  - BIM coordination, usage, 364–365
  - BIM development processes, 270–272
  - BIM usage, 263
  - coordination/scheduling, Navisworks model, 429f
  - cost estimating, 275–281
  - designers, collaborations, 369–371
  - economic interests, 382
  - 4D, usage, 364–365
  - offsite components, usage, 10
  - quantity takeoff, 275–281
  - success, 5
- Contractors' Guide to Building Information Modeling*, 301–302
- Contracts
  - changes, implications, 300–302
  - deliverables, 183f
  - language, modification, 180–185
- Coordination/collaboration, communication (requirement), 195, 197
- CORENET, 228
- Core thermal zone modeling, example, 219f
- Cost estimates
  - obtaining, 152
  - reliability, impact, 162–163
- Cost estimating, 275–281
  - process, automation (upfront work), 472f
- Cost estimation, output (example), 221f
- Cost management, 162–165
  - BIM applications, usage, 163
- Cost reliability, 162–165
- Cost/schedule control, integration, 293–295
- Courthouse circulation path, access (security), 364f
- Courts Design Guide*, 218
- Courtyard by Marriott
  - air quality, 426
  - aspect models synchronization, 430
  - building process, sequence, 419f
  - case study, 415
  - contractors coordination/scheduling, Navisworks model, 429f
  - design approach, 418–419
  - design/evaluation interaction, 430
  - design workflow, 419f
  - energy model, 426–427
    - analysis results, 427f
  - façade design, 418
  - façade precast panels, 423–425
  - floor-by-floor modeling process, 421f
  - integrated 3D scan, 420f
  - LEED analysis results, 427–428
  - LEED certification, 425–426
  - LEED standards, achievement, 428f
  - LEED/Sustainability ROI analysis, costs, 428f
  - lessons, 430–431
  - main entrance visualization, 416f
  - multi-hotel model, Revit (usage), 416f
  - point grid correction, 422–423
  - point grid generation, 422f
  - precast façade panels installation, 424–425
  - precast panel installation
    - process, 425f
  - project goals, 417–418
  - project overview, 417t
  - reality layer, 424
  - resource efficiency, 418
  - scanning, 430
    - process, 420–421
  - sloping slab, slab edge detail, 424f
  - structure recycling, 417–418
  - structure scanning, 419–423
  - subcontractor coordination, 429–430
  - surface generation, 421–422
  - surface modeling, 421–422
  - sustainable design, 418
  - team coordination, 429–430

- Courtyard by Marriott (*Continued*)  
 3D solid model, 2D profiles, 423–424  
 urban impact, 417  
 water savings, 426
- Critical Path Method (CPM) scheduling software, 281
- Crown House Technologies, hospital project system, 322
- Crusell Bridge  
 BIM software provider, 498  
 bridge deck, architectural rendering, 495f  
 case study, 494  
 clash, example, 505f  
 clash detection, design/planning, 503–505  
 construction  
   phase, BIM usage, 502–512  
   planning, 4D (interaction), 505–507  
   stage, 497–498  
 cut section views, 504f  
 data, 496t  
 design, solicitation, 496  
 file transfer, information exchange, 500f  
 final product, initial model (preparation), 505  
 information exchange, synchronization (usage), 501f  
 in-house fabricator software, screenshots, 508f  
 interoperability, 498–500  
 laser scanning, 510–511  
 Last Planner System, BIM support, 511–512  
 learning experience, 497–498  
 lessons, 512–513  
 model synchronization, 500–502  
 point cloud, photograph/scan, 510f  
 project phases, BIM/applications (usage), 499t  
 project team, 496t  
 project timeline, 497f  
 rebar  
   detailing/fabrication/installation, 507–510  
   material takeoffs, Tekla Structures provision, 508–509  
   workflow, 509  
 rendering, 494f  
 schedule, 4D video animations, 505–506  
 structural steel  
   components, fabrication/installation, 507  
   onsite erection, 507  
   structure, building model, 495f  
   synchronization  
     performing, 501  
     requirement, 501–502  
   temporary structures, design/planning, 503–505  
   visualization, 503  
   work sections, 506f
- CSI Masterformat, 253
- Curtain walls, 338–339, 547f  
 importance, 339  
 modeling, 339  
 popularity, 547
- Curved surface modeling, complexity, 73
- Custom component libraries, preparation, 345
- Customizable parts/relationships, 328–329
- Custom numerical control (CNC) fabrication, support, 378
- Custom parametric objects, development (ease), 73
- Custom tags, defining, 135
- Cutting instructions, output, 334
- Cycle times, reduction, 314–315  
 BIM, usage, 298
- D**
- Data exchange, complexity, 110f
- Data eXchange Format (DXF), 108
- Data models, 99
- Daylight studies, series, 400f
- Decision-making, quality (empowerment), 205
- Decomposition, 292
- Deliverables  
 requirements, change, 180–185
- Deliverables, COBie specification, 131
- Delta BIM (ArchiCAD), 66
- DELTA-server technology, 374
- Design  
 alternatives (development/assessment), Onuma System (usage), 158f  
 BIM, impact, 193–194  
 construction  
   integration, 254  
   planning, synchronization, 24  
 coordination  
   conflicts, avoidance, 316–317  
   errors, reduction, 315–317  
 detailing/integration, collaborative process (BIM support), 307  
 disciplines, collaboration, 22  
 errors  
   preconstruction discovery, 24  
   reduction, clash detection (usage), 272–275  
 firms  
   change, 365–366  
   staffing, change, 258–260  
 intent, 199  
   consistency, 22  
 model  
   integrity, maintenance, 377  
   usage, 23  
 omissions, preconstruction discovery, 24  
 processes, BIM (usage), 203  
 procurement/construction synchronization, 25  
 professions  
   impact, 365–367  
   services, 384–385  
 scenarios, reconfiguration/exploration, 158, 160  
 team, collaboration, 231  
 technical services, range, 202  
 visualizations, 21
- Design-bid-build (DBB)  
 approach, 4–7, 10–11  
 process, requirements, 6  
 procurement process, 199  
 schematic diagram, 4f
- Design-build (DB)  
 construction projects, 381  
 contractor, contractual relationship (establishment), 8  
 delivery, modification, 184–185  
 owner/client, commercial relationship, 199–200  
 process, 4, 7–8  
 projects, LACCD BIM standard workflow/deliverables, 7f
- Design Build Institute of America (DBIA) estimates, 8
- Design changes  
 automatic low-level corrections, 21  
 reaction, 23–24
- Design-construction integration, 237–238
- Design development (DD), 196, 201  
 collaborative process, BIM support, 307
- Design-engineering-construction project-oriented market, 142
- Designers  
 contractors, collaborations, 369–371  
 cost estimation, importance, 229–230  
 economic interests, 382



- services/roles, shift, 365–367
- top-down design development approach, 319
- Design for fabrication, 204
- Design-for-manufacturing (DfM) rules, 46
- Designing (future), BIM (usage), 29
- Design practice
  - adoption, 253–258
  - BIM justification, 253–256
  - phased utilization, 257–258
  - training/deployment, 256–257
- Design services
  - changes, value added cost, 198f
  - compensation/distribution, 198f
  - concept design development, 254
  - providers, 309–310
  - scope, 197–203
  - specialization/commoditization, economic driver, 380
- Desktop/LAN libraries, 252–253
- Detailing
  - costs, reduction, 317–319
  - production phases, automation (increase), 366
- Detailing for Steel Construction* (AISC), 54
- Devenney, 447
- Dictionaries, international framework, 129–130
- Digital interoperability, resolution, 455
- Digital model, signing, 373
- Digital Project (DP) (Gehry Technology), 40, 68, 84–86, 522
- scalability, 85
- strengths/weaknesses, 86
- Direct links, API usage, 107
- Distributed computing, technical progress, 381
- Divide and conquer strategy, implementation, 408
- Documentation
  - production phases, automation (increase), 366
- Documentation ownership/production, legal changes, 27
- Document production, 234–236
- Document Type Declarations (DTDs), 135
- Domain Committees, 113
- DPR Construction, 465–467
- DPR model-based cost estimating solution, 468–469
- DProfiler, 91–92, 276, 373
- strengths/weaknesses, 92
- system, 229
- usage, 560f
- DPR self-perform work, 468f
- Drafting productivity (improvement), BIM systems (usage), 342–343
- Drawing eXchange Format (DXF), 99
- Drawing generation, 60–64, 73
  - plan/section/elevation, usage, 62
- Drawing production, 234–236
  - process, automation, 63–64
  - weak level, 62–63
- Drawings
  - importance, 372–373
  - production automation, 235–236
  - role, 384
- Drawing sheets, inclusion, 61
- Drilling instructions, output, 334
- Drofus, 145
- Duct sections, fabrication, 341
- DWF format, 102
- E**
- Early concept design
  - assessment, space names, 216–217
- Early concept design, BIM models, 215f
- Economic drivers, 380–382
- ElementWall, 117
- ELPOS, 338
- Employee-owner NURBS
  - geometric surface modeling tool, 207–208
- Energy analysis, 226
- Energy consumption (reduction), energy analysis (usage), 161–162
- Energy model analysis results, 427f
- Engineered to order (ETO) building components, annual market volume, 309t
- Engineered to order (ETO) components, 305, 308
  - fabrication, 370–371
  - fabricator product flow/information, 311f
  - prefabrication, 329
  - producers, 309
  - RFID tracking, 323
  - systems, types, 339
- Engineered to order (ETO) products, manufacturer application, 324
- Engineering
  - costs, reduction, 317–319
  - firms, workplace roles/activities (change), 366
  - productivity (improvement), BIM systems (usage), 342–343
  - services, integration, 194
  - staff, training, 344–345
- Engineers
  - BIM adoption, 356
  - BIM usage, 193
- Enterprise resource planning (ERP), 330
  - applications, usage, 388
  - systems, extensions, 388
- Envelope detailing, 406–412
- Envelope skin/structure, geometric definition, 404–405
- Environmental analysis tools, non-project-specific information, 213
- Environmental Sketch Suite, building model (analyses), 212t
- Equipment installation process, phases, 488
- Estimate accuracy, BIM quantity takeoff tools (usage), 164–165
- ETABS design analysis, 456
- EuroSTEP Share-A-Space Model Server, 146
- Evaluated shape, 36
- Exactal CostX Version 3.01, 278
- Exchange formats
  - definition, 587
  - proprietary exchange format, 107–108
  - schema, basis, 106f
  - types, 105–110
- Exchange Models (EMs), 124
- Exchanges
  - internal structure, support, 143f
  - process map, 123f
  - protocols, language support, 104
- Exchange schema, definition, 588
- EXPRESS, 104, 106
  - usage, 110–111
- Express elevators, 246f
- eXtensible Markup Language (XML), 104, 106
  - formats, 135
  - XML-based schemas, 132, 135
- External catalog files, links, 67
- External parameter management, 66–67
- External Reference Files (XREF), 93
- F**
- Fabricated components, design model (usage), 23
- Fabrication
  - BIM design applications, differences, 68–69
  - BIM tools, predefined objects, 48t
  - change, pace (planning), 345–347
  - components, reporting, 329–330
  - detailing, 306

- Fabrication (*Continued*)  
 human resources, considerations, 347  
 modeling, 53  
 operation, BIM adoption, 342–347  
   activities, 344–345  
   goals, setting, 343–344  
   tasks, automation, 333
- Fabrication-level BIM modeling  
 systems, 63
- Fabricators  
 BIM software, 334t–335t  
 BIM system requirements, 328–333  
 BIM usage, 305  
 classes, needs, 333–342  
 drawing sets, inconsistencies, 317  
 engineering department,  
   BIM workstations (staged  
   adoption), 346t  
 information visualization, 331, 333  
 in-house software, screenshots, 508f  
 interoperability, 351  
 software systems, 328–329  
 types, 308–310
- Facilities  
 assets management, BIM asset  
   management tools (usage), 168  
 information, commissioning/  
   handover (improvement), 25  
 maintenance  
   BIM usage, 484  
   optimization, 152  
 management database, 484–485  
 managers  
   BIM, usage, 151  
   building model, 172–175  
   operations, simulation, 160  
   organizational performance,  
   simulation, 230  
   retrofit/maintenance work, impact  
   (evaluation), 168
- Facilities management (FM),  
 167–169, 482  
 database, population, 168  
 optimization, 152  
 tools, 170–172
- Facilities management/operation  
 improvement, 25  
 product, 142  
 system, integration, 25–26
- Facility condition index, 569
- Facility Information Council (FIC), BIM  
 technology (definition), 15–16
- Feasibility studies, 196
- Feature, definition, 588
- Federated document collaboration  
 system, usage, 458–459
- Federated Model Management  
 architecture, 460f
- Feedback cycles, reduction, 403
- Fenestration, 338–339
- Field conditions (reaction), 4D-  
 coordinated BIM models  
 (usage), 166–167
- Field database access, 485–487
- Field personnel, PC usage, 332f
- Field scanning equipment tags, tablet  
 computer (usage), 488f
- File-based exchange, evolution, 136–148
- Financial risk, reduction, 151
- Finite element analysis, 333–334
- Finite element model (FEM), mesh  
 (representation), 103
- Form Fonts EdgeServer product, 249
- 4D CAD, 282  
 schedule analysis, 264  
 techniques, usage (examples), 331  
 usage, 369
- 4D-coordinated BIM models, usage,  
 166–167
- 4D financial model, 159f
- 4D model  
 benefits, 285–286  
 communication, 285  
 data interfaces, diagram, 289f  
 scaffolding, 292f  
 site logistics, 285  
 snapshot, 284f  
 stakeholder input, 285  
 views, 166f
- 4D modeling processes, 286–290  
 diagram, 289f  
 manual CAD-base methods, 286
- 4D scheduling software, support, 384
- Four-dimensional (4D) CAD,  
 requirements, 24
- Framework model, 114
- Freeform Concrete Construction  
 research project, 379f
- Freeform design, Bonzai (usage), 210f
- Freeform design, Rhino (usage), 208f
- Freeform façade, partial assembly, 40f
- Fully informed set, delivery, 447
- G**
- Gantt chart, sample, 282f
- Gases, supply/disposal (piping), 340
- Gehry Technologies (GT), 243
- General contractors, bids, 5
- General Motors Production Plant case  
 study, 314–315
- General Packet Radio Service (GPRS),  
 106–107
- General Service Administration  
 (GSA), 213  
 BIM model usage demand, 354–355  
 Preliminary Concept Design  
 Assessment Tool, general  
 configuration, 214f
- Generative Components  
 cladding, initial modeling, 408  
 usage, 39
- Geographical Information Systems  
 (GIS), 372
- Geometry  
 acquisition, laser scanning  
 (usage), 379  
 IFC representation, 118  
 Geometry Gym, 209
- Ghosting, 345
- Globalization, impact, 380
- Global positioning systems (GPS)  
 technologies, 297, 388
- Global Unique ID (GUID)  
 creation/reading, 140  
 object identification, 139
- Google 3D Warehouse, 249, 252
- Google Earth, 372, 572
- GoToMeeting, 440, 452  
 usage, 459f
- Graphisoft ArchiCAD, 40  
 BIM Server, 146
- Green building, demand (increase), 358
- Green Building XML (gbXML),  
 133, 372
- Green construction practices, 372
- Groupe Spécial Mobile (GSM), 106
- GT-STRUDL, 223
- Guaranteed Maximum Price (GMP), 8  
 construction manager, 481
- H**
- Hand-built models/datasets, 241
- Helsinki Music Center  
 advanced simulations, BIM  
 (usage), 546  
 applications/models, 545f  
 BIM development/application, 543  
 BIM flow/interoperability, 554–555  
 BIM tools, usage, 545–546  
 BSLCA-Integrated LCA tool,  
 structure, 549  
 case study, 539  
 clash detections, combined  
 model, 554  
 concert hall shell, computer building  
 model, 542f  
 curtain walls, 547f  
 popularity, 547

- design alternatives
    - comparison, energy simulation (usage), 546–549
    - comparison, LCA analysis, 551f
  - design quality/productivity (improvement), BIM (usage), 553–554
  - design team, BSLCA (usage), 550
  - energy consumption/cost comparison, 548f
  - glazing alternatives, simulation results, 548–549
  - Glazing Type One, 547
  - Glazing Type Two, 548
  - high-quality indoor environment design, CFD simulation, 550–554
  - hourly simulation, 548
  - HVAC/sprinkler network model, MagiCAD (usage), 554f
  - HVAC system design assessment, CFD usage, 552
  - IFC files, BPro COM-Server, 556f
  - layout/clash detection, model (combination), 555f
  - lessons, 555–556
  - lifecycle assessment (LCA), 549–550
  - lobby area
    - air temperature distribution, 552f
    - air velocity distribution, 553f
  - MagiCAD, usage, 553
  - model-based analysis, 544–545
  - musical instrument, tuning, 542
  - one-tenth scale model, 541f
  - project design, competition, 541
  - project team, 543–545
    - list, 543t
  - rendering, 540f
  - schematic design energy consumption
    - simulation results, 547f
  - schematic design stage, energy simulation, 546
  - working process, efficacy/competency (architect focus), 544
  - Hierarchical relations, 64–65
  - Hierarchical structural layout, diagram, 402f
  - High-quality indoor environmental design, CFD simulation, 550–554
  - Hillwood Commercial Project
    - benefits, realization, 564–565
    - BIM estimating process, overview, 559–562
    - Building Type, 559
  - case study, 557
  - conceptual estimating process, 558
    - support, BIM technology (overview), 559
    - workflow, DProfiler (usage), 560f
  - cost estimate
    - accuracy, 564
    - DProfiler snapshot, 562f
    - visual representation, 564–565
  - design alternatives, 562–564
  - design option, 562
  - details, overview, 558f
  - exterior window wall system, glazing frit film (usage), 562–563
  - information, DProfiler snapshot, 561f
  - labor-hours, estimation, 564
  - model, snapshot, 563f
  - preconstruction, reduction, 564
  - 3D site rendering, 557
  - 2D spatial view, DProfiler system screenshot, 563f
  - Horizontal Glue, 146–147
  - HVAC systems, ducts, 339
- I**
- IES VE, plug-in, 207
  - IfcElement, relationship, 117
  - IfcObject level, usage, 117
  - IfcRoot, assignment, 116–117
  - i-Model, 144
  - Independent quantity survey, 5
  - Industry Alliance for Interoperability (IAI), 113
  - Industry Foundation Class (IFC), 18, 106
    - building product data model, 99–100
    - buildingSMART, relationship, 113–114
    - coverage, 118–119
    - data format, usage, 216
    - defining, 114–117
    - definition, 588
    - export/import, user interface buttons, 120
    - files, BPro COM-Server, 556f
    - ifcXML, 135
    - interfaces, 209–210
    - interoperability, implications, 128–129
    - project, domain uses, 115f
    - Solutions Factory, 127
    - standardization, support, 129–135
    - structure, 116f
    - subschemas, system architecture, 115f
    - usage, 119–128
  - Inflation-adjusted wages, 12
  - Information
    - asset management, 167–169
    - contractors, BIM (usage), 268–270
    - development, concept, 200–203
    - exchange, interoperability (relationship), 522–523
    - exchange technologies, technical progress, 381
    - increase, 373–376
    - integration, 387–388
    - standardization, driver, 381
    - usage, 27
    - visualization, 331, 333
  - Information Delivery Manual (IDM), 124, 126
  - Information technology (IT)
    - reevaluation, BIM support, 17
  - Infrastructure coordination, integrated 3D MEP models (usage), 160–161
  - Initial Graphic Exchange Specification (IGES), 99
  - Innovator phase, 185–186
  - Innovaya, 277–278
  - Input room information, OPS
    - interfaces, 573f
  - Institute for Advanced Building Informatics (IABI), 126
  - Integrated Agreement for Lean Project Delivery (IFOA), 154
  - Integrated conceptual design
    - single model, multiple assessments, 217–221
  - Integrated conceptual design, example, 213–222
  - Integrated design-build services/agreements, 385
  - Integrated education, 371
  - Integrated Form of Agreement (IFOA), 357
  - Integrated practice, benefits, 357
  - Integrated Project Delivery (IPD), 9
    - approach, 153–154
    - arrangements, 369
    - guidelines, AIA publication, 357
    - option, 200
    - owner (primary beneficiary), 9
  - Integrated project team,
    - development, 436f
  - Integration, increase, 373–376
  - Interaction information
    - workspaces, 358
  - Internal leadership/knowledge, building, 176–177

- International Construction Information Society (ICIS), OmniClass development, 130
  - International Implementation Support Group (ISG), 126
  - International Organization for Standardization (ISO)
    - ISO 15926, 112
    - OmniClass development, 130
  - International Standards Organization-Standard for the Technical Exchange of Product (ISO-STEP) model data, definition, 588
  - Internet, impact, 376
  - Interoperability, 99, 331
    - definition, 588
    - importance, 105–106
    - information exchange, relationship, 522–523
    - model information, mapping, 104–105
    - tools, technical barrier, 382–383
  - ISC Project, planning system (usage), 574–576
  - ISO-STEP, EXPRESS (usage), 110, 114
  - ISO-STEP-based formats, 108
  - ISO-STEP-development data modeling language, 106
- J**
- Job skill requirements
    - examples, 179
    - modification, 178
  - Jotne EDM Model Server, 147
- K**
- KanBIM systems, 369
  - KanBIM user interface, example, 370f
  - Keogh McConnell Spence (KMCS), 398
  - Knowledge embedding tool, 56–57
- L**
- Labor productivity, indexes, 10f
  - LADAR, usage, 323, 388
  - LANDCADD, 79
  - Lansdowne Road Stadium Development Company (LRSDC), 398
  - Laser scanning
    - point cloud data, mapping, 360f
    - usage, trend, 379
  - Laser scanning technologies, 296–297
  - Last Planner System (LPS)
    - BIM support, 511–512
    - meetings, 505–506
  - Last responsible moment (LRM), 450
    - milestones, 447
  - Leadership in Energy and Environmental Design (LEED)
    - analysis results, 427–428
    - certification
      - requirements, conformance, 366
      - schemes, 372
    - compliance, 358, 385
    - evaluation, feature (addition), 294
    - Gold certification, 415–416, 427
    - standards, achievement, 428f
    - Sustainability ROI analysis, costs, 428f
  - Lean construction
    - BIM, relationship, 386–387
    - BIM, synergies, 297–300
    - techniques, 24–25
  - Leaner construction, 325–326
    - processes, BIM facilitation, 326
  - Lean principles, 299t
    - BIM support, 300
  - Learning curve, difficulty, 186–187
  - Legion Studio, visual/analytical outputs (examples), 167f
  - Leica Geosystems HDS Worldwide User Conference, 423
  - Letterman Digital Arts Center (LDAC), model completion, 296
  - Letterman Lucas Digital Arts center team, model usage, 172
  - Level of detail (LOD), 291
    - issuance, 234
  - Lifecycle assessment (LCA), 549
  - Lifecycle maintenance, 322–324
  - Lighting simulation, 226
  - Limited Liability Corporations (LCCs), 357
  - Line-by-line layout, change, 195
  - Liquids, supply/disposal (piping), 340
  - Lite BIM tools, 383
  - Local area network (LAN)
    - environments, usage, 439–440
  - Long transactions, 138
  - Look-ahead network plan, 462f
  - Los Angeles Community College District (LACCD), 176
    - BIM DB project standard, 7f
    - BIM usage guidelines, 8
  - Louver opening layout, 409f
  - Low-cost CAVEs, 384
- M**
- Machine-guidance technologies, 297
  - Made-to-order components, 308
  - Made-to-order plant-management market, 142
  - Made-to-stock components, 308
  - MagiCAD, usage, 554f
  - Maintenance work orders, usage, 490–491
  - Management functions, 293–295
  - Management information systems, interface, 330–331
  - Manual CAD-based methods, 286
  - Manufacturers, long-term agreements, 12–13
  - Manufacturing hourly workers, real wages (trends), 13f
  - Manufacturing-oriented parametric modeling tools, BIM design applications (differences), 69
  - Maryland General Hospital (MGH)
    - barcode format, usage, 486f
    - BIM usage, 487f
  - Building Information Systems, 483–487
    - case study, 323–324, 480
    - closeout, BIM usage (reasons), 481–483
    - closeout maintenance, BIM usage, 484
    - construction/closeout/ commissioning, 487–489
  - equipment
    - addition/replacement, 489–490
    - addition/replacement processes, 490f
    - data, Tekla software (custom tabs), 489f
    - equipment installation process, phases, 488
  - facility maintenance
    - BIM usage, 484
    - workflows, 489–491
  - facility management
    - BIM integration, 487f
    - BIM usage, 481–482
    - database, 484–485
  - field database access, 485–487
  - field scanning equipment tags, table computer (usage), 488f
  - Guaranteed Maximum Price (GMP)
    - construction manager, 481
  - lessons, 492–493
  - maintenance work orders, 490–491
    - processes, 491f
  - MEP systems, modeling, 483
  - process, shortcomings, 482
  - rendering, 481f
  - service calls, 491
  - Masonry, parametric model, 56f
  - Mass customization, 307
  - Massing studies, generation, 216f

- Mass objects, 211
- Masterformat, 130
- Material takeoffs, generation, 313–314
- Mechanical, electrical, and plumbing (MEP) systems, 305
  - model view, 340f
  - requirement, 235–234
  - usage, 61
- Mechanical parts (generation), B-reps/  
Boolean operations (usage), 34f
- Mega-panels, 518
  - shop drawing, 524f
  - structural analysis, Robot (usage), 523f
  - support, 519
- Memory-based systems, 65
- Memory-swapping, occurrence, 65
- Merck Research Laboratories,
  - auditorium (layout detail), 235f
- Metadata, 119, 330
  - term, coinage, 139
- Microstation CAD files, usage, 404
- Mission dependency index, 569
- Mobile computing, power (increase), 382
- Model analysis, 376–379
- Model-based cost estimating, 462–475
  - benefits, 473–474
  - lessons, 474–475
  - options, DPR identification, 466–467
  - process, 466f, 469f
- Model-based estimating, nonintegration, 467
- Model geometry, requirement, 377–378
- Model information
  - organization, 181, 183
  - scope/detail, 181
  - uses, 181
- Modeling applications, 94–95
- Model manager, 260, 366
  - role, 385
- Model ownership/management, issues, 187–188
- Model synchronization, definition, 588
- Model View Definition (MVD), 120
  - preparation, 358
  - uses, 128–129
- Model viewer software, 374
- Model views, importance, 120–122
- Model View Validation, 126
- Modified design-build delivery, 184–185
- Module pattern, 246f
- Moore's Law, 382–383
- Multicriteria optimization methods,
  - availability, 378
- Multidisplay environments, 358
- Multidisplay workspace, 359f
- Multi-home model, Revit (usage), 416f
- Multiple BEM platforms, 374–375
- N**
- National 3D/4D BIM Program,
  - establishment, 180
- National Building Information Modeling Standard (NBIMS), 122, 181, 295–296
  - Committee of the National Institute of Building Sciences (NIBS), BIM technology definition, 15–16
  - construct phase (phase three), 126–127
  - defining/implementing, steps, 121f
  - deploy phase (phase four), 127
  - design phase (phase two), 124–126
  - Initiative, BIM categorization, 16
  - methodologies, 17
  - phases, 122–127
  - program phase (phase one), 122, 124
  - tools, commonness, 352
  - usage, 100
- National Institute of Building Science (NIBS), 120
- National Institute of Standards and Technology (NIST)
  - construction industry inefficiency cost study, 13–15
- National Institute of Standards and Technology (NIST), information flow/redundancy study, 10
- Navigant, 447
- Navisworks, 239
  - model, 429f
    - combination, 458f
- Neutral format building models, 228
- Nondomain specific/extensible schema, 94
- Nonfarm industries, labor productivity indexes, 10f
- Nonmodified objects, elimination, 66
- Nonuniform B-splines (NURBS), 38
  - surfaces, 118
  - surfaces, limitation, 206
- O**
- Object-based parametric modeling
  - definition, 589
  - evolution, 32–45
  - strengths/limitations, 67–68
- Object libraries, 246–249
  - organization/access, 248–249
- Objects
  - class, definition, 588
  - definitions, 247–248
- feasibility, violation, 18
- grouping, requirements, 340–341
- management, links, 65–66
- metadata, synchronization, 140t
- model, support, 99
- parameters, cost assemblies (matching), 472f
- Off-Cycle Crew Support Units (OCCSU), 568t
  - benefits, 583
  - lessons, 582–583
  - Planner system, workflow, 578f
  - system, 581–584
    - implementation, 582
    - requirements, 581–582
- Office of Statewide Health Planning and Development (OSHPD), 431–432
  - phased plan review process, 442
- Offsite fabrication, planning/design information, 295–296
- OmniClass, 130
- On-demand drawings, 372–373
- 100 11th Avenue (New York City)
  - BIM skill set, requirement, 525
  - case study, 514
  - condominium project, 514f
  - cross-section view, 521f
  - curtain wall assembly, 518–519
  - drawings, FormZ model, 517f
  - fabrication activities, 519–520
  - fabrication team, 519
  - glass pane variation, master spreadsheet (usage), 517f
  - information exchange, interoperability (relationship), 522–523
  - innovation/challenges, BIM process, 516–521
  - lessons, 523–525
  - material selection, 516
  - mega-panel
    - assembly, 516, 518
    - parametric Powercopy, 518f
    - shop drawing, 524f
    - structural analysis, Robot (usage), 523f
  - parametric modeling, 516–519
  - parametric panels, 516
  - performance mock-up, 520–521
  - project team, 515t
  - slab edge detail, 521f
  - sound transmission class (STC), prescription, 515
  - visual mock-up, 519–520
  - photo, 520f

- One Island East (OIE) Office Tower, case study, 177, 181, 185, 276–277
- One Island East (OIE) Project, Hong Kong  
 automated clash detections, examples, 531f  
 automated quantity takeoff, 534f  
 BIM creation/coordination, 529–530  
 building information model creation/coordination, 529–530  
 database structure, 532f  
 data structure, 533f  
 elements, usage, 535–536  
 implementation process, post-tender stage, 534–537  
 organization/structure, 531–533  
 structure, 532–533  
 case study, 526  
 clash detection, illustration, 537f  
 computer rendering, 528f  
 construction sequence, illustration, 536f  
 developer, Swire Properties, 527–528  
 information, summary, 527t  
 lessons, 537–539  
 Podium, BIM data structure, 533f  
 pretender stage BIM implementation stage, 528–534  
 product structure, 531–532  
 project elements, three-dimensional coordination, 537f–538f  
 project organizations, 528–529  
 project team, BIM integration, 529f  
 schedule integration/visualization, 536f  
 site progress, 535f  
 tendering, 533–534  
 2D/3D translation, 530f
- Online access/review, initiation, 371–372
- ONUMA Planning System (OPS), 571  
 input room information, interfaces, 573f
- Onuma System (OS), usage, 158f
- OpenBIM Collaboration Format, 275
- Open Geospatial Consortium (OGC), 175
- OpenGIS (XML schema), 133
- Open Standards Consortium for Real Estate (OSCRE), 174–175
- Operating room, component-based simulation, 363f
- Operational productivity, improvement, 162
- Operation simulation tools, 172
- Operations & maintenance (O&M), 131  
 square footage, 14
- Oracle Primavera, 147
- Organizational boundaries, 3f
- Organizational changes, implications, 300–302
- Output only third-party plug-ins, 374
- Outsourcing, impact, 185
- Owners  
 BIM adoption, guidelines/issues, 189–191  
 BIM application areas, 155–168  
 BIM example, 174t  
 BIM tool guide, 169–172  
 BIM usage, 151  
 building model, 172–175  
 impact, 361–365  
 postconstruction, 365  
 preconstruction benefits, 20–21  
 upper/lower limits addition, 163f
- P**
- Paper-based practices, 20
- Paper-centric processes, task automation, 17
- Paper drawings, usage, 380
- Parameter lists, external spreadsheets (usage), 66–67
- Parameter setting, input panel, 245f
- Parametric 3D model, insertion, 232
- Parametric 3D modeling, development, 354
- Parametric approach, technical implementation, 403–405
- Parametric assemblies, development, 242
- Parametric collaboration, 402–403
- Parametric Cost Engineering System (PACES) (EarthTech), 220
- Parametric design, 46–50, 402–403
- Parametric graph, rules (range), 38
- Parametric modelers, model exchange problems, 68
- Parametric modeling, 31, 45–57  
 degrees, 44–45  
 evolution, 37  
 example, 44f  
 importance, 50  
 systems, 45
- Parametric model platform, 139
- Parametric models, usage, 165
- Parametric object  
 capability, existence (absence), 55  
 customization, development (ease), 73  
 definition, 17–18, 589  
 provision, 39
- families, definition, 38  
 modeling, usage, 39
- Parametric parts/relationships, 328–329
- Parametric shapes, 57–69
- Parametric Technologies Corporation (PTC), 40–41
- Parametric Technology Corporation (PTC), 558
- Parametric tree representation, 38f
- Parametric wall, definition, 42–43
- Parts, configuration, 54–55
- Pass-through lobbies, 246f
- PCI Design Handbook* (Prestressed Concrete Institute), 52–54
- Peer object relations, 64
- Performance-based acquisition (PBA), 184
- Performance-based contracts, 184
- Performance-based design contracts, commonness, 385
- PERI CAD, 358
- Perimeter modeling, example, 219f
- Peripheral hardware, technology developments, 360
- Person-to-person collaboration, requirement, 139
- Phased utilization, 257–258
- Physical clash detection, 340–341
- Physical products, 2D/3D geometric representations, 247
- Pinned connections, fixed connections (differences), 224
- Piping spools, 341
- Planning matrix, solver generation, 246f
- Platform-to-tool data exchange, complexity, 102
- Platform-to-tool exchange, basis, 101
- Platform user interface consistency, 75
- PlumbingWall, 117
- Podium, 532  
 BIM data structure, 533f
- Point cloud surveys, production, 360–361
- Point grid correction, 422–423
- Polyhedral forms, composition, 33
- Post construction benefits, 25–26
- Powercopy, 518
- Preassembly  
 degrees, increase, 326  
 increase, 321
- Precast concrete, 335–336  
 automated reinforcing layout/connections (Tekla Structures), 51f  
 beam, drawings, 317  
 fabrication, needs, 335–336

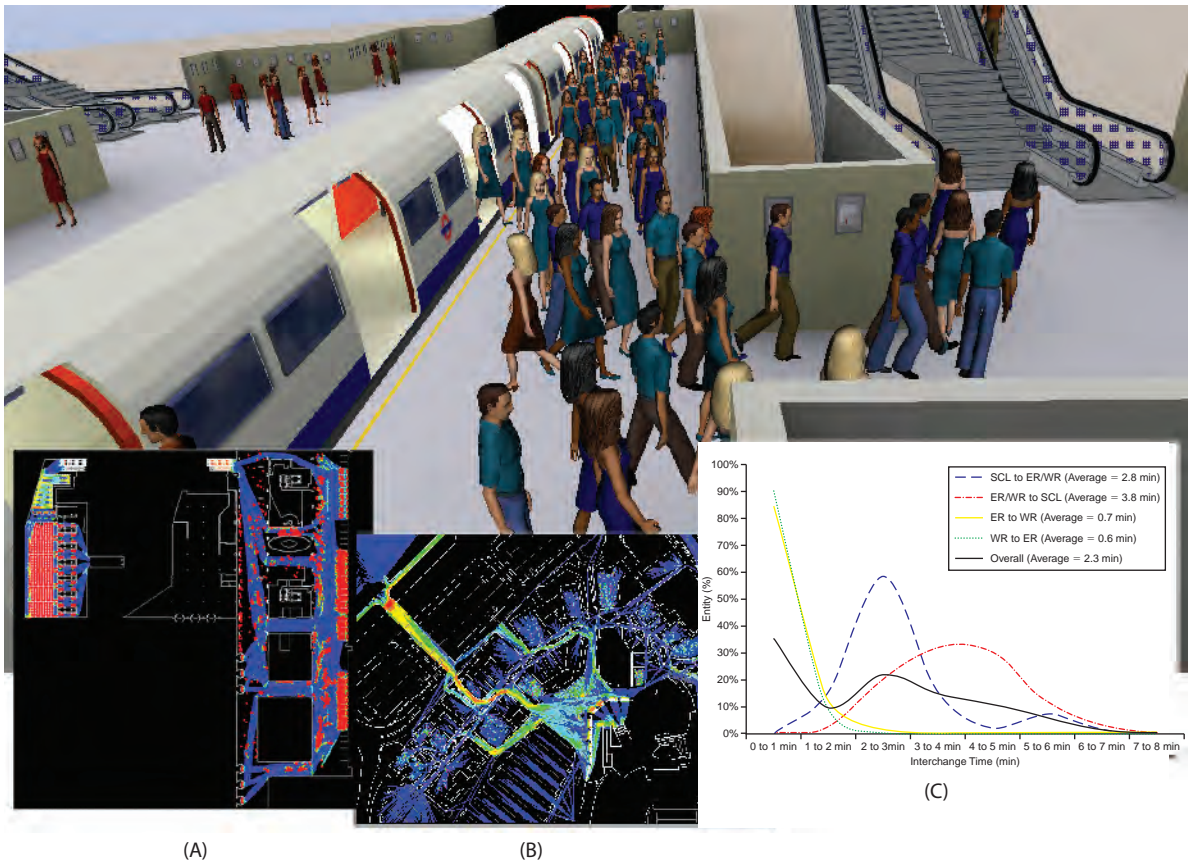
- spandrel beam, drawing
  - inconsistency, 318f
- Precast fabrication-level architectural façade, 51–52
- Precast façade panels installation, 424–425
- Precast panel installation process, 425f
- Precast parts, grouping, 336
- Preconstruction benefits, 20–21
- Predesign, 196
- Prefabricated ceiling services
  - modules, 323f
- Prefabricated ETO components, requirements, 330
- Prefabricated solutions, viability, 314
- Prefabrication
  - degrees, increase, 326
  - increase, 321–322
  - trend, 322
- Preliminary circulation/security
  - assessment, 218
- Preliminary cost estimate, 220–221
- Preliminary energy analysis, 219–220
- Pretender stage BIM implementation
  - process, 528–534
- Primitive shapes, 34
  - definitions/compositions, 35f
- Process barriers, 185–188
- Process Map, 122
- Process mapping, 461
  - network, 462f
- Procurement, purchasing/tracking, 294
- Product
  - exchanges, support, 99
  - data models, 110
  - life cycle time, reduction, 326
  - structure, 531
- Production
  - building code checkers, development, 377
  - cycle times, reduction, 313–315
  - detailing systems, vendors, 387–388
  - lead time, benchmark, 315f
- Product Lifecycle Management (PLM)
  - systems market, 142
- Program compliance
  - assurance, 152
  - checking, automated model
    - verification tools (usage), 358–359
  - improvement, 157–158
- Programmatic requirements, development (integration), 157
- Progress assessment, metrics
  - establishment, 190
- Project
  - axonometric views, 320f
  - BIM guidelines, development, 176
  - BIM implementation, leading, 175–185
  - collaborative single unit
    - contracting, 200
  - construction schedule, Gantt chart (sample), 282f
  - delivery, collaborative forms, 198–200
  - design
    - completion, 186
    - skills, demand (shift), 259t
  - documentation, impact, 372–373
  - elements, three-dimensional
    - coordination, 537f–538f
  - financing, 186
  - ghosting, 345
  - information, embedded views, 94–95
  - lifecycle, project cost (impact), 164f
  - management techniques, description, 434–442
  - phases, 362
    - illustration, 392f
  - processes, task automation, 17
  - process flow, 271f
  - representations, management, 103
  - return on investment (ROI), 165
  - risk, management, 154
  - schedule, reduction, 151
  - stakeholders, input (receiving), 158
  - status, 293
  - team collaboration, support, 18
  - transactions/synchronization, 136–141
- Project (Microsoft), 281
- Project data management (PDM)
  - systems, 136
- ProjectWise Navigator, 144–145
- ProjectWise system, 439–440
- Properties
  - handling, 58–60
    - long-term solution, 60
  - management support, 76
  - stages, 58
- Property sets (P-sets), 118–119
- Proprietary exchange format, 107–108
- Proxy objects, 211
- PSetWallCommon, 117
- Public product data model exchange
  - formats, 108
- Pull flow control, 325
- Pull production system, enabling, 313–314
- Purpose-built applications, maturation, 387–388
- Q**
  - Quality control, 325–325
- Quantity takeoff (QTO), 102, 275–281
  - estimating, support, 279–281
  - support, guidelines/BIM
    - implementation issues, 279–281
  - tool, 278–279
- R**
  - Radio Frequency Identification (RFID)
    - tagging, 361
    - tags, 297, 388
    - usage, 323, 341
    - technology, 360
      - feasibility, 330–331
  - Real wages, trends, 13f
  - Rebar
    - shapes, output, 336
    - workflow, 509
  - Reconstruction work, 12
  - Reinforced concrete building projects,
    - experimental data, 320t
  - Relational structures, 57–58
  - Relations
    - information, types, 58
    - object linkage, 118
  - Remote sensing technologies, technical
    - progress, 381
  - Request for Information (RFI), 255
    - involvement, 6
    - number, impact, 364
  - Research
    - impact, 376–379
    - requirement, 377–378
  - Revit, 68, 77–80, 209
    - architecture, support, 79
    - CAD MEP models, interoperability (absence), 457
    - MEP, 78
    - product libraries, 78
    - strengths, 79–80
    - structures, 78, 225
    - Tekla model, interoperability (absence), 457
    - weaknesses, 80
  - Rhino, 67
  - Rhinoceros (McNeel), 79, 205, 207–209
  - Rigging table, sketch, 412f
  - Robot Millenium structural model,
    - input loading data, 406f
  - RSMean cost data, 559
  - RUCAPS, 36–37
- S**
  - Safety management, 294–295
  - Sage Timberline, 277–278

- Scaffolding, 292f
- Scalability, 64–65, 74
  - definition, 589
- Scenario planning, BIM (usage), 577–581
- Schedule
  - duration (reduction), 3D
    - coordination/prefabrication (usage), 165
  - management, 165–167
  - properties, 292–293
- Schedule-related risk (reduction), BIM-based planning (usage), 166
- Schema, definition, 589
- Schematic design (SD), 196
- SDS/2 (Design Data), 51, 102
- Sector Command Center Planning (SCCP) Tool, 581
- SEEK (object library), 80
- Self-perform work, DPR model-based
  - cost estimating solution, 468–469
- Semantic searches, customization (development), 375
- Semantic searching, 374–375
- Sensor/control monitoring, 171
- Servers, cloud configurations, 138
- Service provider
  - impact, 173–174
  - interview, 178–179
  - network construction/education, 179–180
  - selection, 177–179
- Shapes, generation, 33f
- Shared incentive plans, 184
- Shop drawings
  - generation, 313–314
  - production, 314–315
- Shore Facility Capital Asset Management (SFCAM) Roadmap, 567
- Signing, notion, 373
- Simulation, 376–379
- Single-discipline design, 188–189
- Single-stage drawing-based deliverables, 153f
- Sketching
  - BIM applications, usage, 211
  - function-specific applications, usage, 212–213
- SketchUp (Google), 19, 67, 79, 205–209
  - capability, 206
  - layout, 207f
  - System Development Kit (SDK), 206
- SketchUp Pro (Google), 2D drawing generation, 206–207
- Skills, demand, 355
- Skinning, 211
- SmartBIM Library (SBL), 252–253, 359
  - multilevel structure, 252f
- Smart owners, demands, 363–364
- SMOG (space modeling package), 550
- Societal drivers, 380–382
- Software
  - customization, 345
  - estimation
    - BIM components, linkage, 277–278
    - quantity data, exportation, 277
  - package, acquisition, 77
  - wizards, 369
- Software tools
  - mixture/usage, 108–109
  - support, 205–206
- Solibri Model Checker and Issue Locator, 275
- Solid modeling, 33
  - CAD systems, power, 37
  - definition, 589
  - forms, 33–34
- Solutions Production Manager (SPS), usage, 461
- Space names, mapping relation, 217f
- Space object support, 171
- Space program validation, 217–218
  - reports, 218f
- Space utilization index, 569
- Spatial union, operations, 34
- Specialist coordinators, 310
- Specialization, increase, 373–376
- Specialized structural analyses, 336
- Splines, usage, 38
- Spreadsheet-based solver, development, 244
- Standardization, support, 129–135
- Statutory authorities, impact, 371–372
- Steel connections, automated/customizable detailing, 333
- Stick systems, 338
- Strategic project solutions production manager, usage, 461
- Streamline, 95
- StruCad (AceCad), 51, 102
- Structural steel, 333–334
  - connection (Tekla Structures), 329f
- Structured design, Bonzai (usage), 210f
- Structured design, Rhino (usage), 208f
- Structured Query Language (SQL), 105–106
- Stud layouts, assignation, 42
- Subcontractor fabricators
  - BIM process benefits, 310–324
  - marketing/tendering, 312–313
- Subcontractors
  - BIM software, 334t–335t
  - BIM usage, 305
  - types, 308–310
- Supply chain management, 322–324
- SureTrak (Primavera), 281
- Surface finishes/treatments, 336
- Sustainability, 161–162
  - impact, 380–381
- Sustainable construction practices, 372
- Sutter Health, Integrated Form of Agreement (IFOA), 357
- Sutter Medical Center, Castro Valley (SMCCV)
  - Autodesk Navisworks model/site, 458f
  - baseline schedule, 443f
  - Bentley ProjectWise Collaboration System, snapshot, 461f
  - BIM, usage, 456f
  - BIM planning, extent, 449f
  - biweekly meetings format, 451
  - case study, 431
  - commitment tracking, strategic
    - project solutions production manager (usage), 461
  - committed cost, graph, 471f
  - computer-generated image, 432f
  - construction approaches, 437t
  - contract method, 434–441
  - cost estimating process, automation (upfront work), 472f
  - costs, cluster, 470–471
  - design/construction alternatives, cost comparison, 474f
  - design/construction problems, list, 463t–464t
  - design plan, BIM fit, 449
  - design planning strategies, 447
  - design process
    - mapping, 445f, 448f
    - rework risk, elimination, 445–446
  - design team/builders, collaboration, 469–473
  - digital interoperability, resolution, 455
  - drywall, detail model, 456
  - elevator
    - design review, 452f
    - detailed design/coordination, 452–453
  - estimated cost, graph, 470f



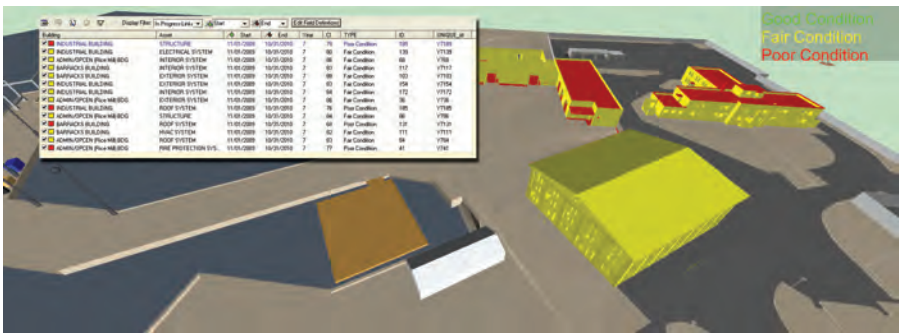
- facility, computer assembly, 440f  
 federated document collaboration  
   system, usage, 458–459  
 Federated Model Management  
   architecture, 460f  
 final structural design model, 450f  
 IFOA, 434–441  
 Integrated Project Delivery  
   (IPD), 435  
   team, members, 436t  
 integrated project team,  
   development, 436f  
 lean design approaches, 437t  
 lessons, 476–479  
 look-ahead network plan, 462f  
 manual estimating process flow, 465f  
 MEP designer/subcontractor,  
   collaboration, 456  
 MEP/FP system model, 451f  
 milestone schedule, 444f  
 model-based cost estimating, 462–475  
   benefits, 473–474  
   implementation, challenges, 473  
   lessons, 474–475  
   necessity, 464–465  
   process, 466f, 469f  
   solutions, 465–467  
 model-based estimating  
   creation, 469–473  
   preparation, 471–473  
 model servers, location, 460f  
 model size issues, 457  
 Navisworks model, combination, 458f  
 object parameters/cost assemblies,  
   matching, 472f  
 opportunity issues, 461–462  
 OSHPD approval milestones, 446  
 OSHPD permit documents, creation,  
   456f  
 OSHPD phased plan review, 442  
 owner goals, 435, 434t  
 owner goods, 432  
 painshare/gainshare plan, 441–442  
 preliminary/detailed design, 442–449  
 problems, 456–457  
 process mapping  
   network, 462f  
   strategic project solutions  
     production manager, usage, 461  
 project description, 432–434  
 project management techniques,  
   description, 434–442  
 project milestones, 433t  
 project team support, technologies  
   (usage), 454–462  
 Revit/Tekla models, interoperability  
   (absence), 457  
 risks  
   avoidance/minimization, 446  
   tracking, 461–462  
 self-perform work, DPR model-  
   based cost estimating solution,  
   468–469  
 software, usage, 438t–439t  
 stairs  
   design/coordination, 453–454  
   model review, 453f  
   subgroup, 443–444  
 sustainability goals, 475–476  
   design/construction modifications,  
   examples, 476t  
 target value design (TVD), 462, 464  
 team collaboration, support  
   decisions, 450–452  
 3D BIM systems, compatibility, 466f  
 web-based virtual participation, 459f  
 workflow (process map), 448f  
 Sweeps, 33f  
 Systems integrator, 259
- T**
- Target value design (TVD), 462, 464  
 Teaming, challenges, 26–27  
 Teamwork, enhancement, 326  
 Technological drivers, 380–382  
 Technology  
   risks, 188–189  
   trends, 352  
 Tekla Structures, 51, 88–91, 102  
   automated reinforcing layout/  
     connections, 51f  
   format support, 90t  
   interface support, 89  
   Lite-wall precast pieces, stack, 225f  
   model/field data, 232f  
   input, 485f  
   Revit model, interoperability  
     (absence), 457  
   strengths, 89, 91  
   structural steel connection, 329f  
   weaknesses, 91  
 Tekla Structures for Construction  
   Management software, 484  
 Texture maps, preapplication, 244  
 Thickness, definition, 42  
 3D-based Internet technologies,  
   availability (increase), 362  
 3D/BIM  
   building model, merge/update, 290  
   usage, 303  
 3D BIM systems, compatibility, 466f  
 3D catalogs, building product  
   manufacturer provision, 359  
 3D details, automatic development  
   (smart routines), 375–376  
 3D sketching tools, 206–222  
 Three-dimensional (3D) CAD, 2  
   tools, implementation, 2  
 Three-dimensional (3D) modeled  
   objects, usage, 32  
 Three-dimensional (3D) modeling, 33–39  
   development, 38  
 Three-dimensional (3D) solid modeling,  
   36–37  
 Tilt-up concrete construction panels,  
   designers, 310  
 Time to market, 165–167  
   reduction, parametric models  
     (usage), 165  
 Tool-level capabilities, 74  
 Top-level drawing functionality,  
   support, 63  
 Topology, 57  
 Toyota Production System (TPS), lean  
   production, 297–298  
 Toyota Way, 387  
 Trade contractors, detail design  
   (prevention), 436–437  
 Trained personnel, absence, 371  
 Training costs, elevation, 186–187  
 Transaction  
   definition, 136–138, 589  
   usage, ease, 138  
 Transformation-Flow-Value (TFV)  
   concept, 298  
 Trelligence, 212–213  
   Affinity, 373  
 Two-dimensional (2D) CAD, 2  
   drawings, 12  
   reference files, combination, 19  
   technology, platform, 321  
 Two-dimensional (2D) drawings,  
   generation, 21–22
- U**
- Undefined, 117  
 Unevaluated shape, 36  
 Uniformat, 130, 236, 253  
 United States Coast Guard (USCG)  
   BIM-based assessment system,  
     small-scale implementation  
     (lessons), 577  
   BIM-based scenario planning system,  
     implementation (lessons),  
     580–581

- United States Coast Guard (USCG)  
(*Continued*)
- BIM implementation, 566
    - Roadmap, 567f
  - building information model, levels, 572f
  - building model data, views  
(OCCSU Planner system usage), 579f
  - case study, 566
  - export utilities, 579
  - facility assessment/planning, BIM  
(usage), 569–577
  - facility assessment Roadmap, 570f
  - facility assessment system
    - description, 571–574
    - requirements, 569–571
  - facility condition index, 569
  - hazardous material data, viewing  
schedule, 575f
  - interoperability goals,
    - implementation, 567f
  - ISC PRoject, planning system  
(usage), 574–576
  - lessons, 583–584
  - Level 2/3 building model, team  
creation, 572–573
  - manual/BIM-based assessment  
processes, comparison, 576f
  - medium-scale implementation, OPS  
involvement, 574
  - mission dependency index, 569
  - OCCSU Planner system,
    - workflow, 578f
  - OCCSU system, 581–583
  - projects, partner service providers,
    - overview, 568t
  - reporting tools, 579
  - rooms
    - assessment values, plan view, 575f
    - information, OPS interfaces, 573f
    - sample, template layout  
(display), 578f
  - SCCP benefits, personnel  
discussion, 581
  - scenario planning, BIM usage,
    - 577–581
  - scenario planning system
    - description, 577–579
    - implementation, 579–580
  - sector command centers design,
    - BIM-based scenario planning  
implementation (metrics), 580t
  - space utilization index, 569
  - 3D room layout, 579
  - 2D room layout, 579
- Unit systems, 338
- U.S. Coast Guard, internal knowledge  
construction, 177
- U.S. Courts Design Guide*, 214, 216
- U.S. Green Building Council, 415–416
- Userdefined, 117
- User-defined parametric objects,
 54–57
- V**
- Value engineering, usage, 2
- Vancouver Convention Center  
construction, 4D view, 283f
- Variation (reduction), BIM (usage), 298
- Vectorworks (Nematschek), 40, 68,
 86–88
  - in-memory system, 87
  - interfaces, 87
- Vendors, BIM scope expansion, 359
- Vertical logic, 246f
- Veterans Administration BIM  
Guide*, 355
- Veterans' hospital, lifetime  
capital/operating costs  
(components), 255f
- Vico Estimator, 277–278
- Virtual BIM, linking (enabling), 360
- Virtual construction, 306
  - concept, 360
- Virtual Design and Construction Survey  
(VDC)*, 360
- Virtual Reality Cave environment, 159f
- Vision 2015, 361–380
  - limitations, 379–380
- Visual Basic scripting language, 209
- Visual inspection, technical  
possibility, 372
- Visualization formats, 384
- Vizella FACILITY space,
  - screenshot, 171f
- Volume-enclosing criteria, 33
- W**
- Wall-object family, conceptual  
structure, 41f
- Walls
  - construction, assignation, 42
  - type, 117
  - ubiquity/complexity, 42–43
- Waste, occurrence, 317
- Web-based project management  
systems, 136
- Web-based virtual participation,
 GoToMeeting (usage), 459
- Webex, 440, 452
- Welding instructions, output, 334
- Wireless Application Protocol  
(WAP), 106
- Within object parametric relations, 64
- Work distribution, increase, 327–328
- Work face, 378–379
- Workflows
  - definition, 589
  - improvement, 100
  - stability (improvement), BIM  
(usage), 326
- Work processes, 376–379
- Y**
- Yas Island Formula One, physical  
spaces, 368f



**FIGURE 4-8**

Images provided courtesy of Legion Limited.

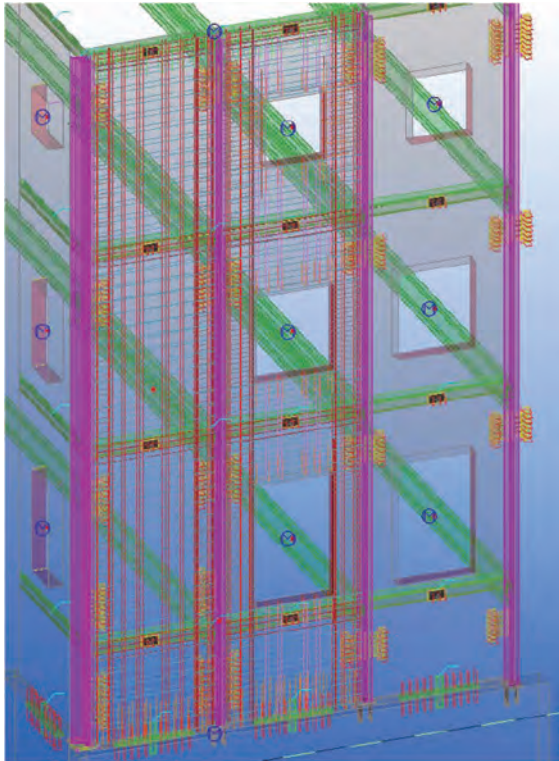


**FIGURE 4-10**

Image provided courtesy of PBS&J, Common Point, Inc., AEC Infosystems, Inc., and MACTEC, Inc.

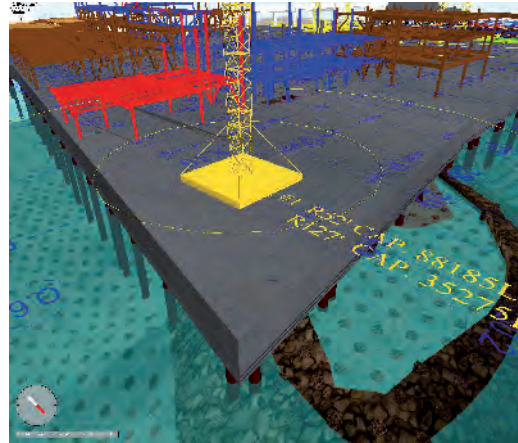
**FIGURE 5-2**

Left image copyright JE Dunn Construction Company. Right image courtesy of Lord Aeck & Sargent Architecture.



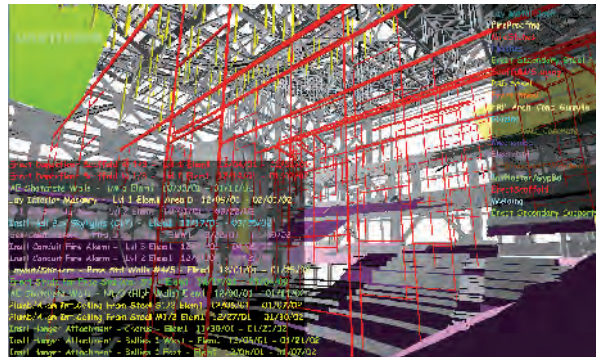
**FIGURE 5-16**

Image provided courtesy of Gregory P. Luth & Associates, Inc.



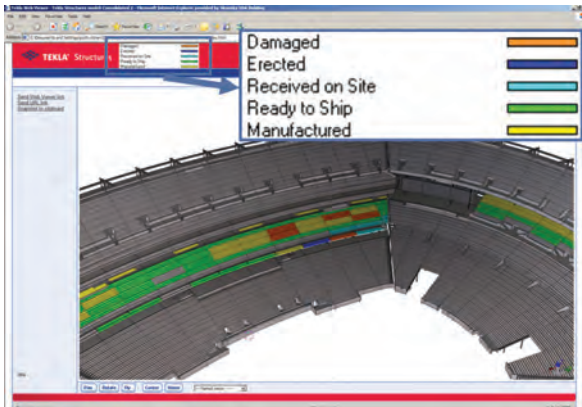
**FIGURE 6-10**

Courtesy Pacific Project Systems Inc., MTC Design/3D, (4D modeling); Musson Cattell Mackey Partnership, Downs/Archambault & Partners, LMN Architects (architects); Glotman Simpson Consulting Engineers (structural engineers); PCL Constructors Westcoast Inc. (CM)



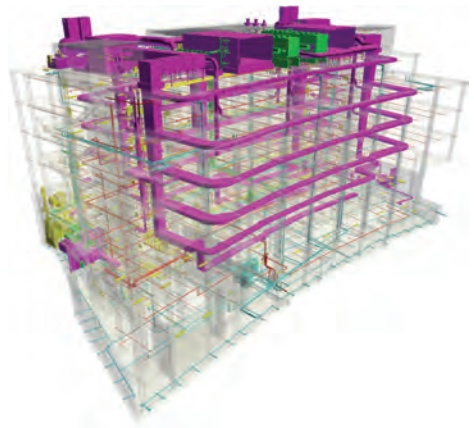
**FIGURE 6-15**

M.A. Mortenson, Inc.



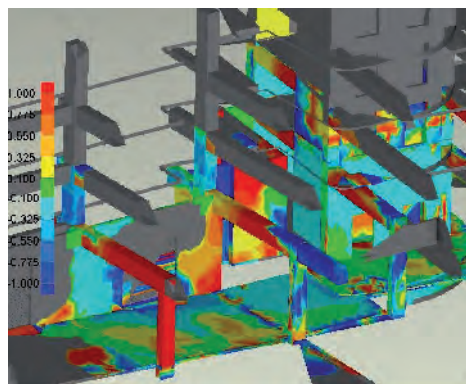
**FIGURE 7-7 (bottom)**

Photos courtesy of Vela Systems, Inc. All rights reserved.



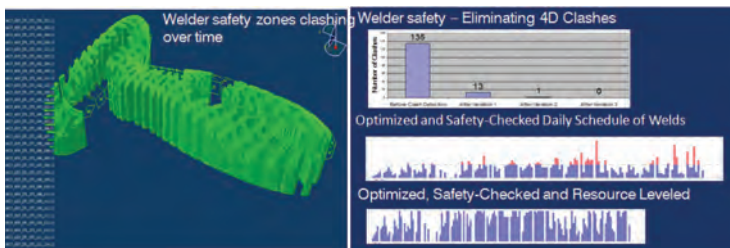
**FIGURE 7-8**

Image courtesy of Mortenson.



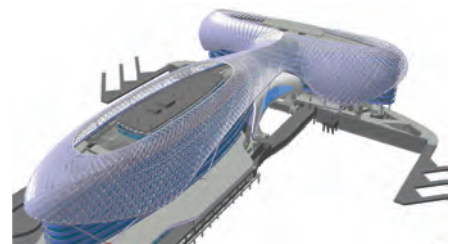
**FIGURE 8-2**

Image courtesy of Elsevier (Akinci et al. 2006).



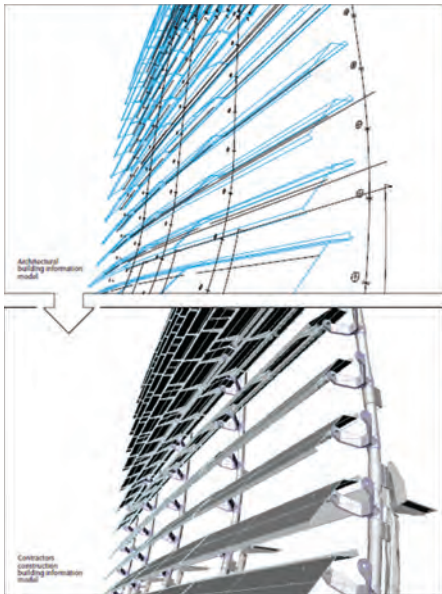
**FIGURE 8-5**

Architect: Asymptote Architecture. Images courtesy Gehry Technologies.





**FIGURE 9-1-2** Photo credit: Chris Gascoigne.



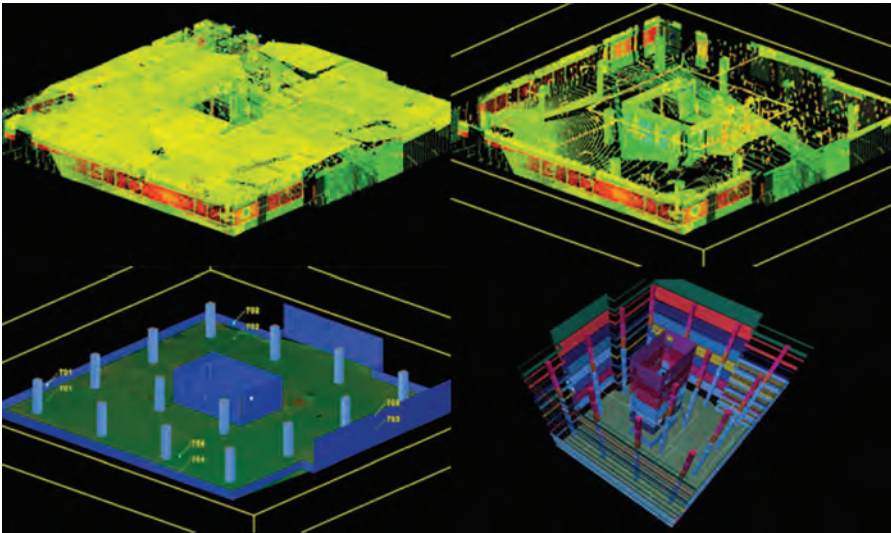
**FIGURE 9-1-8**



**FIGURE 9-1-11**

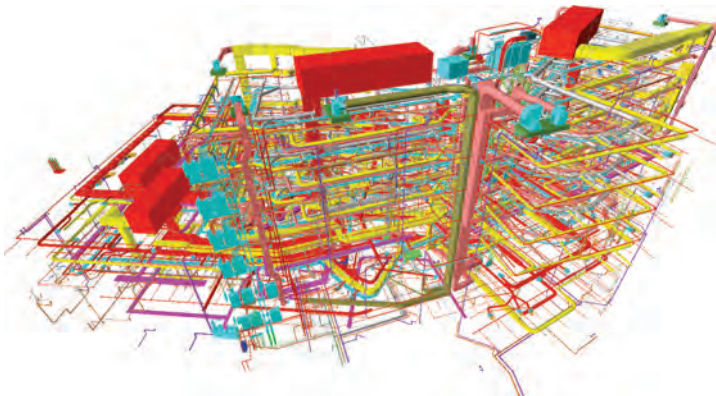


**FIGURE 9-2-3**



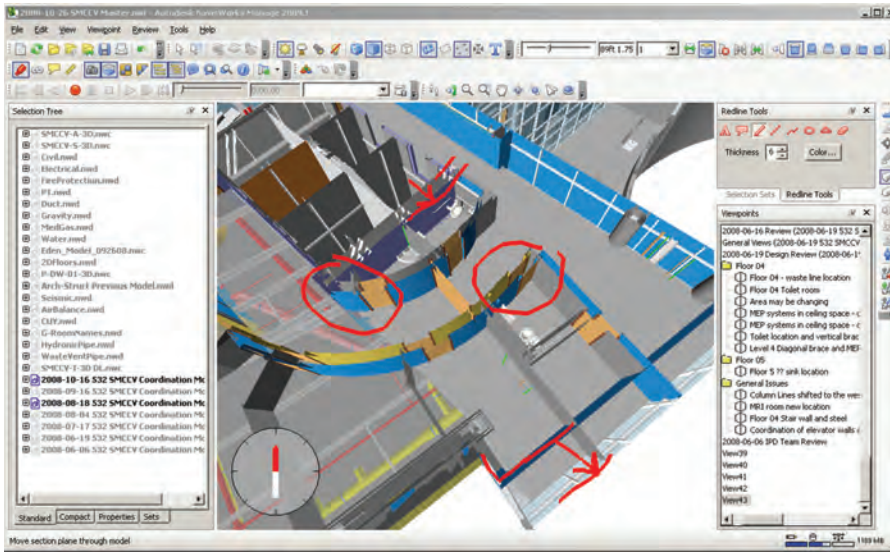
**FIGURE 9-2-6**

Image credit: Hoffman Construction Company.



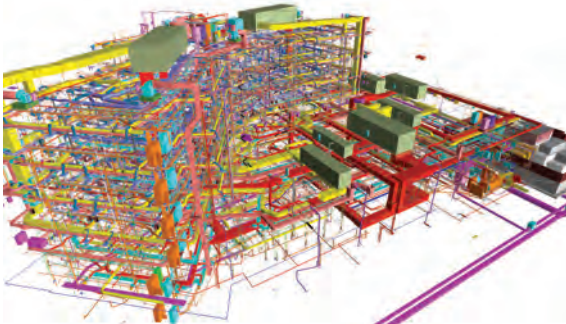
**FIGURE 9-3-12**

Image provided courtesy of Sutter Health.



**FIGURE 9-3-14**

Image provided courtesy of Sutter Health.



**FIGURE 9-3-16**

Image provided courtesy of Sutter Health.

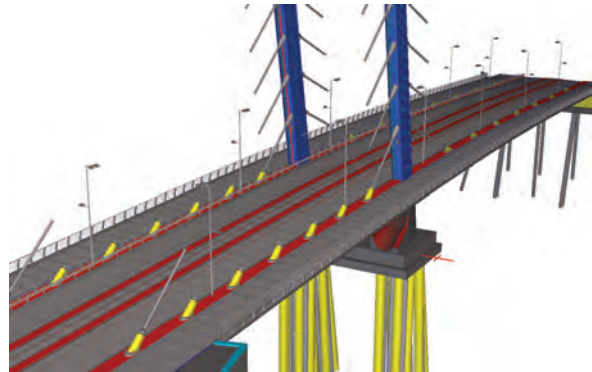


**FIGURE 9-3-17**

Image provided courtesy of Ghafari Associates.



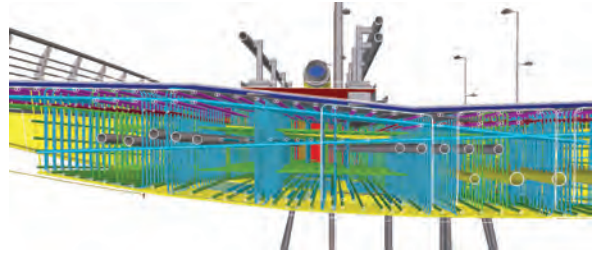
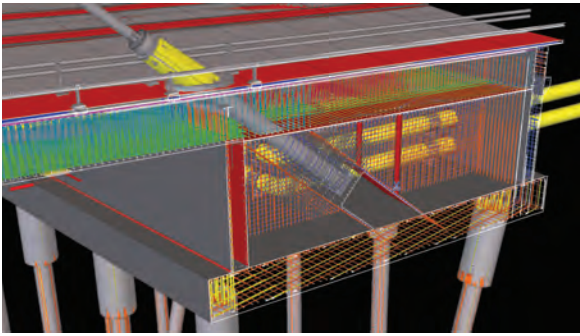
**FIGURE 9-4-5**



**FIGURE 9-5-3**

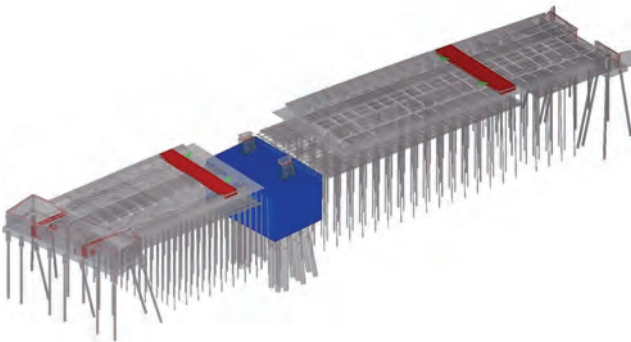
Image courtesy of Skanska Finland.





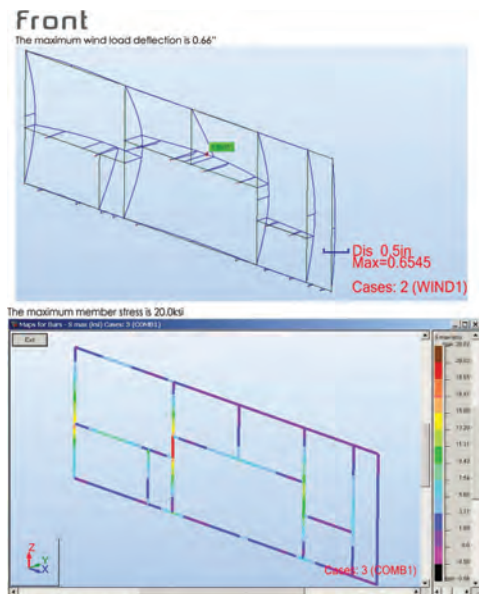
**FIGURE 9-5-7**

Image courtesy of Skanska Finland.



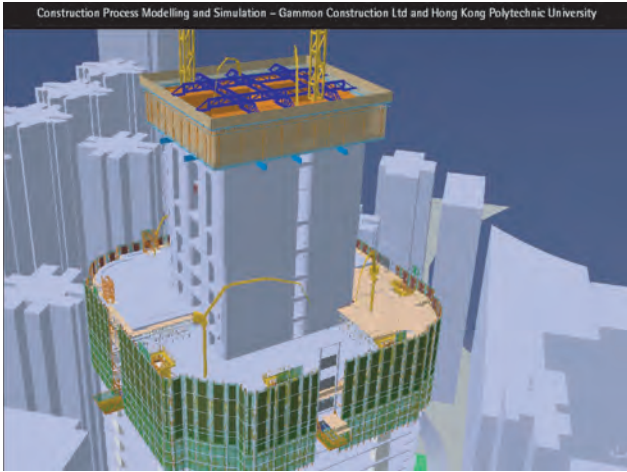
**FIGURE 9-5-9**

Image courtesy of Skanska Finland.



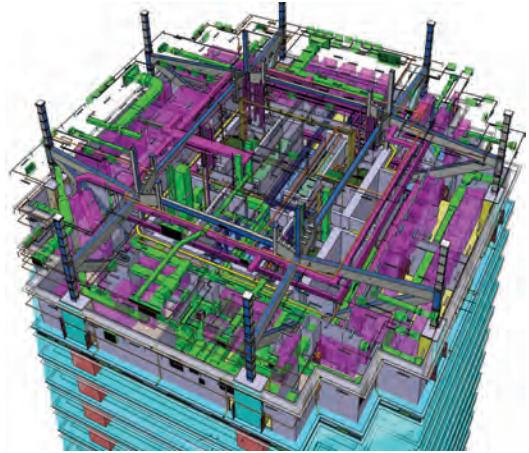
**FIGURE 9-6-8**

Image provided courtesy Ateliers Jean Nouvel and Front Inc.



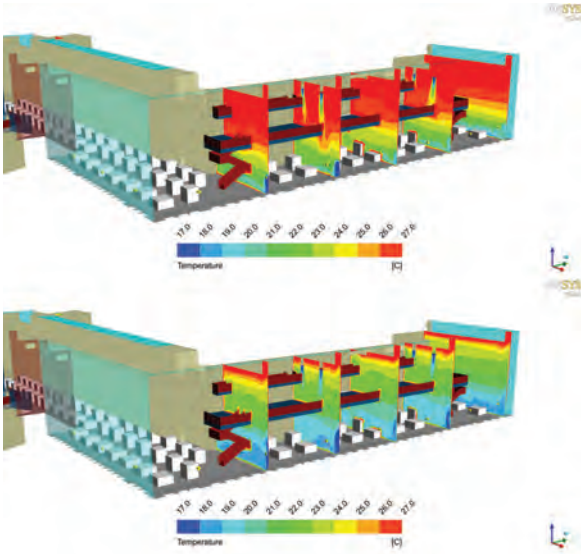
**FIGURE 9-7-10**

Image provided courtesy of Gammon Construction Ltd., and Professor Heng Li at Hong Kong Polytechnic University.

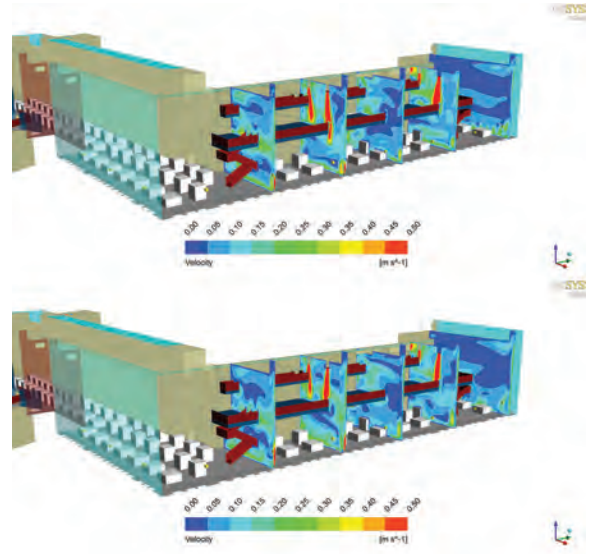


**FIGURE 9-7-12**

Image provided courtesy of Gammon Construction Ltd., and Professor Heng Li at Hong Kong Polytechnic University.



**FIGURE 9-8-10**



**FIGURE 9-8-11**